



User Manual  
SKU: TPX00241



## Description

The Arduino® USB-C Hub (8 in 1) (TPX00241) is a compact multiport adapter designed for use with USB-C devices. This hub expands a single USB-C port into eight functional interfaces, including power delivery, USB data ports, HDMI video output, Ethernet connectivity, and SD/TF card readers. With its plug-and-play design and broad OS compatibility, it provides I/O expansion for development, prototyping, and deployment scenarios.



# CONTENTS

<b>1 Features</b>	<b>3</b>
1.1 General Specifications	3
1.2 Port Configuration	4
1.3 Operating Conditions	5
1.4 Compatibility	5
<b>2 Usage</b>	<b>6</b>
2.1 Key Use Cases	6
<b>3 Technical Specifications</b>	<b>6</b>
3.1 Video Output	6
3.2 Network	7
3.3 Card Readers	7
3.4 Power Delivery	7
<b>4 Mechanical Information</b>	<b>8</b>
4.1 Dimensions	8
4.2 Package Contents	9
<b>5 Certifications</b>	<b>10</b>
5.1 Declaration of Conformity CE DoC (EU)	10
5.2 Declaration of Conformity to EU RoHS & REACH	10
5.3 Conflict Minerals Declaration	11
<b>6 FCC Caution</b>	<b>12</b>
<b>7 Company Information</b>	<b>12</b>
<b>8 Reference Documentation</b>	<b>12</b>
<b>9 Trademark Acknowledgement</b>	<b>12</b>
<b>10 Document Revision History</b>	<b>13</b>

# 1 Features

## 1.1 General Specifications

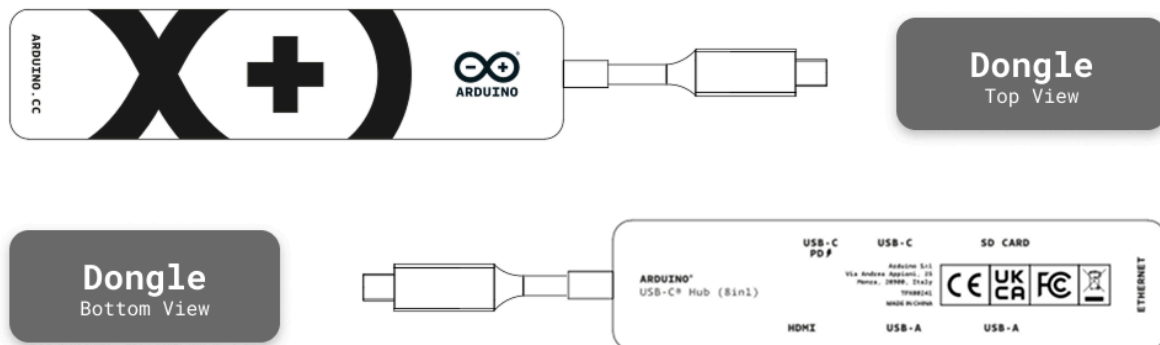

USB-C Hub (8 in 1) Top/Bottom Views

Feature	Specification
Model Number	TPX00241
Color	Black
Cable Length	175 mm
Dimensions	119 × 27.8 × 16 mm
Weight	60 g

## 1.2 Port Configuration

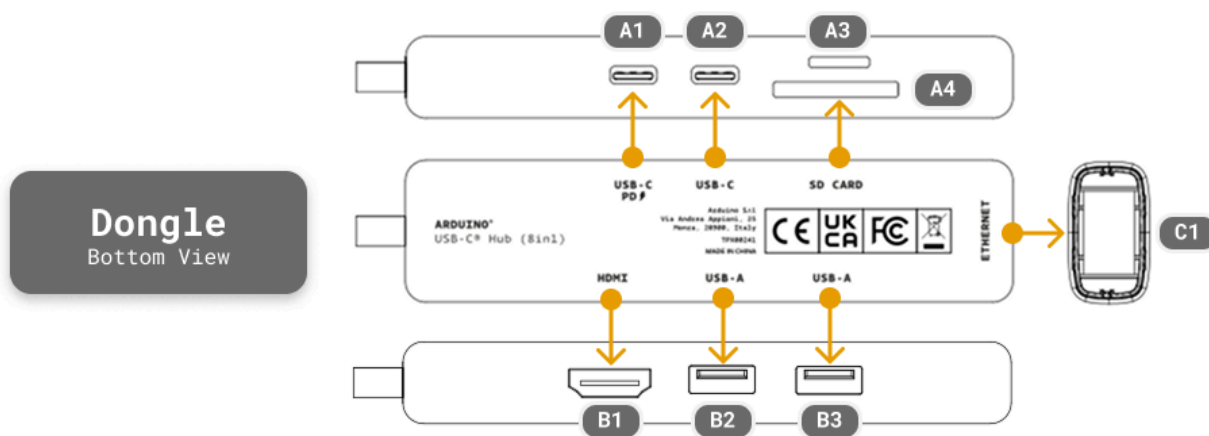

USB-C Hub (8 in 1) Hub Ports

Port Type	Quantity	Specification
USB-C PD (Power) (A1)	1	65 W Power Delivery
USB-C Data (A2)	1	480 Mbps
USB-A 2.0 (B2)	1	480 Mbps
USB-A 3.0 (B3)	1	5 Gbps
HDMI (B1)	1	4K @ 30 Hz (3840 × 2160)
RJ45 Ethernet (C1)	1	100 Mbps
SD Card Reader (A4)	1	USB 2.0, supports SD/SDHC UHS-I-II / SDXC UHS-I-II
TF (microSD) Card Reader (A3)	1	Supports microSD/microSDHC UHS-I / microSDXC UHS-I



### 1.3 Operating Conditions

Parameter	Range
Working Temperature	0 °C – 50 °C
Storage Temperature	-20 °C – 60 °C

### 1.4 Compatibility

System	Version
Windows	XP / 7 / 8 / 10 / 11
macOS	10.2.8 and above
Linux	Supported

**Note:** This Hub is plug-and-play compatible with most operating systems. No additional drivers are required for basic functionality.



## 2 Usage

The USB-C Hub (8 in 1) expands the connectivity of USB-C devices, providing access to external displays, network connectivity, additional USB peripherals, and storage devices. When used with single-board computers in desktop mode, this hub allows connection of multiple peripherals simultaneously.

### 2.1 Key Use Cases

- **Display Output:** Connect HDMI monitors or displays for visual output (up to 4K @ 30 Hz)
- **Network Connectivity:** Wired Ethernet connection via RJ45 port (100 Mbps)
- **USB Peripherals:** Attach keyboards, mice, USB drives, cameras, and other USB devices
- **Storage Expansion:** Read and write SD/TF cards for data logging and file transfer
- **Power Delivery:** Supply power to connected devices while simultaneously using other ports (65 W PD)

**Important:** The hub requires external power delivery through the USB-C PD port. Ensure your power supply provides at least 5 V / 3 A (15 W minimum) for stable operation of connected devices and peripherals. For maximum performance with multiple high-power devices, a 65 W PD charger is recommended.

## 3 Technical Specifications

### 3.1 Video Output

Parameter	Specification
Interface	HDMI Type-A
Maximum Resolution	4K (3840 × 2160) @ 30 Hz
Supported Resolutions	1080p, 720p, 480p
Audio Support	HDMI audio pass-through



### 3.2 Network

Parameter	Specification
Interface	RJ45 Ethernet
Speed	10/100 Mbps (Fast Ethernet)

### 3.3 Card Readers

Parameter	SD Card Reader	TF Card Reader
Interface Speed	USB 2.0 (480 Mbps)	USB 2.0 (480 Mbps)
Supported Cards	SD, SDHC (UHS-I-II), SDXC (UHS-I-II)	microSD, microSDHC (UHS-I), microSDXC (UHS-I)
Maximum Capacity	Up to 2 TB (SDXC)	Up to 2 TB (microSDXC)
LED Indicator	Not available	Not available

**Note:** Both card readers can be used simultaneously. Ensure cards are properly formatted (FAT32, exFAT, or NTFS) for compatibility with your operating system.

### 3.4 Power Delivery

Parameter	Specification
Input Voltage	5 V – 20 V (USB PD standard)
Maximum Power	65 W
Output to Device	Pass-through

The USB-C PD port supports USB Power Delivery negotiation up to 65 W. The actual power delivered to the connected device depends on the power supply capability and the device's power requirements. When multiple peripherals are connected, ensure the power supply can handle the combined load.

## 4 Mechanical Information

### 4.1 Dimensions

The hub features a compact form factor suitable for portable use with various devices. The attached cable provides flexibility for connection without blocking adjacent ports.

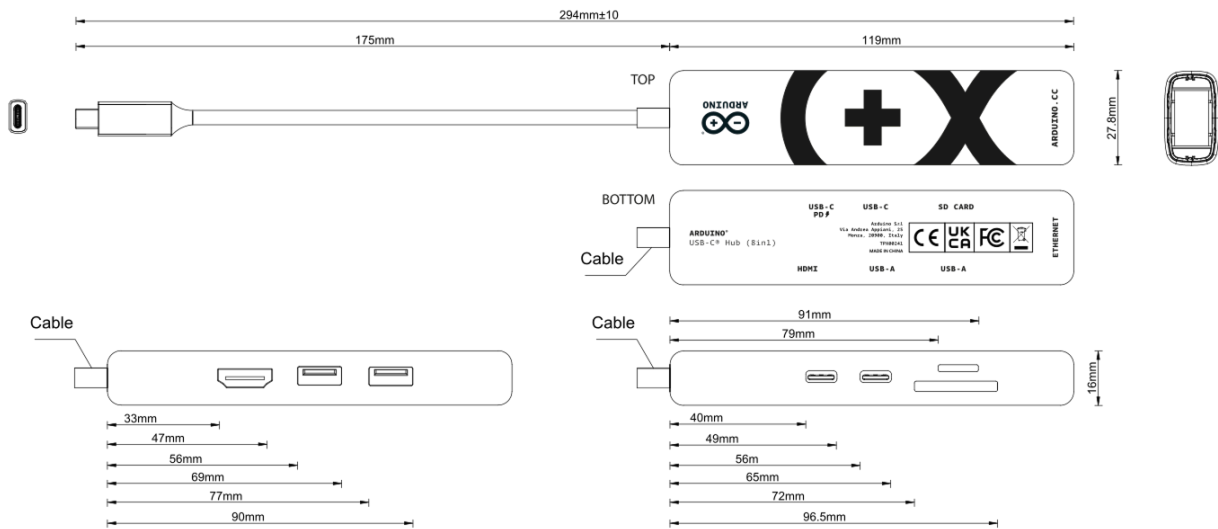

Hub Dimensions

Dimension	Measurement
Length	119 mm
Width	27.8 mm
Height	16 mm
Cable Length	175 mm
Weight	60 g



## 4.2 Package Contents

- 1× Arduino® USB-C Hub (8 in 1)

## 5 Certifications

### 5.1 Declaration of Conformity CE DoC (EU)

English: We declare under our sole responsibility that the products above are in conformity with the essential requirements of the following EU Directives and therefore qualify for free movement within markets comprising the European Union (EU) and European Economic Area (EEA).

French: Nous déclarons sous notre seule responsabilité que les produits indiqués ci-dessus sont conformes aux exigences essentielles des directives de l'Union européenne mentionnées ci-après, et qu'ils remplissent à ce titre les conditions permettant la libre circulation sur les marchés de l'Union européenne (UE) et de l'Espace économique européen (EEE).

### 5.2 Declaration of Conformity to EU RoHS & REACH

Arduino boards and accessories are in compliance with Directive 2011/65/EU of the European Parliament and Directive 2015/863/EU of the Council of 4 June 2015 on the restriction of the use of certain hazardous substances in electrical and electronic equipment.

Substance	Maximum Limit (ppm)
Lead (Pb)	1000
Cadmium (Cd)	100
Mercury (Hg)	1000
Hexavalent Chromium (Cr6+)	1000
Poly Brominated Biphenyls (PBB)	1000
Poly Brominated Diphenyl ethers (PBDE)	1000
Bis(2-Ethylhexyl) phthalate (DEHP)	1000
Benzyl butyl phthalate (BBP)	1000
Dibutyl phthalate (DBP)	1000
Diisobutyl phthalate (DIBP)	1000

Exemptions: No exemptions are claimed.

Arduino products are fully compliant with the related requirements of European Union Regulation (EC) 1907/2006 concerning the Registration, Evaluation, Authorization and Restriction of Chemicals (REACH). We declare none of the SVHCs (<https://echa.europa.eu/web/guest/candidate-list-table>), the Candidate List of Substances of Very High Concern for authorization currently released by ECHA, is present in all products (and also package) in quantities totaling in a concentration equal or above 0.1%. To the best of our knowledge, we also declare that our products do not contain any of the substances listed on the "Authorization List" (Annex XIV of the REACH regulations) and Substances of Very High Concern (SVHC) in any significant amounts as specified by the Annex XVII of Candidate list published by ECHA (European Chemical Agency) 1907/2006/EC.



### 5.3 Conflict Minerals Declaration

As a global supplier of electronic and electrical components, Arduino is aware of our obligations with regards to laws and regulations regarding Conflict Minerals, specifically the Dodd-Frank Wall Street Reform and Consumer Protection Act, Section 1502. Arduino does not directly source or process conflict minerals such as Tin, Tantalum, Tungsten, or Gold. Conflict minerals are contained in our products in the form of solder, or as a component in metal alloys. As part of our reasonable due diligence Arduino has contacted component suppliers within our supply chain to verify their continued compliance with the regulations. Based on the information received thus far we declare that our products contain Conflict Minerals sourced from conflict-free areas.



## 6 FCC Caution

Any Changes or modifications not expressly approved by the party responsible for compliance could void the user's authority to operate the equipment.

This device complies with part 15 of the FCC Rules. Operation is subject to the following two conditions:

- (1) This device may not cause harmful interference
- (2) this device must accept any interference received, including interference that may cause undesired operation.

### FCC RF Radiation Exposure Statement:

This equipment complies with FCC radiation exposure limits set forth for an uncontrolled environment.

## 7 Company Information

Company name	Arduino S.r.l.
Company address	Via Andrea Appiani 25, 20900 Monza (Italy)

## 8 Reference Documentation

No.	Reference	Link
1	Arduino Store	<a href="https://store.arduino.cc/">https://store.arduino.cc/</a>

## 9 Trademark Acknowledgement

The terms HDMI, HDMI High-Definition Multimedia Interface, HDMI trade dress and the HDMI Logos are trademarks or registered trademarks of HDMI Licensing Administrator, Inc.



## 10 Document Revision History

Date	Revision	Changes
07/04/2026	2	Added HDMI trademark acknowledgement
27/03/2026	1	First release