

3mm Advanced Super Flux LEDs

34-01/T4C-4PRB/EU

Lead (Pb) Free Product - RoHS Compliant



Features

- High Total Flux Output..
- Designed for High Current Operation.
- Low Thermal Resistance.
- Low Profile.
- Low Power Consumption
- The phosphor filled in the reflector converts the blue emission of InGaN chip to ideal white.
- Typical chromaticity coordinates $x=0.30$, $y=0.29$ according to CIE1931
- The product itself will remain within RoHS compliant version.
- ESD-withstand voltage: up to 2KV
- Compliance Halogen Free .(Br <900 ppm ,Cl <900 ppm , Br+Cl < 1500 ppm)

Applications

- Automotive Lighting
- Electronic Signs and Signals
- Special Lighting application

Device Selection Guide

LED Part No.	Chip		Resin Color
	Material	Emitted Color	
34-01/T4C-4PRB/EU	InGaN	White	Water Clear

Table of Content	Page
Product Nomenclature	2
Absolute Maximum Ratings (Ta=25°C)	3
Electro-Optical Characteristics (Ta=25°C)	4
Color Ranks (IF=30mA , Ta=25°C)	5
Typical Electro-Optical Characteristics Curves	6
Package Dimensions	7
Inner and Outer Label Explanation	8
Antistatic Packing Materials Tube and Standard Boxes	9
Precautions for use	10~12
DISCLAIMER	12
Revision History	13

Product Nomenclature

34	-	01	-	T	4	C	-	4	PR	B	EU
1		2		3	4	5		6	7	8	9

The product name is designated as below:

1.	Product type
2.	Lead-frame type
3.	Emission Color
4.	Chip code
5.	Resin color
6.	Dominant Wavelength Groups & CIE Bin Grading
7.	Power & Luminous Intensity
8.	Range of Forward Voltage specification
9.	Sale place

Absolute Maximum Ratings (Ta=25°C)

Parameter	Symbol	Rating	Unit
Reverse Voltage	VR	5	V
Continuous Forward Current	IF	30	mA
Peak Forward Current (Duty 1/10 @1KHz)	IFP	100	mA
Power Dissipation	Pd	120	mW
LED Junction Temperature	Tj	120	°C
Operating Temperature	Topr	-40 ~ +85	°C
Thermal Resistance	Rth J-A	150	K/W
Storage Temperature	Tstg	-40 ~ +100	°C
Electrostatic Discharge	ESDHBM	2000	V
	ESDMM	200	V
Soldering Temperature (T=5 sec)	Tsol	Wave Soldering : 260 °C for 5 sec. Hand Soldering : 300 °C for 3 sec.	

Electro-Optical Characteristics (Ta=25°C)

Parameter	Symbol	Min.	Typ.	Max.	Condition	Unit
Forward Voltage	V _F	2.8	----	3.8	I _F =30mA	V
Reverse Current	I _R	----	----	10	V _R =5V	uA
Luminous Intensity	Φ _v	3600	5000	7150	I _F =30mA	Mlm
Viewing Angle	2θ 1/2	----	65	----	I _F =30mA	deg
Chromaticity Coordinates	x	----	0.30	----	I _F =30mA	----
	y	----	0.29	----		----
Zener Reverse Voltage	V _Z	5.2	----	----	I _Z =5mA	V

Rank

34-01/T4C-4PRB(EU)

(1)

(2)

(3)

(1) V _F (V)			(2) Color			(3) Φ _v (mlm)		
Bin.	Min.	Max.	Bin.	Min.	Max.	Bin.	Min.	Max.
0	2.80	3.00	A0	----	----	Q	3600	4500
1	3.00	3.20	B5	----	----	R	4500	5650
2	3.20	3.40	B6	----	----	S	5650	7150
3	3.40	3.60						
4	3.60	3.80						

Note:

- 1.Measurement Uncertainty of Forward Voltage : ±0.1V
- 2.Measurement Uncertainty of Total Flux : ±15%

CIE Chromaticity Diagram

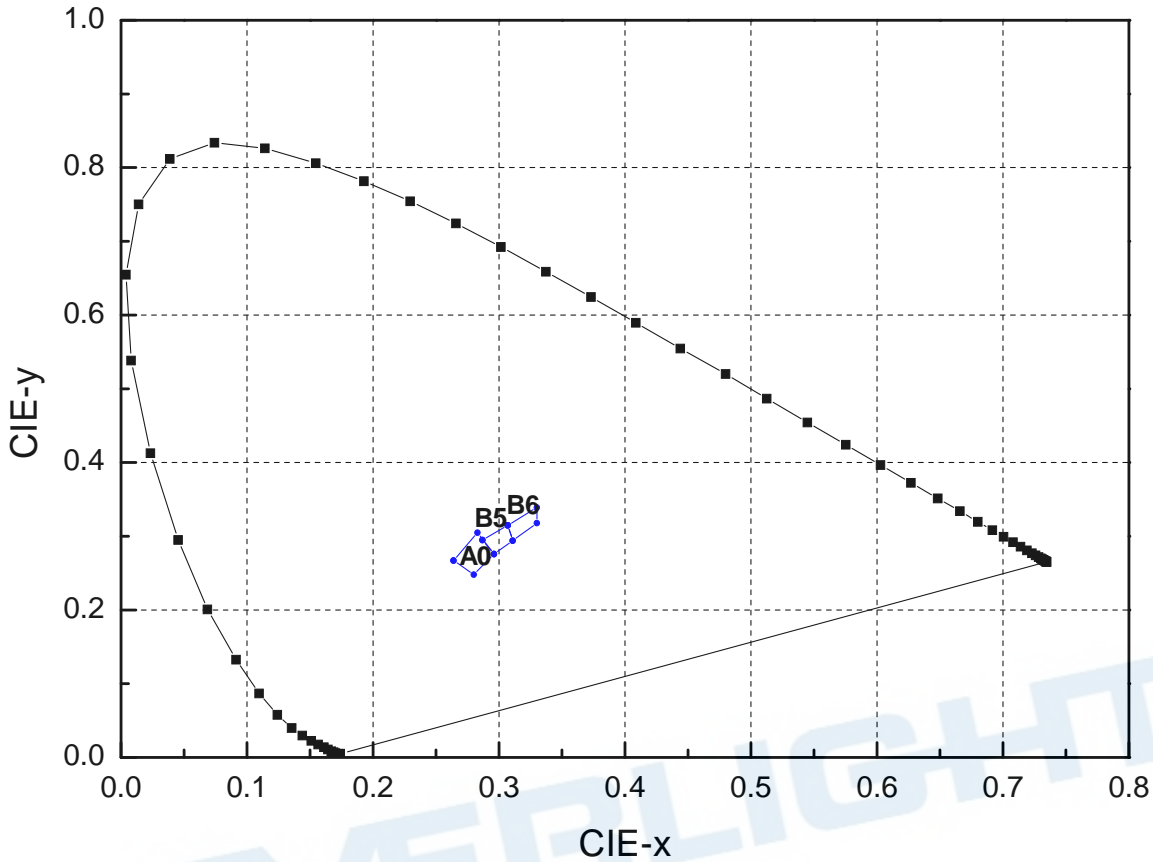

Color Ranks (IF=30mA , Ta=25°C)

Color Ranks		CIE Rank			
A0	X	0.280	0.264	0.283	0.296
	Y	0.248	0.267	0.305	0.276
B5	X	0.296	0.287	0.307	0.311
	Y	0.276	0.295	0.315	0.294
B6	X	0.311	0.307	0.330	0.330
	Y	0.294	0.315	0.339	0.318

*Measurement uncertainty of the color coordinates : ±0.01

Typical Electro-Optical Characteristics Curves

Relative Intensity vs. Wavelength

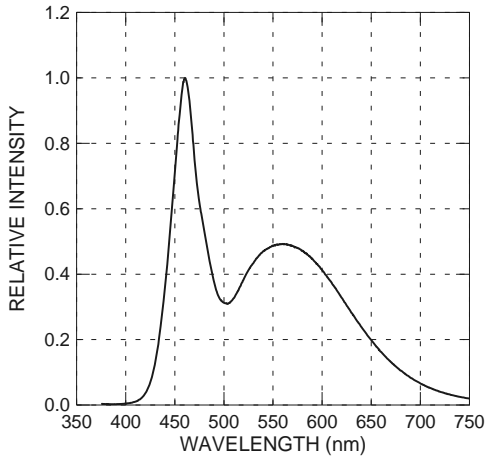

Forward Current vs. Forward Voltage

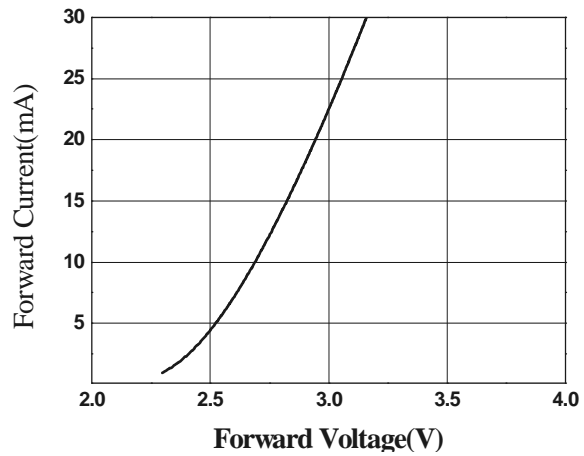

Relative Intensity vs. Forward Current

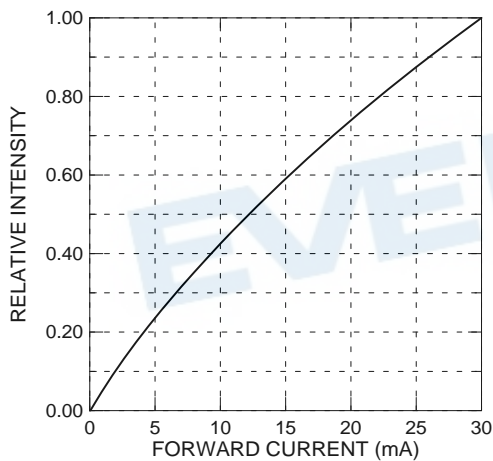

Forward Current vs. Ambient Temp.

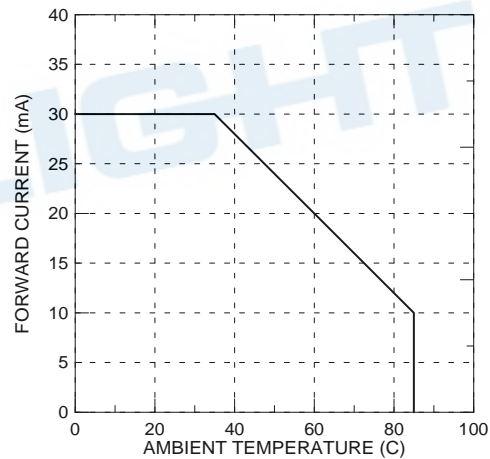

Chromaticity Coordinate vs. Forward Current

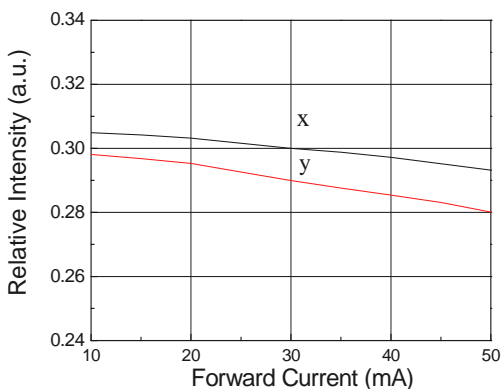

Radiation Characteristics

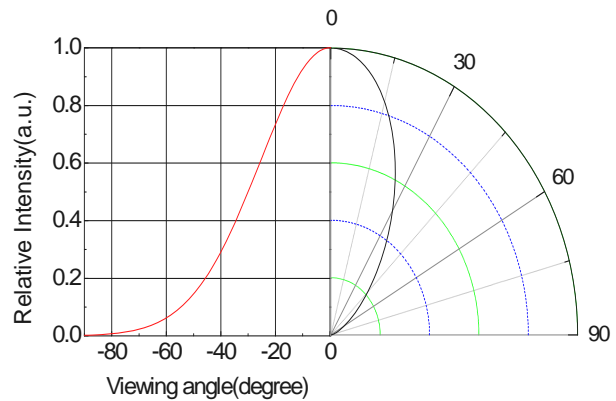

Package Dimensions

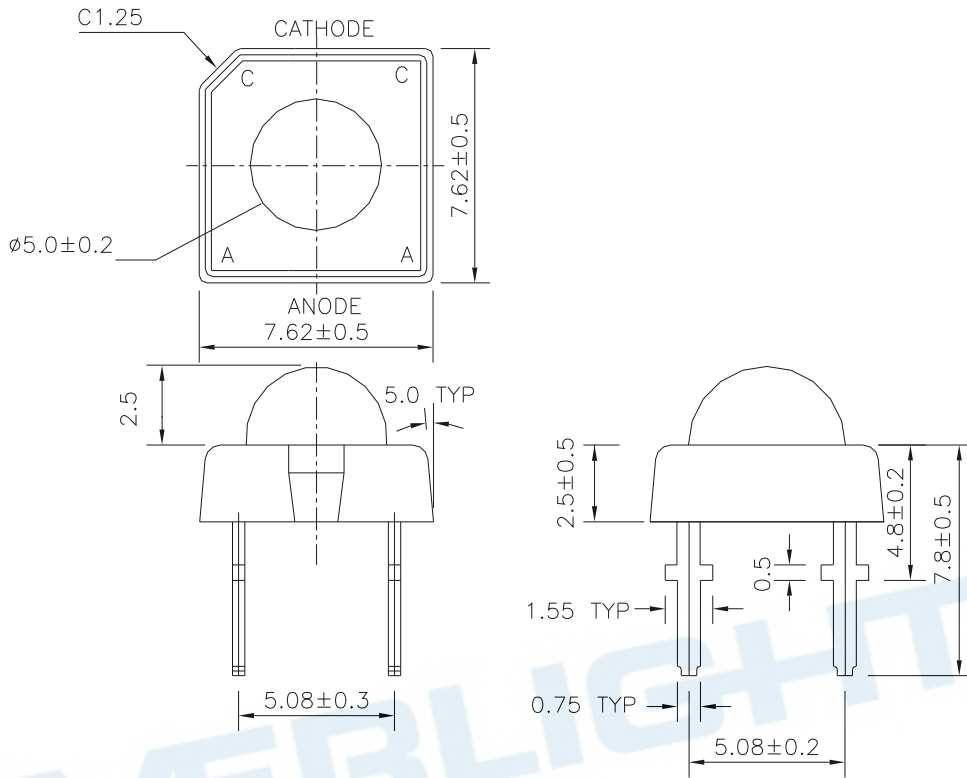

Note:

- 1. An epoxy meniscus may extend about 1.5mm(0.059") down the leads
- 2. Tolerances unless dimensions ± 0.25 mm
- 3. All dimensions are in millimeters

Inner and Outer Label Explanation

Outer Label Explanation

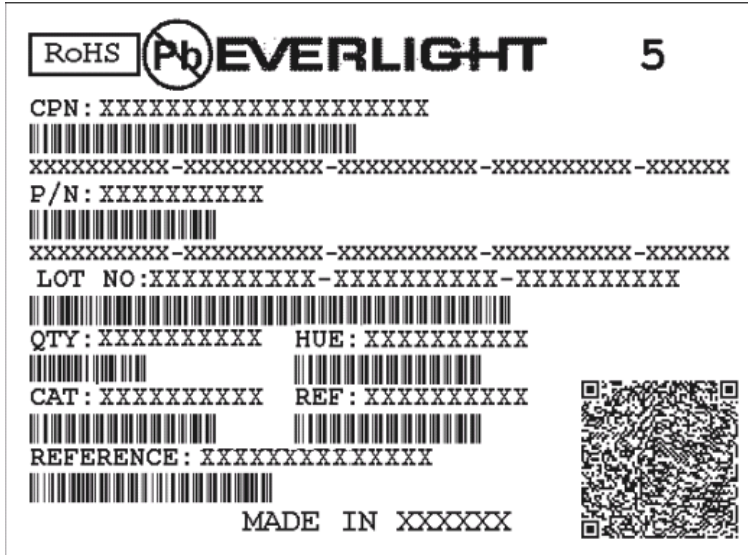

- CPN: Customer's Product Number
- P/N: Product Number
- QTY: Packing Quantity
- CAT: Rank of (VF)(Note*)(ΦV)
- NOTE: λd/CIE/Color temperature
- HUE/REF: Reference
- LOT No: Lot Number
- MADE IN TAIWAN: Production Place

Inner Label Explanation



- P/N: Product Number
- QTY: Packing Quantity
- CAT: Rank of (VF)(Note*)(ΦV)
- NOTE: λd/CIE/Color temperature
- LOT No: Lot Number



Antistatic Packing Materials Tube Materials Tube

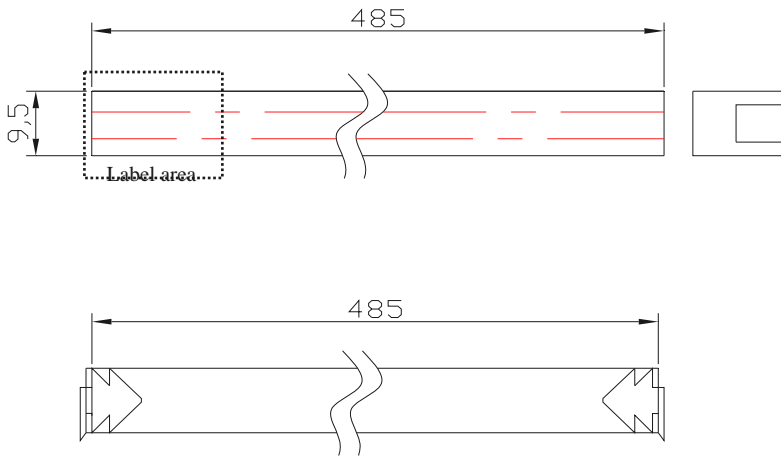

Note:

1. Tolerances unless mentioned $\pm 2.0\text{mm}$.
2. Unit = mm

Standard Boxes

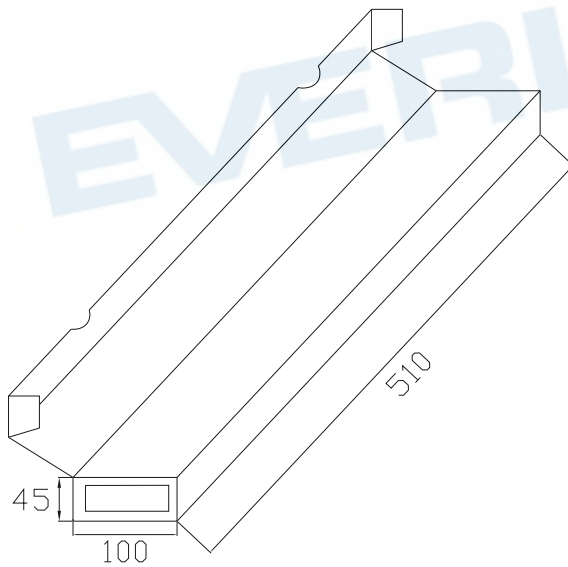

Note:

1. Tolerances unless mentioned $\pm 3.0\text{mm}$.
2. Unit = mm

Precautions for use

1. Lead Forming

- During lead formation, the leads should be bent at a point at least 3mm from the base of the epoxy bulb.
- Lead forming should be done before soldering.
- Avoid stressing the LED package during leads forming. The stress to the base may damage the LED's characteristics or it may break the LEDs.
- Cut the LED leadframes at room temperature. Cutting the leadframes at high temperatures may cause failure of the LEDs.
- When mounting the LEDs onto a PCB, the PCB holes must be aligned exactly with the lead position of the LED. If the LEDs are mounted with stress at the leads, it causes deterioration of the epoxy resin and this will degrade the LEDs.

2. Storage

- The LEDs should be stored at 30°C or less and 60%RH or less after being shipped from Everlight and the storage life limits are 3 months. If the LEDs are stored for 3 months or more, they can be stored for a year in a sealed container with a nitrogen atmosphere and moisture absorbent material.
- Please avoid rapid transitions in ambient temperature, especially, in high humidity environments where condensation can occur.

3. Soldering

- Careful attention should be paid during soldering. Solder the LED no lower than 1.6mm from the base of stopper is recommended.
- Avoiding applying any stress to the lead frame while the LEDs are at high temperature particularly when soldering.
- Recommended soldering conditions:

Hand Soldering		DIP Soldering	
Temp. at tip of iron	300°C Max. (30W Max.)	Preheat temp.	100°C Max. (60 sec Max.)
Soldering time	3 sec Max.	Bath temp.	260 Max.
Distance	No lower than 1.6mm from the base of stopper	Bath time.	5 sec Max.
		Distance	No lower than 1.6mm from the base of stopper

- Recommended soldering profile

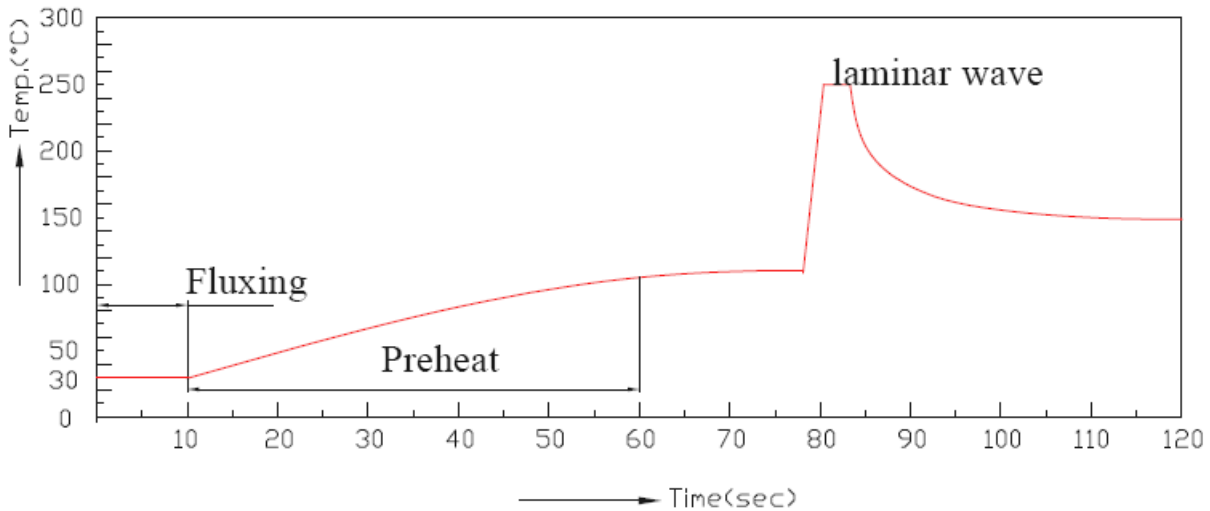

- To avoid any stress to the lead frame while the LEDs are at high temperature particularly when soldering.
- Dip or hand soldering should not be done more than one time.
- The len of LEDs should be protected from mechanical shock or vibration until return to room temperature after soldering.
- Cooling rapidly is not recommended after cold down from peak temperature.
- Dipping parameters must be set and maintain according to recommended range.

4. Cleaning

- Cleaning with isopropyl alcohol should not more than one minute and dry it in room temperature.
- Ultrasonic cleaning is prohibited which may damage the LEDs.

5. Thermal Management

Sufficient thermal management must be implemented. Otherwise, the junction temperature of the die might be over the limit at high current driving condition and LEDs' lifetime might be decreases dramatically.

6. ESD (Electrostatic Discharge)

- The products are sensitive to static electricity or surge voltage. ESD can damage a die and its reliability.

When handling the products, the following measures against electrostatic discharge are strongly recommended:

Eliminating the charge

Grounded wrist strap, ESD footwear, clothes, and floors

Grounded workstation equipment and tools

ESD table/shelf mat made of conductive materials

- Proper grounding is required for all devices, equipment, and machinery used in product assembly.

Surge protection should be considered when designing of commercial products.

- If tools or equipment contain insulating materials such as glass or plastic,

the following measures against electrostatic discharge are strongly recommended:

Dissipating static charge with conductive materials

Preventing charge generation with moisture

Neutralizing the charge with ionizers

7. Directions for use

The LEDs should be operated with forward bias. The driving circuit must be designed so that the LEDs are not subjected to forward or reverse voltage while it is off. If reverse voltage is continuously applied to the LEDs, it may cause migration resulting in LED damage.

8. Other

- EVERLIGHT assumes no responsibility for any damage resulting from use of the product which does not comply with the absolute maximum ratings and the instructions included in these specification sheets.
- These specification sheets include all the contents are protected under copyright of EVERLIGHT Corporation. Please don't reproduce or cause anyone to reproduce without EVERLIGHT's permission.

Application Restrictions

High reliability applications such as military/aerospace, automotive safety/security systems, and medical equipment may require different product. If you have any concerns, please contact Everlight before using this product in your application. This specification guarantees the quality and performance of the product as an individual component. Do not use this product beyond the specification described in this document.

DISCLAIMER

1. EVERLIGHT reserves the right(s) on the adjustment of product material mix for the specification.
2. The product meets EVERLIGHT published specification for a period of twelve (12) months from date of shipment.
3. The graphs shown in this datasheet are representing typical data only and do not show guaranteed values.
4. When using this product, please observe the absolute maximum ratings and the instructions for using outlined in these specification sheets. EVERLIGHT assumes no responsibility for any damage resulting from the use of the product which does not comply with the absolute maximum ratings and the instructions included in these specification sheets.
5. These specification sheets include materials protected under copyright of EVERLIGHT. Reproduction in any form is prohibited without obtaining EVERLIGHT's prior consent.
6. This product is not intended to be used for military, aircraft, medical, life sustaining or life saving applications or any other application which can result in human injury or death. Please contact authorized Everlight sales agent for special application request.

Revision History

Rev.	Modified date	File modified contents
1	2016-8-24	New Spec.
2	2016-9-8	Version change
3	2023/9/13	SIX additional statements

EVERLIGHT