

億力光電股份有限公司

EVERVISION ELECTRONICS CO., LTD.

Product Specification For LCD Module

(KVPF-7B-002-16)

Model NO. : VGG804849-6UFLWH(RoHS)

REVISION : 2

APPROVAL FOR SPECIFICATIONS ONLY





APPROVAL FOR SPECIFICATIONS AND SAMPLE

CUSTOMER :

STD.

APPROVED BY :

EVERVISION LCM R&D CENTER

APPROVED BY	CHECKED BY	PREPARED BY	
	 		
DIRECTOR	MANAGER	Mechanism Engineer	Electronic Engineer

億力光電股份有限公司總公司
EVERVISION ELECTRONICS CO., LTD.
新北市中和區建一路 186 號 6 樓
6F., No.186, Jian 1st Rd., Zhonghe Dist.,
New Taipei City 235, Taiwan
TEL : +886 2 8227-2788
FAX : +886 2 8227-2799

億力光電股份有限公司台中分公司
EVERVISION ELECTRONICS CO., LTD.
-Taichung Branch
台中市潭子區建國路 19 號
No.19, Jianguo Rd., Tanzi Dist.,
Taichung City 427, Taiwan
TEL : +886 4 2532-8889
FAX : +886 4 2532-6689

勁佳光電(昆山)有限公司
VBEST ELECTRONICS(KUNSHAN) Co., Ltd.
江蘇省昆山市玉山鎮高科技工業園城北路 8 號
No.8, Chengbei Rd., Hi-Tech Industry Park,
Yushan Town, Kunshan City, Jiangsu, China.
TEL : +86 512 5778 7288
FAX : +86 512 5777 0688

勁佳光電(昆山)有限公司東莞分公司
VBEST ELECTRONICS(KUNSHAN)Co.,Ltd.
- DongGuan Branch
東莞市莞城區東縱大道天寶路 23 號
No.23 Tian Bao Rd., Dong Zong St.,
Dong Guan City, Guang Dong, China.
TEL : +86 769 3887 5000
FAX : +86 769 3896 0580

<http://www.evervisionlcd.com>

EVERVISION	MODEL NO.		PAGE
	VGG804849-6UFLWH	SPEC SAMPLE	2

1. Table of Contents

No.	Contents	Page
1	Table of Contents	2
2	Record of Revisions	3
3	Module Numbering System	4
4	Application	5
5	Features	5
6	General Specifications	5
7	Absolute Maximum Ratings	6
8	Electrical Characteristics	7
9	Block Diagram	9
10	Input / Output Terminals Pin Assignment	10
11	Interface Timing	14
12	Optical Characteristics	17
13	Reliability Test	20
14	Packaging	21
15	Precautions	22
16	Outline Drawing	26
17	Definition of Labels	27
18	Incoming Inspection Standards	29

3. Module Numbering System

V G G 8048 49 – 6 U F L W H

Serial No:A~Z

Backlight Color:
N:Without Backlight;
A:Amber; **B:**Blue; **G:**Green;
L:Yellow; **O:**Orange; **R:**Red;
W:White; **Y:**YellowGreen;
X:Others

Backlight Type:
N:Without Backlight; **E:**EL; **F:**CCFL;
L:General LED; **H:**High NTSC LED ;
R:RGB LED; **X:**Others

LCD Model:
A:ASTN; **B:**STN Blue; **C:**CSTN; **D:**DSTN;
E:MSLC; **F:**TFT; **G:**STN Gray;
H:HTN ; **I:**IBN; **K:**Black Mask TN; **L:**LTPS; **M:**MVA;
N:Others; **O:**OLED; **P:**PLED; **S:**IPS;
T:TN; **U:**FSC TN; **W:**FSTN Black/White;
X:FFSTN; **Y:**STN Yellow

LCD Type:
R: Reflective/Positive;
S : Reflective/Negative ;
F : Transflective/Positive ;
G: Transflective/Negative ;
U: Transmissive/Positive ;
T: Transmissive/Negative ; **N:**Others

Temperature Range & View Direction:
 General Purpose : **1:**6H **2:**12H **3:**3H **4:**9H **5:**Others
 High Performance: **6:**6H **7:**12H **8:**3H **9:**9H **0:**Others

STD Product Serial No.: 01~99
 Customer Made Serial No.: A1,A2...A9,B1,B2...B9,C1..

Display Function:
 Segment Number / Characters Lines / Column and Row Dots
 / Length * Width of Other

Display Type:
C:Character Type; **G:**Graphic Type; **S:**Segment Type; **O:**Other

LCM Type:
B:COB; **F:**COF; **G:**COG; **H:**Heat Seal; **K:**Touch Key ; **S:**SMT; **T:**TAB; **O:**Others;

4. Application

This specification is applied to the 7 inch WVGA supported TFT-LCD module, and can display true 262,144 colors(6 bit/ color). This module is composed of a 7" TFT-LCD panel, a driver circuit and backlight unit and used as the input devices for general electric appliances via both finger and pen-entry.

5. Features

- WVGA (800×480 pixels) resolution.
- Digital 18 bit parallel RGB.
- Transparent Touch panel
 - 4-Wire
 - Analog Resistive

6. General Specifications

Item	Specifications	Unit
Screen Size	7 (Diagonal)	inch
Display Format	800RGB(H)×480(V)	dot
Active Area	152.40(H)×91.44(V)	mm
Pixel Pitch	0.1905(H)×0.1905(V)	mm
Pixel Configuration	RGB Vertical Stripe	-
Display Mode	TN Type / Transmissive Mode / Normally White	-
Surface Treatment	Anti-Glare and Hard Coating(3H)	-
Viewing Direction	6 O'clock (The Gray Inversion will appear at this direction)	-
Outline Dimension	166.6(W)×109.4(H)×11.5(D)	mm
Weight	(214)	g
RoHS Compliance	RoHS Compliance	-

7. Absolute Maximum Ratings

7.1 Absolute Ratings of Environment

Item	Symbol	Value		Unit	Note
		Min.	Max.		
Storage Temperature	T _{ST}	-30	+80	°C	(1)(2)
Operating Temperature	T _{OP}	-20	+70	°C	(1)(2)

Note1: Background color changes slightly depending on ambient temperature.

This phenomenon is reversible.

Note2: Please refer to item of RELIABILITY.

7.2 Electrical Absolute Ratings

7.2.1 TFT-LCD Module

(Ta=25±2°C, GND=V_{SS}=0V)

Item	Symbol	Value		Unit	Note
		Min.	Max.		
Digital Power Supply Voltage	VCC	-0.3	5.0	V	-

7.2.2 Backlight Unit

(Ta=25±2°C)

Item	Symbol	Value		Unit	Note
		Min.	Max.		
Forward Current of Backlight Unit	IB	-	455	mA	(1)
Reverse Voltage of Backlight Unit	VR	-	3.6	V	(1)

Note (1) Permanent damage to the device may occur if maximum values are exceeded or reverse voltage is loaded.

8. Electrical Characteristics

8.1 TFT-LCD Module

(Ta=25±2°C)

Item	Symbol	Value			Unit	Note
		Min.	Typ.	Max.		
Power Supply Voltage	VCC	3.0	3.3	3.6	V	-
Power Supply Current	ICC	-	105	147	mA	(1)
High level input voltage	V _{IH}	0.7VCC	-	VCC	V	-
Low level input voltage	V _{IL}	VSS	-	0.3VCC	V	-
VSYNC Frequency	FV	-	60	-	Hz	-

Note (1) The specified power consumption is under the conditions at VCC=3.3V, F_V=60Hz, whereas a power dissipation check pattern below is displayed.

Black Pattern / 0 Gray

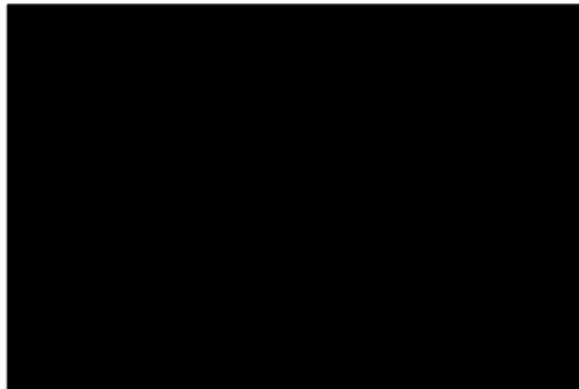

Active Area

EVERVISION	MODEL NO.		PAGE
	VGG804849-6UFLWH	SPEC SAMPLE	8

8.2 Backlight Unit

(Ta=25±2°C)

Item	Symbol	Value			Unit	Note
		Min.	Typ.	Max.		
Current of Backlight Unit	IB	-	260	-	mA	-
Voltage of Backlight Unit	VB	-	(9.0)	-	V	IB =260mA,(2)
LED Life Time(25°C)	-	50000	-	-	hr	(1)

Note (1) : LED life time is defined as under 25±2°C , when the average brightness decrease to 50% of original brightness

Note (2) : The BLU is driven by constant current, the voltage value is for reference only.

8.3 Transparent Touch panel

Electrical characteristics

Item		Value			Unit	Note
		Min.	Typ.	Max.		
Operating Voltage		3	-	5	V	-
Terminal Resistance	X-direction	200	-	1000	Ω	At connector
	Y-direction	200	-	1000	Ω	At connector
Insulation Resistance		≥ 20MΩ				at DC25V
Chatting		≤ 10 ms				At connector
Linearity		≤ 2%				(1)
Linearity Force		≤120gf less input with stylus pen (R0.8mm) Activation force guarantee area: 3 mm inside of Active Area.				
Activation Force		≤100 gf(Typical 20 gf) less individual point on with stylus pen(R0.8 mm). Activation force guarantee area: 3mm inside of Active Area.				

9. Block Diagram

9.1 TFT-LCD Module with Backlight Unit

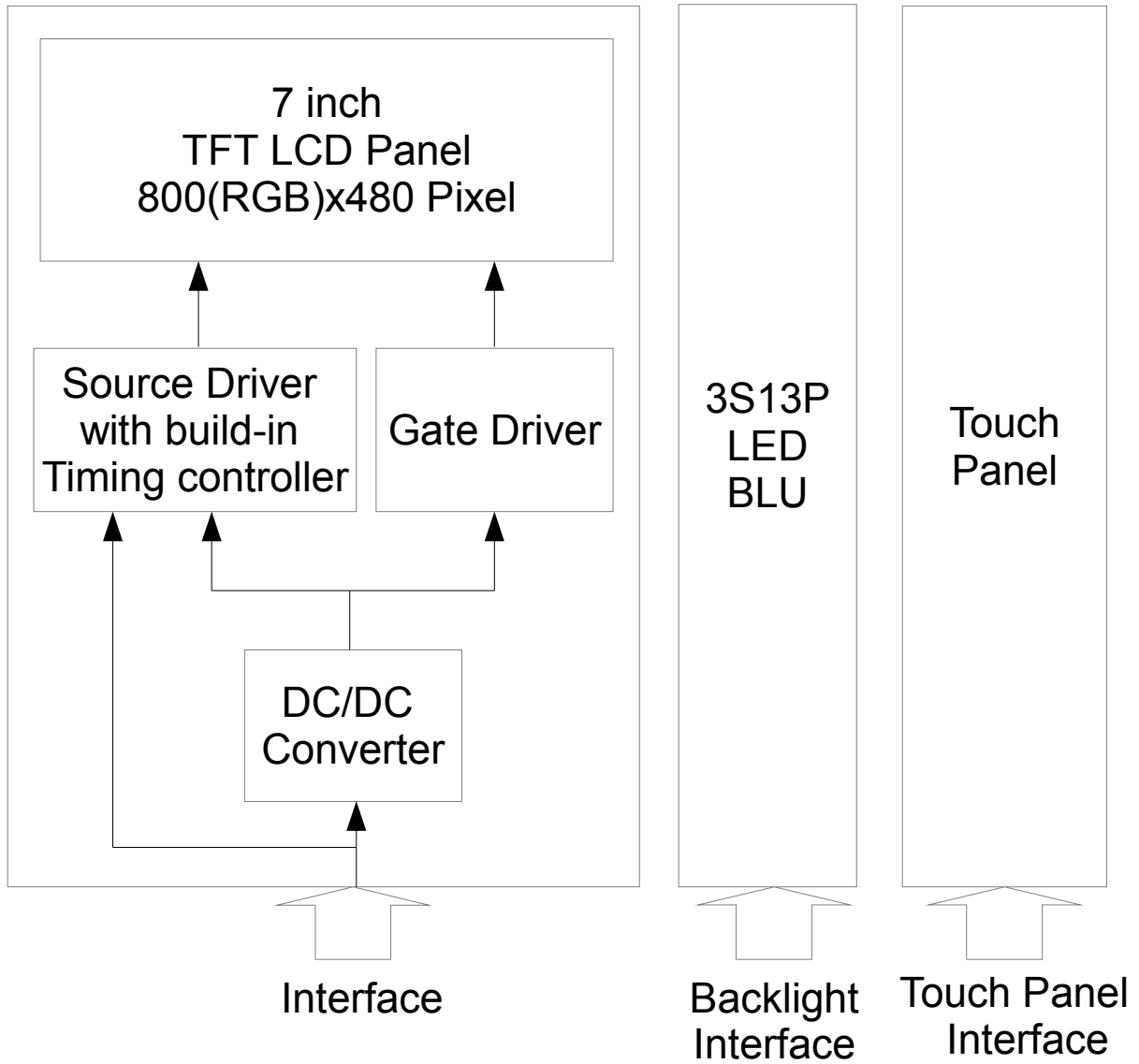

10. Input / Output Terminals Pin Assignment

10.1 TFT-LCD Module

Connector: JAE FA5B040HP1 or compatible connector

Pin No.	Symbol	I/O	Description
1	VCC	I	Power supply
2	VCC	I	Power supply
3	VCC	I	Power supply
4	VCC	I	Power supply
5	NC	I	No Connect
6	DE	I	Input data enable control
7	VSS	I	Ground
8	NC	I	No Connect
9	VSS	I	Ground
10	NC	I	No Connect
11	VSS	I	Ground
12	B5	I	Blue data(MSB)
13	B4	I	Blue data
14	B3	I	Blue data
15	VSS	I	Ground
16	B2	I	Blue data
17	B1	I	Blue data
18	B0	I	Blue data(LSB)
19	VSS	I	Ground
20	G5	I	GREEN data(MSB)
21	G4	I	GREEN data
22	G3	I	GREEN data
23	VSS	I	Ground
24	G2	I	GREEN data
25	G1	I	GREEN data
26	G0	I	GREEN data(LSB)
27	VSS	I	Ground
28	R5	I	RED data(MSB)
29	R4	I	RED data
30	R3	I	RED data

Pin No.	Symbol	I/O	Description
31	VSS	I	Ground
32	R2	I	RED data
33	R1	I	RED data
34	R0	I	RED data (LSB)
35	NC	I	No Connect
36	VSS	I	Ground
37	VSS	I	Ground
38	DCLK	I	Dot Clock
39	VSS	I	Ground
40	VSS	I	Ground

10.2 Backlight Unit

Connector: JST BHSR-02VS-1(N) or compatible connector

Pin No.	Symbol	I/O	Description	Wire Color
1	VLEDA	I	Backlight LED Anode.	Red
2	VLEDC	I	Backlight LED Cathode.	Black

10.3 Transparent Touch Panel

Connector: CVILUX CF25041D0R0-10 or compatible connector

Pin No.	Symbol
1	RIGHT
2	TOP
3	LEFT
4	BOTTOM

10.4 Color Data Input Assignment

The brightness of each primary color(red, green and blue) is based on the 6 bit gray scale data input for the color. The higher the binary input, the brighter the color. The table provides the assignment of color versus data input.

Color		Data Signal																	
		Red						Green						Blue					
		R5	R4	R3	R2	R1	R0	G5	G4	G3	G2	G1	G0	B5	B4	B3	B2	B1	B0
Basic Colors	Black	0	0	0	0	0	0	0	0	0	0	0	0	0	0	0	0	0	0
	Red	1	1	1	1	1	1	0	0	0	0	0	0	0	0	0	0	0	0
	Green	0	0	0	0	0	0	1	1	1	1	1	1	0	0	0	0	0	0
	Blue	0	0	0	0	0	0	0	0	0	0	0	0	1	1	1	1	1	1
	Cyan	0	0	0	0	0	0	1	1	1	1	1	1	1	1	1	1	1	1
	Magenta	1	1	1	1	1	1	0	0	0	0	0	0	1	1	1	1	1	1
	Yellow	1	1	1	1	1	1	1	1	1	1	1	1	0	0	0	0	0	0
	White	1	1	1	1	1	1	1	1	1	1	1	1	1	1	1	1	1	1
Gray Scale Of RED	Red(0) / Dark	0	0	0	0	0	0	0	0	0	0	0	0	0	0	0	0	0	0
	Red(1)	0	0	0	0	0	1	0	0	0	0	0	0	0	0	0	0	0	0
	Red(2)	0	0	0	0	1	0	0	0	0	0	0	0	0	0	0	0	0	0
	:	:	:	:	:	:	:	:	:	:	:	:	:	:	:	:	:	:	:
	:	:	:	:	:	:	:	:	:	:	:	:	:	:	:	:	:	:	:
	Red(61)	1	1	1	1	0	1	0	0	0	0	0	0	0	0	0	0	0	0
	Red(62)	1	1	1	1	1	0	0	0	0	0	0	0	0	0	0	0	0	0
	Red(63)	1	1	1	1	1	1	0	0	0	0	0	0	0	0	0	0	0	0
Gray Scale Of Green	Green(0) / Dark	0	0	0	0	0	0	0	0	0	0	0	0	0	0	0	0	0	0
	Green(1)	0	0	0	0	0	0	0	0	0	0	1	0	0	0	0	0	0	0
	Green(2)	0	0	0	0	0	0	0	0	0	1	0	0	0	0	0	0	0	0
	:	:	:	:	:	:	:	:	:	:	:	:	:	:	:	:	:	:	:
	:	:	:	:	:	:	:	:	:	:	:	:	:	:	:	:	:	:	:
	Green(61)	0	0	0	0	0	0	1	1	1	1	0	1	0	0	0	0	0	0
	Green(62)	0	0	0	0	0	0	1	1	1	1	1	0	0	0	0	0	0	0
	Green(63)	0	0	0	0	0	0	1	1	1	1	1	1	0	0	0	0	0	0
Gray Scale Of Blue	Blue(0) / Dark	0	0	0	0	0	0	0	0	0	0	0	0	0	0	0	0	0	0
	Blue(1)	0	0	0	0	0	0	0	0	0	0	0	0	0	0	0	0	0	1
	Blue(2)	0	0	0	0	0	0	0	0	0	0	0	0	0	0	0	0	1	0
	:	:	:	:	:	:	:	:	:	:	:	:	:	:	:	:	:	:	:
	:	:	:	:	:	:	:	:	:	:	:	:	:	:	:	:	:	:	:
	Blue(61)	0	0	0	0	0	0	0	0	0	0	0	0	1	1	1	1	0	1
	Blue(62)	0	0	0	0	0	0	0	0	0	0	0	0	1	1	1	1	1	0
	Blue(63)	0	0	0	0	0	0	0	0	0	0	0	0	1	1	1	1	1	1

10.5 Power ON/OFF Sequence

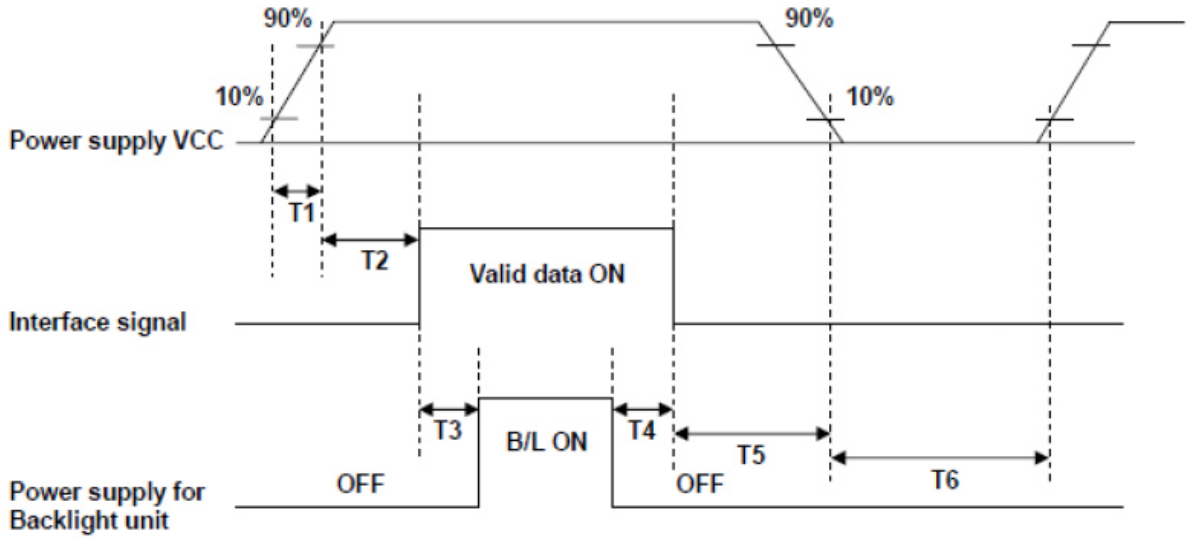

POWER SEQUENCE TABLE

Parameter	Value			Units
	Min.	Typ	Max.	
T1	0.5	-	10	ms
T2	20	-	50	ms
T3	200	-	-	ms
T4	200	-	-	ms
T5	0	-	50	ms
T6	1000	-	-	ms

11. Interface Timing

11.1 AC Electrical Characteristics

Item	Symbol	Values			Unit	Remark
		Min.	Typ.	Max.		
HS setup time	T_{hst}	8	-	-	ns	
HS hold time	T_{hhd}	8	-	-	ns	
VS setup time	T_{vst}	8	-	-	ns	
VS hold time	T_{vhd}	8	-	-	ns	
Data setup time	T_{dsu}	8	-	-	ns	
Data hole time	T_{dhd}	8	-	-	ns	
DE setup time	T_{esu}	8	-	-	ns	
DE hole time	T_{ehd}	8	-	-	ns	
DV _{DD} Power On Slew rate	T_{POR}	-	-	20	ms	From 0 to 90% DV _{DD}
RESET pulse width	T_{Rst}	1	-	-	ms	
DCLK cycle time	T_{cph}	20	-	-	ns	
DCLK pulse duty	T_{cwh}	40	50	60	%	

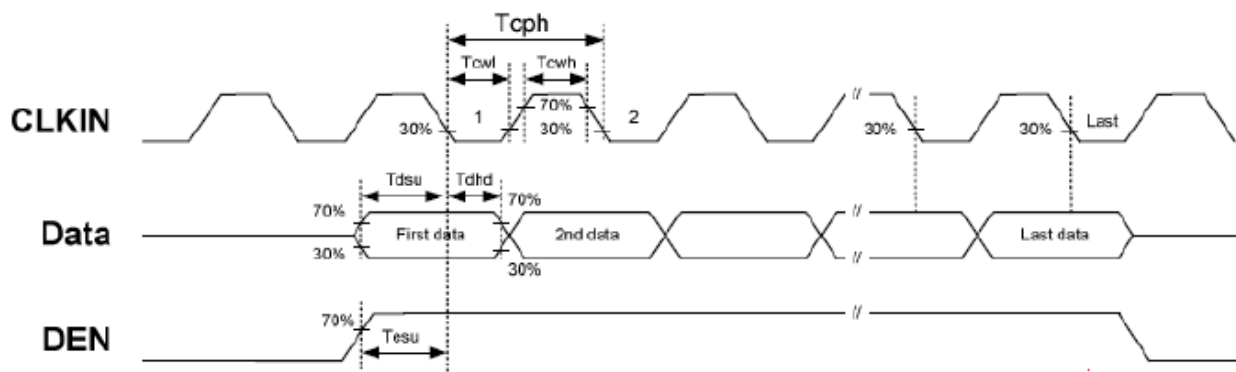

EVERVISION	MODEL NO.		PAGE
	VGG804849-6UFLWH	SPEC SAMPLE	15

11.2. Timing

Item	Symbol	Values			Unit	Remark
		Min.	Typ.	Max.		
Horizontal Display Area	thd	-	800	-	DCLK	
DCLK Frequency	fclk	26.4	33.3	46.8	MHz	
One Horizontal Line	th	862	1056	1200	DCLK	
HS pulse width	thpw	1	6	40	DCLK	
HS Blanking	thb	46	46	46	DCLK	
HS Front Porch	thfp	16	204	354	DCLK	

Item	Symbol	Values			Unit	Remark
		Min.	Typ.	Max.		
Vertical Display Area	tvd	-	480	-	TH	
VS period time	tv	510	525	650	TH	
VS pulse width	tvpw	1	3	20	TH	
VS Blanking	tvb	23	23	23	TH	
VS Front Porch	tvfp	7	22	147	TH	

Note: Frame rate is $60 \pm 5\text{Hz}$

11.3. Data Input Format

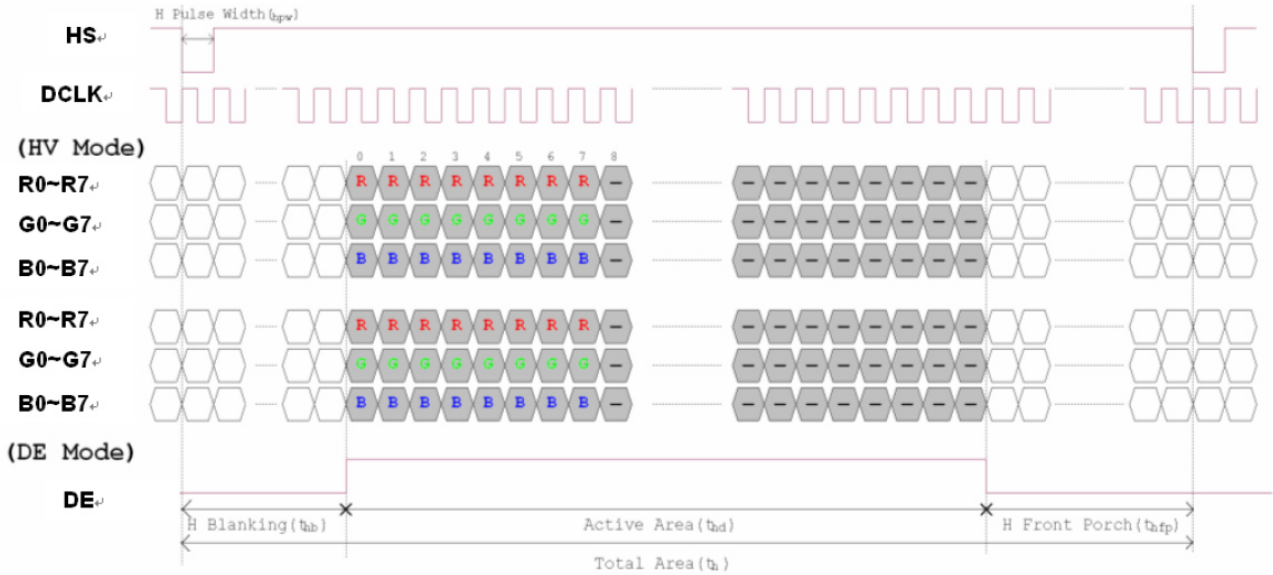

Figure 1. Horizontal input timing diagram

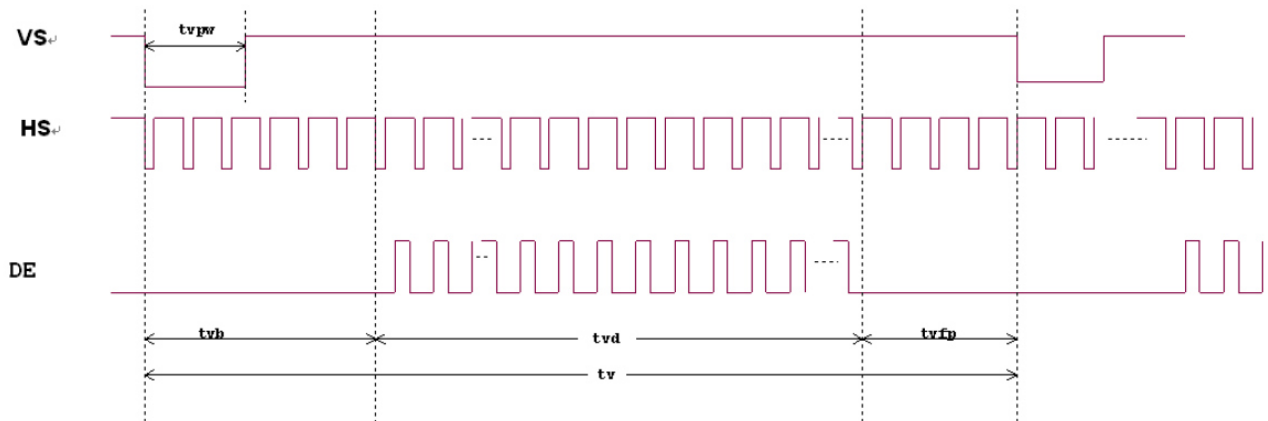

Figure 2. Vertical input timing diagram

12. Optical Characteristics

The optical characteristics should be measured in a dark environment (≤ 1 lux) or equivalent state with the methods shown in Note (4).

Item		Symbol	Conditions	Min.	Typ.	Max.	Unit	Note
Contrast Ratio		CR	$\theta_x=0^\circ, \theta_y=0^\circ$ Viewing Normal Angle	700	(1000)	-	-	(2)
Response Time		$T_R + T_F$		-	20	30	ms	(3)
Luminance(Center)		Y		600	(800)	-	cd/m ²	(4)
Brightness uniformity		BUNI		70	(75)	-	%	(5)
Color Chromaticity	Red	Rx		0.565	0.615	0.665	-	(1),(4)
		Ry	0.320	0.370	0.420	-		
	Green	Gx	0.310	0.360	0.410	-		
		Gy	0.550	0.600	0.650	-		
	Blue	Bx	0.095	0.145	0.195	-		
		By	0.050	0.100	0.150	-		
	White	Wx	0.275	0.325	0.375	-		
		Wy	0.310	0.360	0.410	-		
Viewing Angle	Horizontal	θ_{x+}	CR \geq 10	60	(70)	-	deg.	
		θ_{x-}		60	(70)	-		
	Vertical	θ_{y+}		50	(60)	-		
		θ_{y-}		60	(70)	-		

Note (1) Definition of Viewing Angle (θ_x , θ_y):

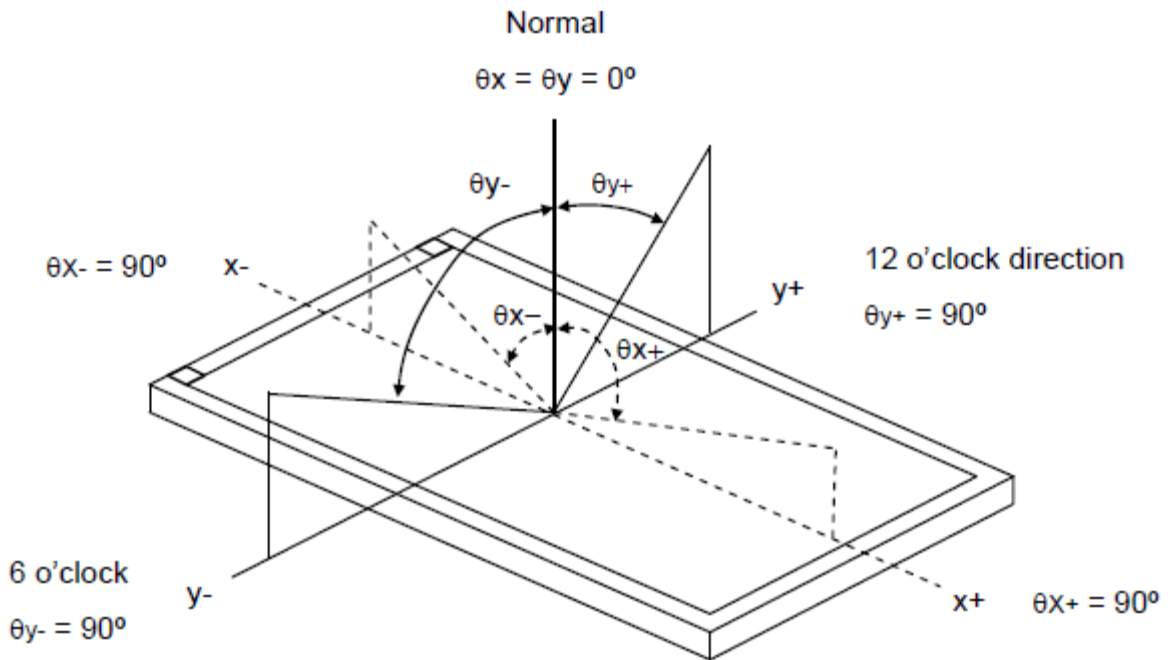

Note (2) Definition of Contrast Ratio (CR):

$$\text{Contrast ratio (CR)} = \frac{\text{Luminance measured when LCD on the "White" state}}{\text{Luminance measured when LCD on the "Black" state}}$$

Note (3) Definition of Response Time (T_R , T_F):

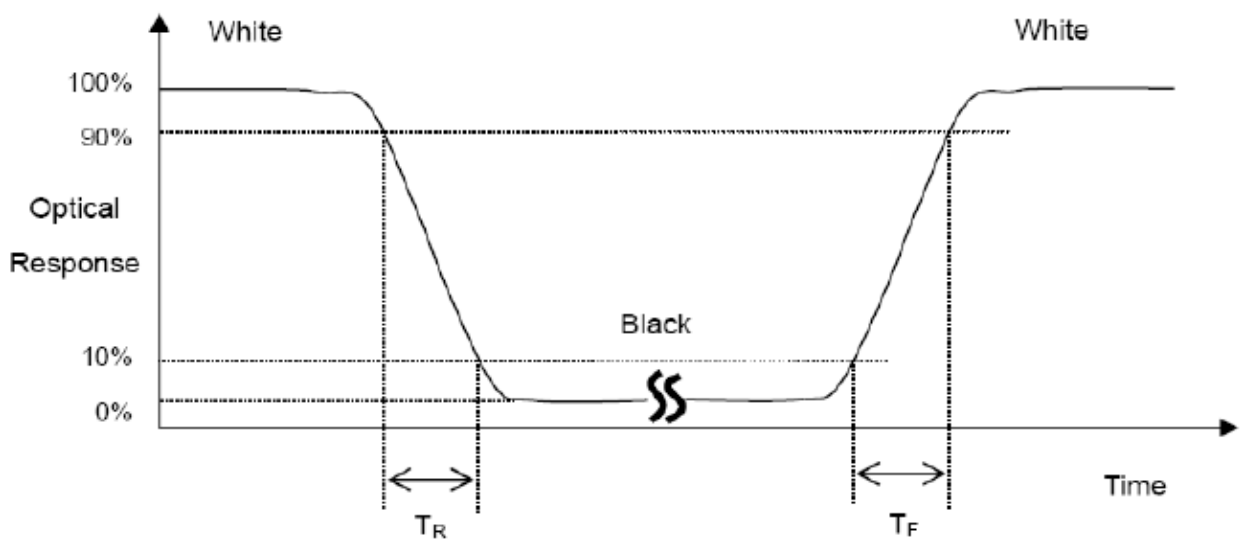

Note (4) Measurement Set-Up:

The LCD module should be stabilized at a given temperature for 30 minutes to avoid abrupt temperature change during measuring. In order to stabilize the luminance, the measurement should be executed after lighting Backlight for 30 minutes in a dark room or equivalent condition.

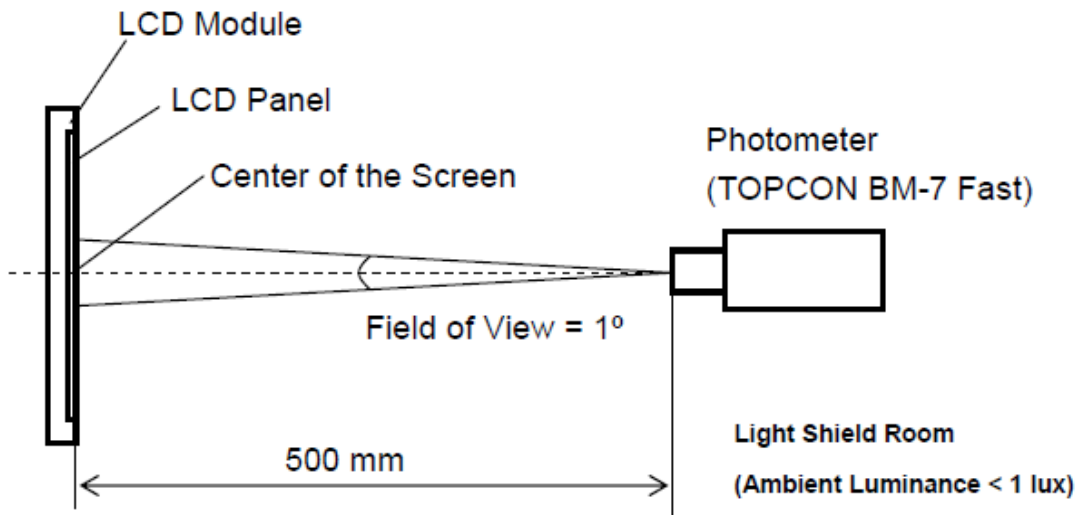

Note (5) Definition of brightness uniformity

Brightness uniformity=(Min Luminance of 9 points)/(Max Luminance of 9 points)×100%

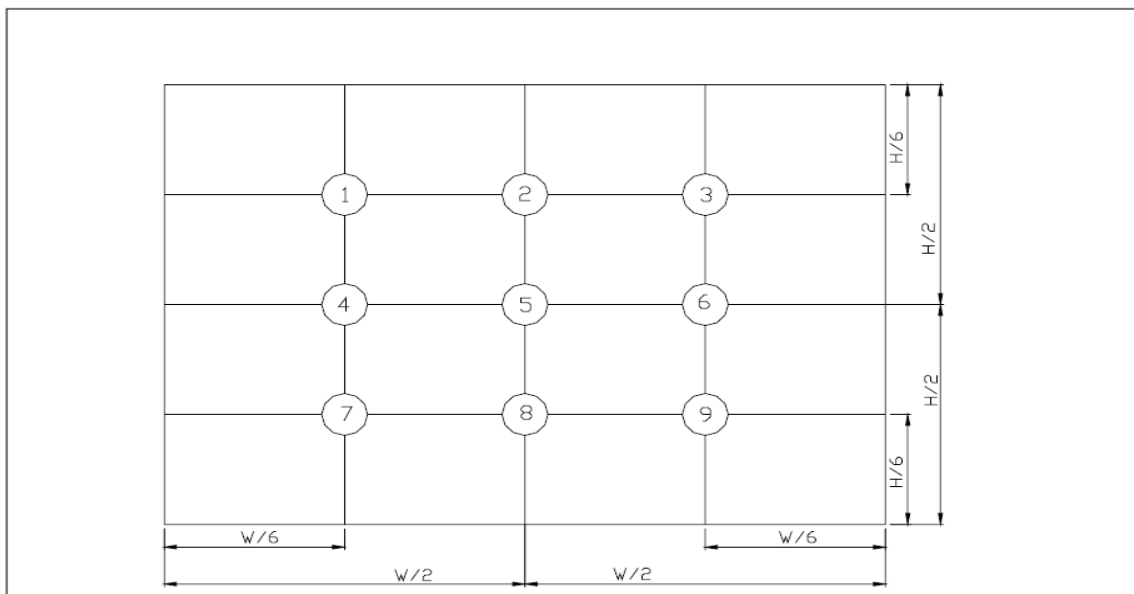

(單位 : mm)

13. Reliability Test

No.	Test Items	Test Condition	Remark
1	High Temperature Storage Test	$T_a = 80^{\circ}\text{C}$ 240 hours	(1),(3),(4)
2	Low Temperature Storage Test	$T_a = -30^{\circ}\text{C}$ 240 hours	(1),(3),(4)
3	High Temperature Operation Test	$T_s = 70^{\circ}\text{C}$ 240 hours	(2),(3),(4)
4	Low Temperature Operation Test	$T_a = -20^{\circ}\text{C}$ 240 hours	(1),(3),(4)
5	High Temperature and High Humidity Operation Test	$T_a = 60^{\circ}\text{C}$ 90%RH 240 hours	(3), (4)
6	Electro Static Discharge Test (non-operating)	-Panel Surface/Top Case : 150pF, 330 Ω Air : $\pm 15\text{kV}$, Contact: $\pm 8\text{kV}$	(3)
7	Mechanical Shock Test (non-operating)	Half sine wave, 100G, 6ms 3 times shock of each six surfaces	(3)
8	Vibration Test (non-operating)	Sine wave:10 ~ 55 ~ 10Hz amplitude:1.5mm 3 axis, 2 hours/axis	(3)
9	Thermal Shock Test (non-operating)	-20°C (30min) ~ 70°C (30min) ,10 cycles	(3) , (4)
10	Drop Test(with Carton)	Height : 80 _{cm} 1 corner, 3 edges, 6 surfaces	(3)

Note 1 : T_a is the ambient temperature of samples.

Note 2 : T_s is the temperature of panel' s surface.

Note 3 : In the standard condition, there shall be no practical problem that may affect the display function.
After the reliability test, the product only guarantees operation, but don' t guarantee all of the cosmetic specification.

Note 4 : Before cosmetic and function test, the product must have enough recovery time, at least 2 hours at room temperature.

14. Packaging

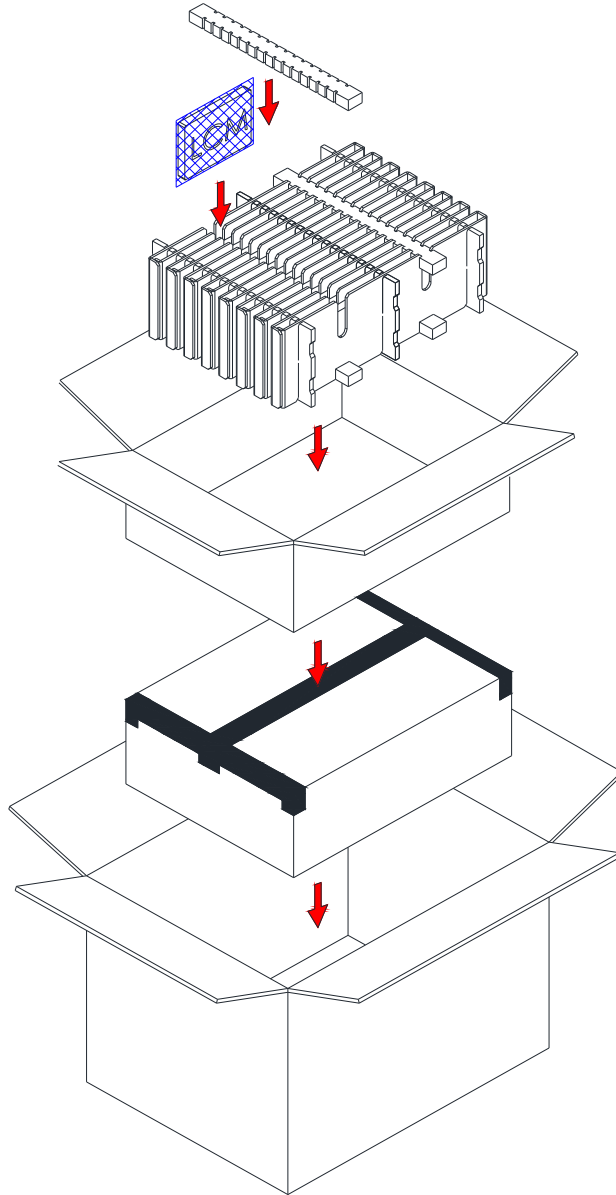

PARTS LIST					
	ITEM	SIZE(LxWxH) unit:mm	MATERIAL	Q.T.Y	NOTE
1	STATIC SHIEDING BAGS	300.0x145.0x0.09		60	
2	EPE PAD	345.0x30.0x20.0	EPE	8	
3	CARD BOARD	345.0x150.0x3.5	CARTON	6	
4	CARD BOARD	450.0x23.0x150.0	CARTON	16	
5	INTERNAL BOX	455.0x350.0x164.0	CARTON	2	
6	EXTERNAL BOX	475.0x370.0x375.0	CARTON	1	
7	PRODUCT	166.6x109.4x11.5		60	

	MODEL NO.		PAGE
	VGG804849-6UFLWH	SPEC SAMPLE	22

15. Precautions

15.1 Assembly and Handling Precautions

- (1) Do not apply rough force such as bending or twisting to the module during assembly.
- (2) It's recommended to assemble or to install a module into the user's system in clean working areas. The dust and oil may cause electrical short or worsen the polarizer.
- (3) Don't apply pressure or impulse to the module to prevent the damage of LCD panel and Backlight.
- (4) Always follow the correct power-on sequence when the LCD module is turned on. This can prevent the damage and latch-up of the CMOS LSI chips.
- (5) Do not plug in or pull out the I/F connector while the module is in operation.
- (6) Do not disassemble the module.
- (7) Use a soft dry cloth without chemicals for cleaning, because the surface of polarizer is very soft and easily scratched.
- (8) Moisture can easily penetrate into LCD module and may cause the damage during operation.
- (9) High temperature or humidity may deteriorate the performance of LCD module. Please store LCD module in the specified storage conditions.
- (10) When ambient temperature is lower than 10°C, the display quality might be reduced. For example, the response time will become slow.

15.2 Safety Precautions

- (1) If the liquid crystal material leaks from the panel, it should be kept away from the eyes or mouth. In case of contact with hands, skin or clothes, it has to be washed away thoroughly with soap.
- (2) After the module's end of life, it is not harmful in case of normal operation and storage.

15.3 Terms of Warrant

- (1) Acceptance inspection period
The period is within one month after the arrival of contracted commodity at the buyer's factory site.
- (2) Applicable warrant period
The period is within twelve months since the date of shipping out under normal using and storage conditions.

	MODEL NO.		PAGE
	VGG804849-6UFLWH	SPEC SAMPLE	23

15.4 Caution

This Evervision LCD module has been specifically designed for use only in electronic devices in the areas of audio control, office automation, industrial control, home appliances, etc. The modules should not be used in applications where module failure could result in physical harm or loss of life, and Evervision expressly disclaims any and all liability relating in any way to the use of the module in such applications.

15.5 Precautions of Storage

If the displays are going to be stored for years, please be aware the following notices.

- (1) Please store the displays in a dark room to avoid any damages from sunlight and other sources of UV light.
- (2) The recommended long term storage temperature is between 10 ~35°C and <60% humidity to avoid causing bubbles between polarizer and LCD glasses, and polarizer peeling from LCD glasses.
- (3) It would be better to keep the displays in the container, which is shipped from Evervision, and do not unpack it.
- (4) Please do not stick any labels on the display surface for a long time, especially on the polarizer.

15.6 Cautions for installing and assembling

Structure, and Area definition: The structure and the performance guaranteed areas of this touch panel are defined below.

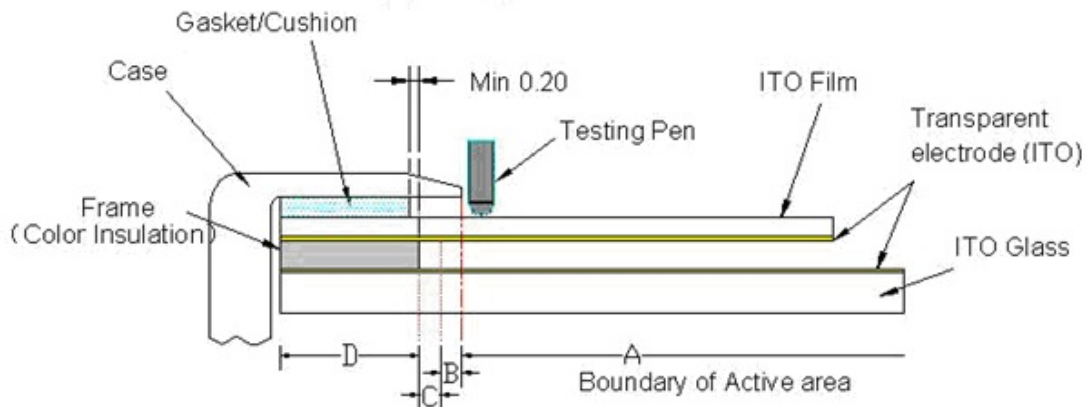

❖ Area-(A) : Active area

The area guarantees a touch panel operation with the following characteristics when pressed.

(i) Operation force (ii) Electric characteristics (iii) Tapping durability (iv) Pen sliding durability

❖ Area-(B) : Operation non-guaranteed area

The area does not guarantee a touch panel operation and its function. When this area is pressed, touch panel shows degradation of its performance and durability such as a pen sliding durability becomes about one-tenth compared with the active area (Area- (A) as guaranteed area) and its operation force requires about double. About 0.5 mm outside from a boundary of the active area corresponds to this area.

❖ Area-(C) : Pressing prohibition area

The area forbids pressing because an excessive load is applied to a transparent electrode and a serious damage is given to a touch panel function by pressing. About 0.5mm outside from a boundary of Area-(B)" the operation non-guaranteed area" corresponds to this area.

❖ Area-(D) : Non-Active area (Frame)

The area does not activate even if pressed.

(Remark: In order to prevent unusual performance degradation and malfunction of a touch panel, please inspect firstly whether the set case designing and touch panel assembling method are reasonable or not, and then start to install and assemble after surely confirming the item "15.4 Cautions for installing and assembling".)

❖ Area-(B)+Area-(C): Sensitive area

Area-(B) and area-(C) both belong to the sensitive area. This area has a clearance between top and bottom contact side. Great press resulting in transparent electrode cracks, function defect to be exact, will deform surface transparent electrode. Please think about structure of sensitive area and case in order to avoid terminal user to fail to touch this area.

Remark: Please add a layer of gasket/ cushion around it before assembling touch panel. Take care that gasket/ cushion's location should be in the limits of Frame area's location. Min. 0.2mm outside from an inner boundary of Frame area corresponds to this area:

- ① If designed case's size is bigger than active area's size, terminal user could touch sensitive area to damage touch panel;
- ② If designed case's size is smaller than active area's size, ITO transparent electrode will not damage when sliding test on the edge of case as sensitive area is covered by case around. But cushion/gasket's thickness looks so important when case enters into active area: If too thick, the clearance of case and surface transparent electrode will be so big as to affect touch panel's appearance. If too thin, the case will be pressed directly on the touch panel's surface, which have to be damaged resulting in short circuit. Therefore, you'd better keep clearance of 0.2-0.3 mm between case and transparent electrode.

15.7 Operation Prohibit

Not Suggested Pen Input Position On Touch Panel

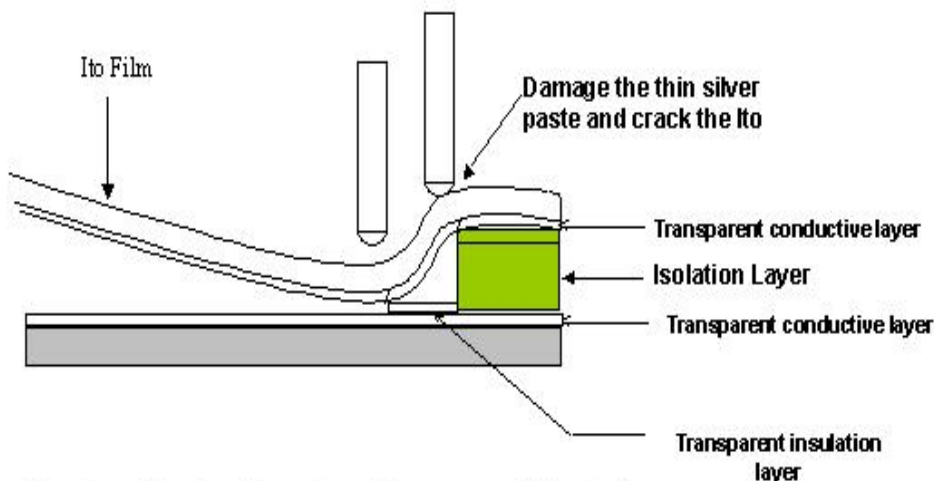

Pen input load on the edge of transparent insulation area might damage the ITO of ITO Pet- Film and reduce the durability of touch panel

16.Outline Drawing

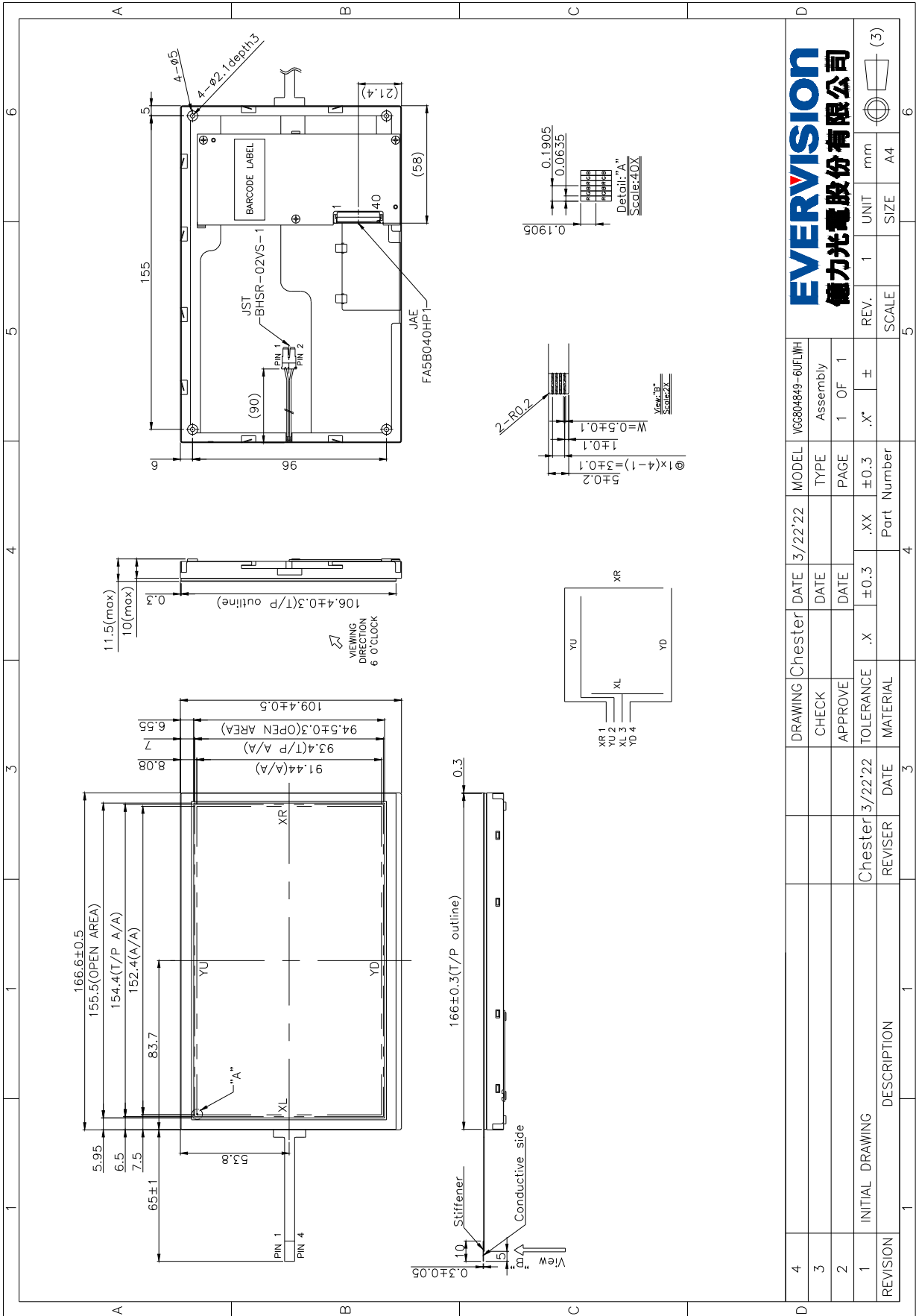

EVERVISION
 德力光電股份有限公司

4	DRAWING	Chester	DATE	3/22'22	MODEL	VGG804849-6UFLWH
3	CHECK		DATE		TYPE	Assembly
2	APPROVE		DATE		PAGE	1 OF 1
1	INITIAL DRAWING	Chester	3/22'22	±0.3	.XX	±0.3
REVISION	DESCRIPTION	REVISOR	DATE	3	MATERIAL	Part Number
				4		5
				1		6

REV.	1	UNIT	mm
SCALE		SIZE	A4
			(3)

17. Definition of Labels

The bar code nameplate is pasted on each module as illustration, and its definitions are as following explanation.



(a) Module Name : VGG804849-6UFLWH

(b) Serial ID :

A B C D E F G H I J K L

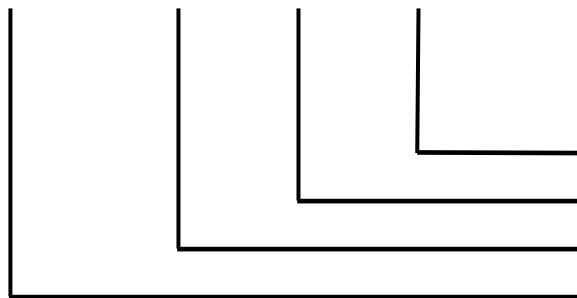

Serial No.
 Factory Code
 Manufactured Date
 Screen Size

Serial ID includes the information as below:

(a) Screen size (Diagonal): Inch Code (ABCD)

3.5" → 0350

10.4" → 1040

(b) Manufactured Date: Year, Month, Day (EFG)

Year (E)

Year	2000	2001	2002	2003	2004	2005	2006	2007	2008	2009
Mark	0	1	2	3	4	5	6	7	8	9
Year	2010	2011	2012	2013	2014	2015	2016	2017	2018	2019
Mark	A	B	C	D	E	F	G	H	I	J
Year	2020	2021	2022	2023	2024	2025	2026	2027	2028	2029
Mark	K	L	M	N	O	P	Q	R	S	T
Year	2030	2031	2032	2033	2034	2035				
Mark	U	V	W	X	Y	Z				

Month (F)

Month	Jan.	Feb.	Mar.	Apr.	May	Jun.	Jul.	Aug.	Sep.	Oct.	Nov.	Dec.
Mark	1	2	3	4	5	6	7	8	9	A	B	C

Day (G)

Day	1	2	3	4	5	6	7	8	9	10	11	12	13	14	15	16
Mark	1	2	3	4	5	6	7	8	9	A	B	C	D	E	F	G
Day	17	18	19	20	21	22	23	24	25	26	27	28	29	30	31	
Mark	H	I	J	K	L	M	N	O	P	Q	R	S	T	U	V	

(c) Factory Code (H) :

For EVERVISION internal use.

(d) Serial No. (IJKL) :

Manufacturing sequence of product, for example : 0001~9999.

18. Incoming Inspection Standards

1.The environmental condition of inspection

The environmental condition and visual inspection shall be conducted as below.

- (1) Ambient temperature $25 \pm 5^{\circ}\text{C}$
- (2) Humidity: 25 ~ 75 % RH
- (3) Viewing distance is approximately 30 ~ 40 cm
- (4) Viewing angle is normal to the LCD panel as Fig _1 ($\pm 45^{\circ}$)
- (5) Ambient Illumination: 200 ~ 500 Lux for external appearance inspection

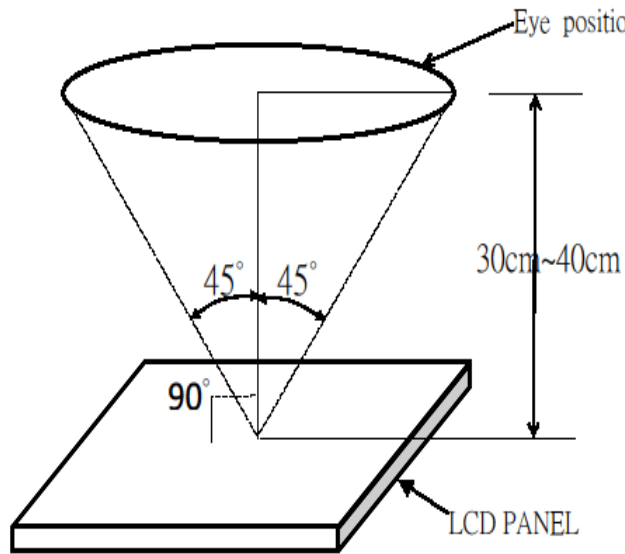

Fig_1

2.The defects classify of AQL as following:

- (1) Test method: According to ANSI/ASQC Z 1.4 .General Inspection Level II take a single time
- (2) The defects classify of AQL as following:

Class of defects	AQL	Definition
Major	0.65%	It is defect that is likely to result in failure or to reduce materially the usability of the intended function.
Minor	1.5%	It is a defect that will not result in functioning problem with deviation classified.

3. Inspection Parameters

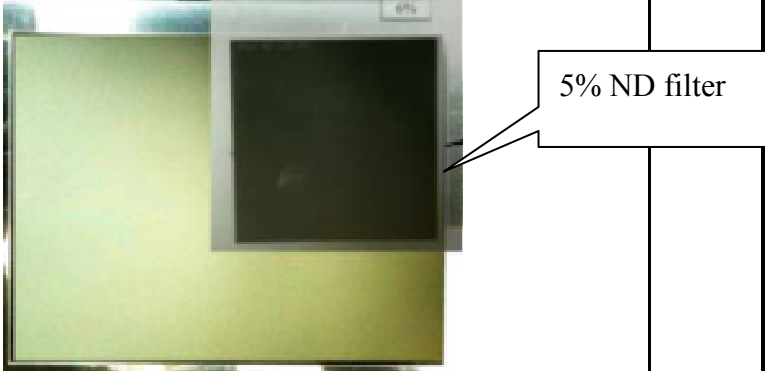
Item		Specification/Description			Note	
Display	Function	No Display			-	
		Malfunction			-	
Operating	Contrast ratio	Out of Spec			-	
	Line defect	No obvious Vertical and Horizontal line defect in bright, dark and colored.			-	
	Point Defect (red ,green ,blue ,dark ,white)	Item	Acceptable number			Note: 1、4、 5、6
			A	B	Total	
		BRIGHT DOT	$N \leq 3$	$N \leq 3$	$N \leq 8$	
		DARK DOT	$N \leq 5$	$N \leq 6$		
		TOTAL DOT	$N \leq 5$	$N \leq 6$		
		2 bright dots adjacent	NOT ALLOWED			
		2 dark dots adjacent	$N \leq 1$			
	THREE OR MORE ADJACENT DOT	NOT ALLOWED				
MURA	Has the non-uniform phenomenon 			-		
	Not visible through 5% ND filter in 50% gray or judge by limit sample if necessary 			-		

Item		Specification/Description			Note
Touch Panel	Scratch	L(mm)	W(mm)	Acceptable number	Note:2
		$L \leq 10$	$W < 0.05$	Disregard	
			$0.05 \leq W < 0.1$	$N \leq 4$	
	Foreign Materials (Linear shape)	$L \leq 10$	$W < 0.05$	Disregard	Note:2
			$0.05 \leq W < 0.1$	$N \leq 3$	
			$W \geq 0.1$	0	
	Foreign Materials (Circular shape)	Dimension(mm)		Acceptable number	Note:3
		$D \leq 0.25$		Disregard	
		$0.25 < D \leq 0.5$		$N \leq 6$	
	Glass chipping		$a \leq 5.0\text{mm}$ $b \leq 3.0\text{mm}$ $c \leq t$ (t : Glass think)		Note:7
$a \leq 3.0\text{mm}$ $b \leq 3.0\text{mm}$ $c \leq t$ (t : Glass think)			Note:7		
Newton-ring	(In case of doubtful situations) Observe on 60° from the product surface under a white Fluorescent lamp (3-wavelength lamp). 	Average diameter $\leq 1/3$ Touch Panel area Disregard.		Note:7	
Membrane Drum		$H \leq 0.4\text{mm}$		-	

Item		Specification/Description			Note
External Inspection (non-operating or operating)	Polarizer Scratch (in display area)	L(mm)	W(mm)	Acceptable number	Note:2
		-	$W \leq 0.07$	Disregard	
		$L \leq 5$	$0.07 < W \leq 0.1$	4	
		$L > 5$	$W > 0.1$	0	
	Polarizer dent or bubble (in display area)	Dimension(mm)		Acceptable number	Note:3
		$D \leq 0.3$		Disregard	
		$0.3 < D \leq 0.5$		4	
	Line Shape (Particles and Lint in display area)	L(mm)	W(mm)	Acceptable number	Note:2
		-	$W \leq 0.07$	Disregard	
		$L \leq 5$	$0.07 < W \leq 0.1$	4	
	Dot Shape (Particle in Display area)	Dimension(mm)		Acceptable number	Note:3
		$D \leq 0.3$		Disregard	
$0.3 < D \leq 0.5$		4			

Note1. The definition of dot defect : The dot defect was judged after repair and the size of a defective dot over 1/2 of whole dot is regarded as one defective dot.

Note2.

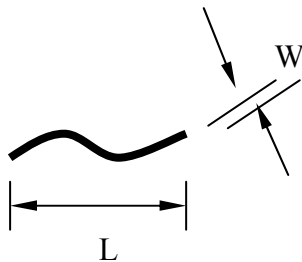

Note3. D : Diameter $D = (a+b)/2$

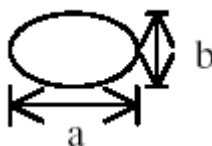

Note4. Bright dot is defined through 2% transmission ND Filter as following.

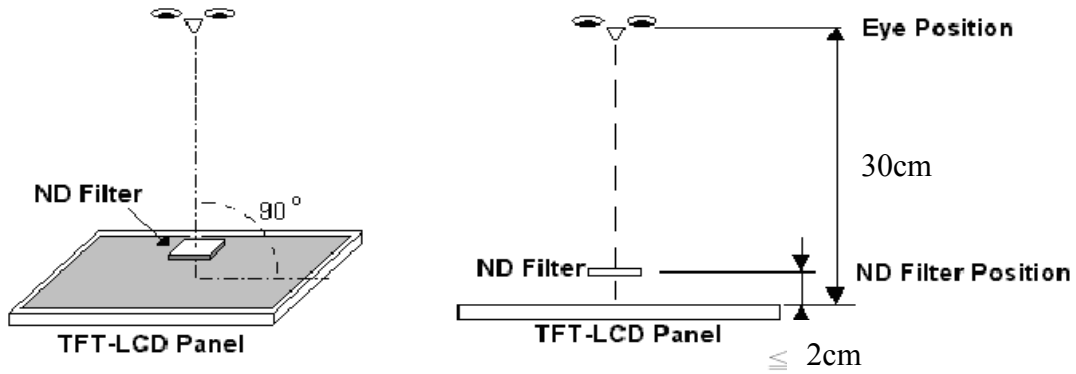

Note5. ADJACENT DOT



Note6.

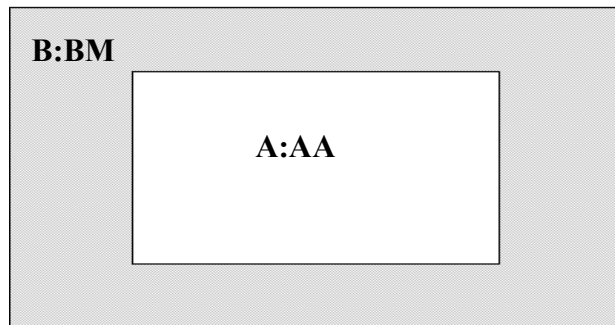

4. Handling of LCM

- (1) Don't give external shock.
- (2) Don't apply excessive force on the surface.
- (3) Liquid in LCD is hazardous substance. Must not lick and swallow. when the liquid is attach to your hand, skin, cloth etc. Wash it out thoroughly and immediately.
- (4) Don't operate it above the absolute maximum rating.
- (5) Don't disassemble the LCM.