

01 x2pcs

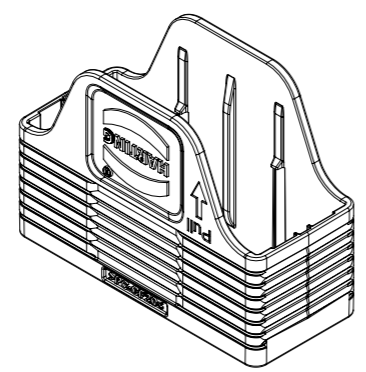

02 (enclosed) x1 piece

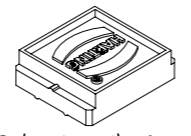

03 (enclosed) x2 pcs

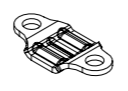

04 (enclosed) x1 piece



05 (enclosed) x2 pcs

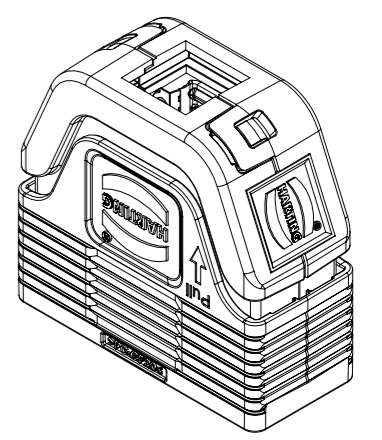

05	--	ISO 7050-ST2,2x6,5-A2-20H-F-H	x2
04	--	D-Sub ca-clamp f 9P, 15P hood	x1
03	--	plastic metallized blank piece 9P-37P	x2
02	--	D-Sub NAH 15P Moveable cover	x1
01	--	D-sub NAH 15P Hood metallized	x2
1	09 67 015 0210	D-Sub_CCH_S2_PP_PL_PLA	1 set
ITEM NO.	PART NUMBER	PART NAME	QTY

	All rights reserved Department EL PD	All Dimensions in mm Original Size DIN A3		Scale 1:1	Free size tol.	Ref. Sub.			
		Created by wene	Inspected by luok	Standardisation	Date 19-Mar-2025	State 40 - Released	Doc-Key / ECM-Nr. DS00244372		
HARTING D-32339 Espelkamp		Title D-Sub_CCH_S2_PP_PL_PLA			Type TB	Design Number DS00244372	SAP Mat. Number 09670150210	Rev. C	Page 1/1