

05	--	ISO 7050-ST2,2x6,5-A2-20H-F-H	x2
04	--	D-Sub ca-clamp for 25P, 37P, 50P hood	x1
03	--	plastic metallized blank piece 9P-37P	x2
02	--	D-Sub NAH 25P Moveable cover	x1
01	--	D-sub NAH 25P Hood coding metallized+locking spring	x2
1	09 67 025 0210 160	D-Sub_CCH_S3_PP_PL_PLA_FC	1 set
ITEM NO.	PART NUMBER	PART NAME	QTY

Recommended assembly:

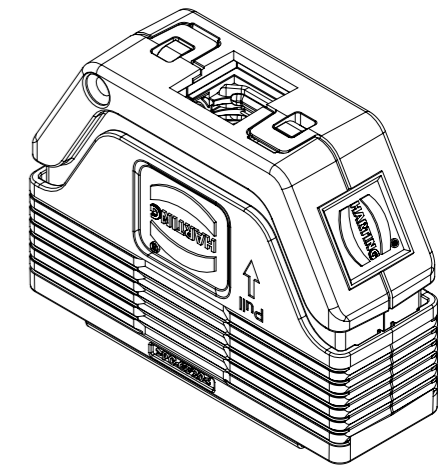
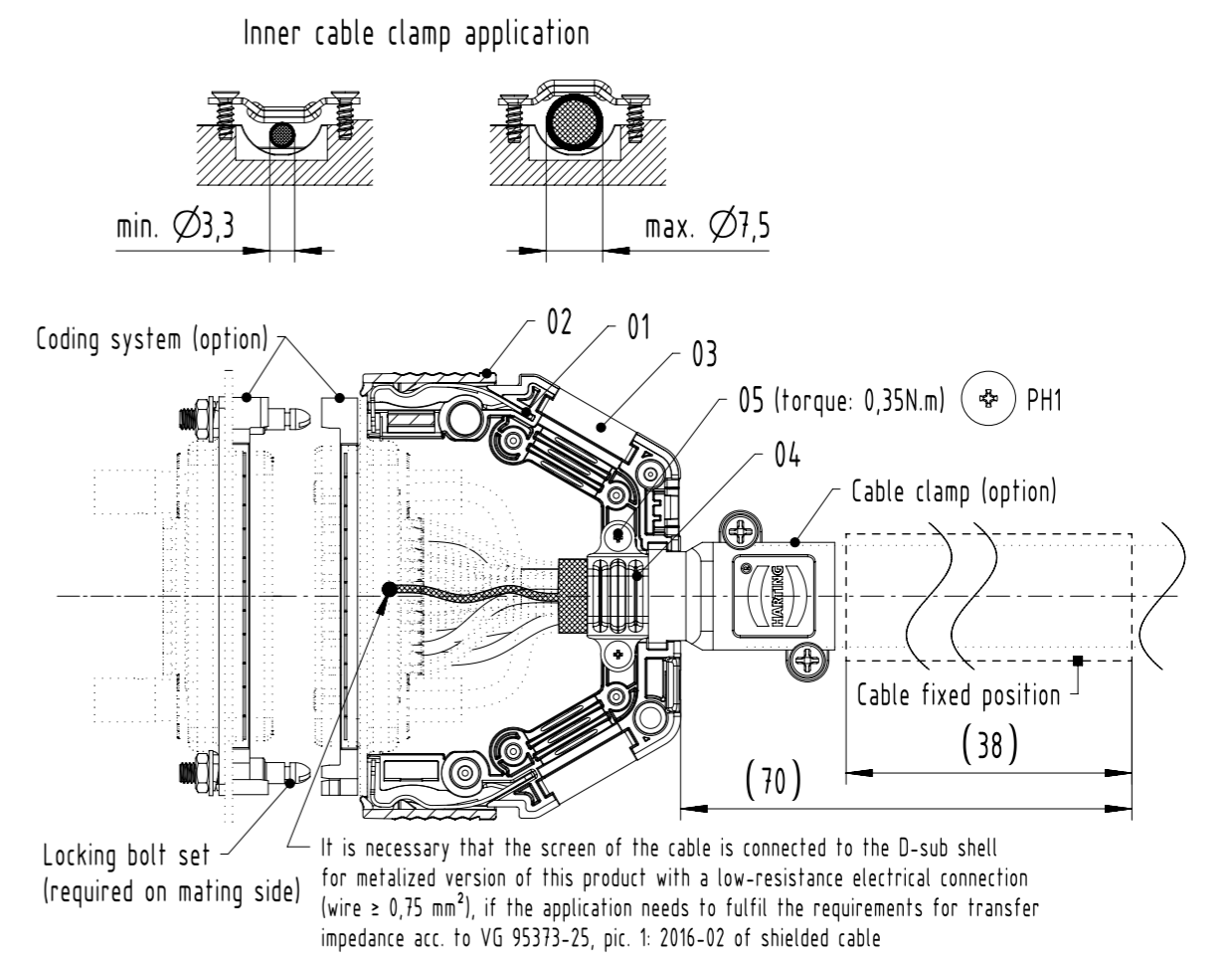

	All rights reserved Department EL PD	All Dimensions in mm Original Size DIN A3		Scale 1:1	Free size tol.	Ref. Sub.
		Created by wene	Inspected by luok	Standardisation	Date 19-Mar-2025	State 40 - Released
HARTING D-32339 Espelkamp		Title D-Sub_CCH_S3_PP_PL_PLA_FC			Doc-Key / ECM-Nr. DS00243021	
Type TB	Design Number DS00243021	SAP Mat. Number 09670250210160	Rev. D	Page 1/1		