



SPECIFICATIONS

CUSTOMER	:	SCHUKAT
MASS PRODUCTION CODE	:	SMMH0701024600S-C20
SAMPLE VERSION	:	01
SPECIFICATIONS EDITION	:	002
DRAWING NO. (Ver.)	:	SMMH0701024600S-C20-WX-B

Customer Approved

Date:

Approved	Checked	Designer
 罗潇	闫伟	朱海

- Preliminary specification for design input
- Specification for sample approval



Contents

1. SPECIFICATIONS

- 1.1 Features
- 1.2 Mechanical Specifications
- 1.3 Absolute Maximum Ratings
- 1.4 DC Electrical Characteristics
- 1.5 Optical Characteristics
- 1.6 Backlight Characteristics
- 1.7 CTP Characteristics
- 1.8 EEPROM Information

2. MODULE STRUCTURE

- 2.1 Interface Pin Description
- 2.2 Timing Characteristics

3. QUALITY ASSURANCE SYSTEM

- 3.1 Quality Assurance Flow Chart
- 3.2 Inspection Specification

4. RELIABILITY TEST

- 4.1 Reliability Test Condition

5. PRECAUTION RELATING PRODUCT HANDLING

- 5.1 Safety
- 5.2 Handling
- 5.3 Storage
- 5.4 Terms of Warranty

Appendix : 1. LCM Drawing

Note : For detailed information please refer to IC data sheet :

Primacy(TFT LCD):EK79001+EK73215



1. SPECIFICATIONS

1.1 Features

Item	Standard Value
Display Type	1024*600
LCD Type	Normally black, Transmissive type
Screen size(inch)	7 inch
Viewing Direction	FREE
Other(controller/driver IC)	EK79001+EK73215
Interface	RGB

1.2 Mechanical Specifications

Module

Item	Standard Value	Unit
Outline Dimension	181.91(W) × 113.62(H) × 7.57(D) mm	mm

TFT LCD

Item	Standard Value	Unit
Active Area	154.21(H)×85.92(V)	mm



1.3 Absolute Maximum Ratings

Module

Item	Symbol	Condition	Min.	Max.	Unit
Operating Temperature	T _{OP}	-	-30	80	°C
Storage Temperature	T _{ST}	-	-30	80	°C

1.4 DC Electrical Characteristics

Module

GND = 0V, Ta = 25°C

Item	Symbol	Condition	Min.	Typ.	Max.	Unit
Digital Supply Voltage	VDD	-	3.0	3.3	3.6	V
Input H/L Level Voltage	VIH	-	0.7VDD	-	VDD	V
	VIL	-	0	-	0.3VDD	V
Output H/L Level Voltage	VOH	-	VDD-0.4	-	-	V
	VOL	-	-	-	GND+0.4	V
Supply Current	IDD	-	-	200	250	mA



1.5 Optical Characteristics

TFT LCD Module

VDD= 3.3 V, Ta=25°C

Item		Symbol	Condition	Min.	Typ.	Max.	unit	-
Response time	Tr+Tf	25°C	-	-	25	35	ms	-
Viewing angle	Top	θY+	CR ≥ 10	80	-	-	Deg.	Note 4
	Bottom	θY-		80	-	-		
	Left	θX-		80	-	-		
	Right	θX+		80	-	-		
Contrast ratio		CR		800	1000	-	-	Note 3
Color of CIE Coordinate (B/L & LCD&CTP)	White	X	IF=200mA	-0.05	0.310	+0.05	-	Note1
		Y			0.350			
	Red	X			0.600			
		Y			0.350			
	Green	X			0.340			
		Y			0.600			
	Blue	X			0.159			
		Y			0.110			
Average Brightness Pattern=white display (B/L & LCD&CTP)		IV	IF=200mA	800	1000	-	cd/m ²	Note1
Uniformity (B/L & LCD&CTP)		△B	IF=200mA	75	-	-	%	Note1

Note 1:

*1 : $\Delta B = B(\min) / B(\max) * 100\%$

*2 : Measurement Condition for Optical Characteristics:

a : Environment: 25°C±5°C / 60±20%R.H , no wind , dark room below 10 Lux at typical lamp current and typical operating frequency.

b : Measurement Distance: 500 ± 50 mm , (θ= 0°)

c : Equipment: TOPCON BM-7 fast , (field 1°) , after 10 minutes operation.

d : The uncertainty of the C.I.E coordinate measurement ±0.01 , Average Brightness ± 4%

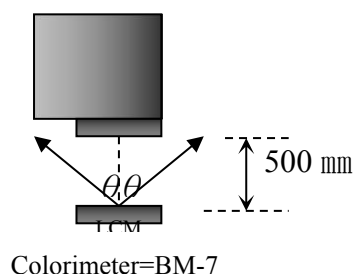
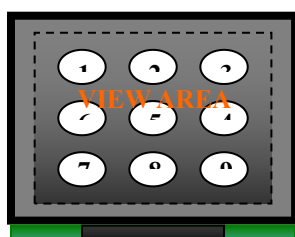



To be measured at the center area of panel with a viewing cone of 1° by Topcon luminance meter BM-7, after 10 minutes operation (module)

Note2: Definition of response time:

The output signals of photo detector are measured when the input signals are changed from “black” to “white”(falling time) and from “white” to “black”(rising time), respectively. The response time is defined as the time interval between the 10% and 90% of Amplitudes.

Refer to figure as below:

Normally White

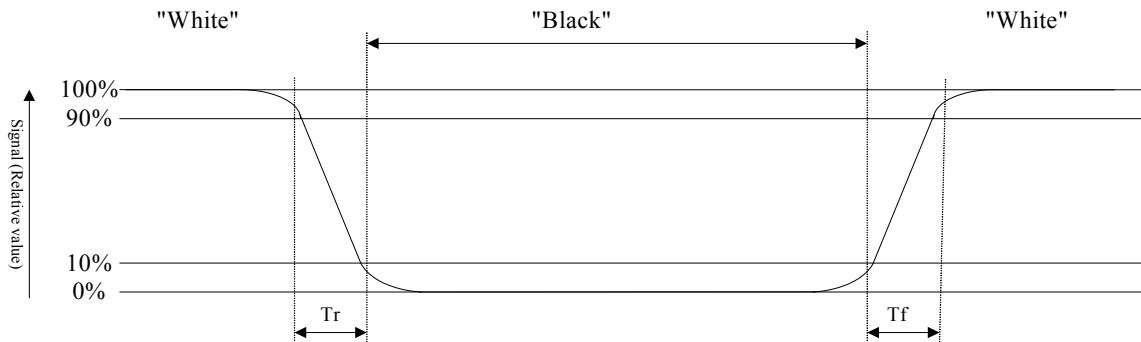

Normally Black

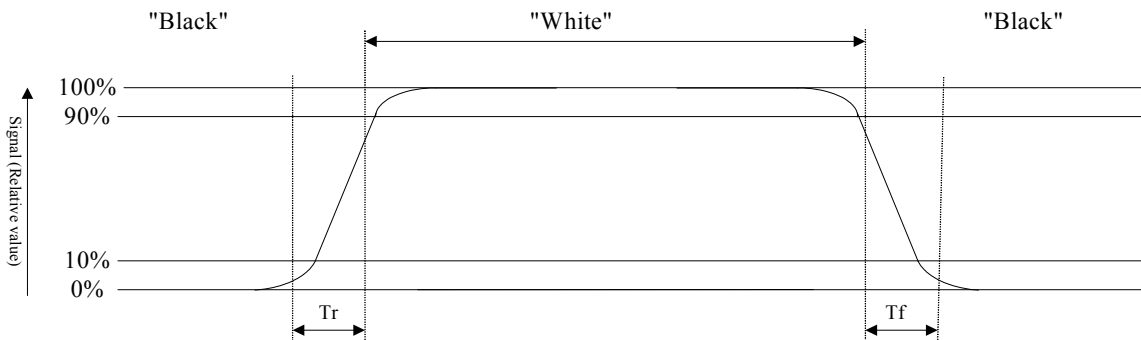

Note3: Definition of contrast ratio:

Contrast ratio is calculated with the following formula

Photo detector output when LCD is at “White” state

$$\text{Contrast ratio (CR)} = \frac{\text{Photo detector output when LCD is at "White" state}}{\text{Photo detector output when LCD is at "Black" state}}$$

Photo detector output when LCD is at “Black” state

Note4: Definition of viewing angle:

Refer to figure as below:

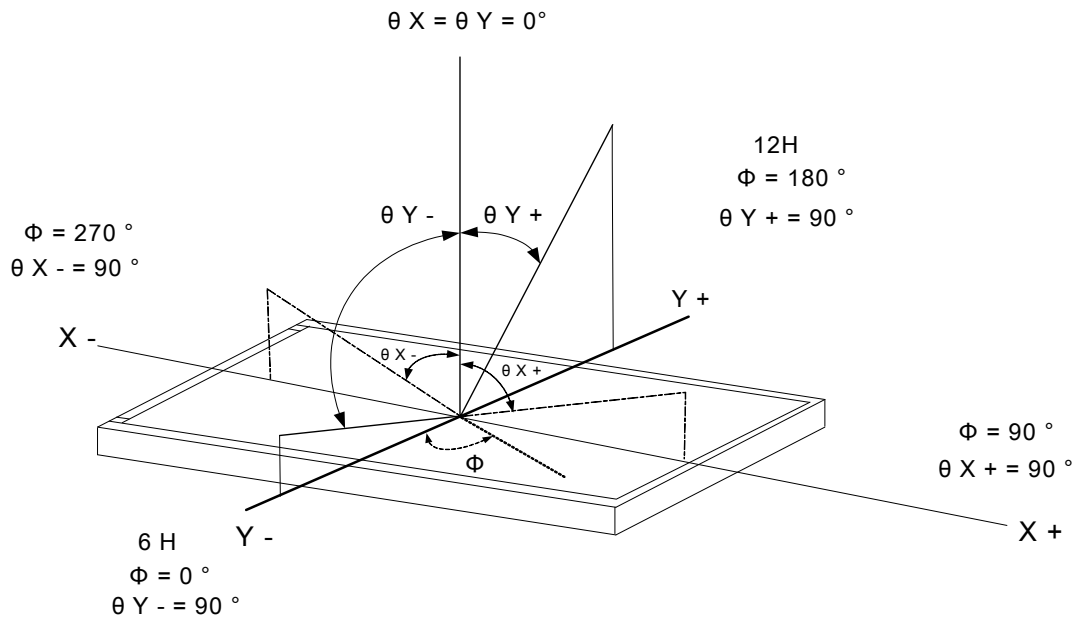



1.6 Backlight Characteristics

1.6.1 Backlight LED Driver IC (MP3362) Characteristics

Item	Symbol	Min.	Typ.	Max.	Unit
Led Driver Power Voltage	VLED	3.0	3.3	12	V
Led Driver Power Current	ILED	-	1.05	-	A
PWM Dimming Freq	FDIM	-	-	2	KHZ
EN threshold	EN ON	1.3	-	-	V
	EN OFF	-	-	0.4	V

1.6.2 Internal Backlight Electrical / Optical Characteristics

Item	Symbol	Conditions	Min.	Typ.	Max.	Unit
Forward Voltage	VF	IF=200mA	13.5	15	16.5	V
Average Brightness	IV		13000	15000	-	cd/m ²
CIE Color Coordinate	X		0.29	0.31	0.33	-
	Y		0.29	0.31	0.33	
Led lifetime				50k		
Color		White				

Circuit Diagram

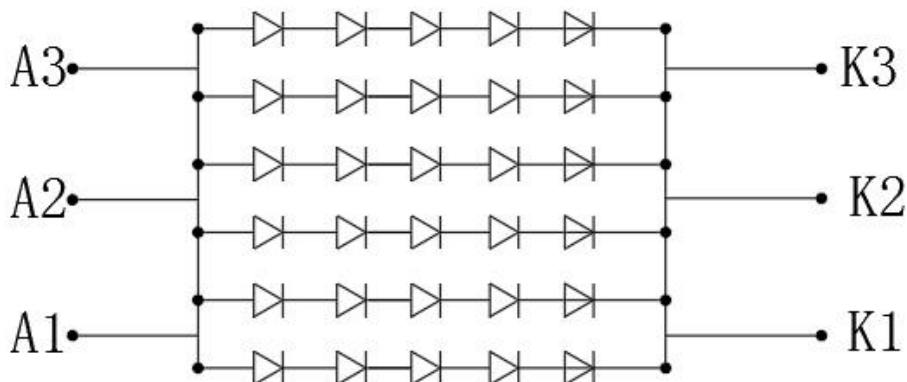



1.7 CTP Characteristics

Items.	Specification	Remark
Touch Panel Size	7 Inch	
Touch type	True Multi-touch with up to 5 Points of Absolution X and Y coordinates	
Input Method	VDD	
Structure type	G+G	
Interface	I ² C	
I2C address	0x55	
Operation Temperature	-30~80°C	
Storage Temperature	-30~80°C	
Control IC	ST1633i	
Transparency	≥86%	
Structure	Glass : T =1.1mm	
	Sensor: T =0.55mm	



1.8 EDID Characteristics

1.8.1 EEPROM Number :M24C02-RMN6TP

1.8.2 EEPROM Device Address 7bit :0X50

1.8.3 EEPROM Register Information:

Address	Description	Data	Name/Value(typ)	Notes
00h	No Data	00h	0	
01h	TFP-Interface	01h	DPI	1: DPI, 2: DSI
02h	CTP-Interface	01h	I2C	0: No CTP, 1: I2C
03h	Manufacturer	53h	S	SM: Smartwin (ASCII)
04h		57h	M	
05h		00h		
06h	Size	07h	7 inch	xx.xx inch
07h		00h		
08h	X-Res.(H-Byte)	04h	1024 px	
09h	X-Res.(L-Byte)	00h		
0Ah	Y-Res.(H-Byte)	02h	600px	
0Bh	Y-Res.(L-Byte)	58h		
0Ch	Pixel-Clock(typ.)	33h	51.2 MHz	xx.xx MHz
0Dh		02h		
0Eh	Color-Depth	18h	24 bit	
0Fh	HBP(H-Byte)	00h	160	
10h	HBP(L-Byte)	A0h		
11h	HPW	46h	70	
12h	HFP(H-Byte)	00h	160	
13h	HFP(L-Byte)	A0h		
14h	VBP(H-Byte)	00h	23	
15h	VBP(L-Byte)	17h		
16h	VPW	0Ah	10	
17h	VFP(H-Byte)	00h	12	
18h	VFP(L-Byte)	0Ch		
19h	Polarity_Mode	24h	00100100b	Bit0: H_sync_polarity Bit1: V_sync_polarity Bit2: DE_polarity (0: Negative, 1: Positive) Bit3: H_sync_phase(Reserve) Bit4: V_sync_phase(Reserve) Bit5: DE_phase (0: Rising edge, 1: Falling edge) Bit6: Pixel_invert Bit7: DE_mode (0: DE enabled, 1: Combined Sync)
1Ah	Rotation	00h	00000000b	Bit 0: Display Mirror X Bit 1: Display Mirror Y Bit 2: Display Sw ap X/Y Bit 3: Reserved, 0 Bit 4: Touch Mirror X Bit 5: Touch Mirror Y Bit 6: Touch Sw ap X/Y Bit 7: Reserved, 0
1Bh	Reserve	00h	0	
1Ch-FFh	No Data	00h	0	



2. MODULE STRUCTURE

2.1 Interface Pin Description Interface of TFT

Pin No.	Symbol	Description
1	GND	Ground
2	GND	Ground
3	GND	Ground
4	GND	Ground
5	+3V3 BKL	3.3V Power Input for BKL
6	+3V3 BKL	3.3V Power Input for BKL
7	+3V3 BKL	3.3V Power Input for BKL
8	+3V3 BKL	3.3V Power Input for BKL
9	PWM BKL	Back light PWM Control signal
10	+3V3 TFT	3.3V Power Input for TFT
11	GND	Ground
12	R0	Red data signal
13	R1	Red data signal
14	R2	Red data signal
15	R3	Red data signal
16	R4	Red data signal
17	R5	Red data signal
18	R6	Red data signal
19	R7	Red data signal
20	G0	Green data signal



21	G1	Green data signal
22	G2	Green data signal
23	G3	Green data signal
24	G4	Green data signal
25	G5	Green data signal
26	G6	Green data signal
27	G7	Green data signal
28	B0	Blue data signal
29	B1	Blue data signal
30	B2	Blue data signal
31	B3	Blue data signal
32	B4	Blue data signal
33	B5	Blue data signal
34	B6	Blue data signal
35	B7	Blue data signal
36	GND	Ground
37	VSYNC	Vertical Sync input for TTL mode.
38	HSYNC	Horizontal Sync input for TTL mode.
39	DE	Data input enable applied to the RGB



40	GND	Ground
41	PCLK	Clock signal for data latching and internal
42	GND	Ground
43	MODE(STDYB)	Standby mode, Normally pull high.
44	TFT_RESET	TFT Reset Pin
45	TP-RST	CTP Reset Pin
46	TP-INT	INT Output
47	TP-SDA/EEPROM-SDA	TP I2C Data/EEPROM I2C Data
48	TP-SCL/EEPROM-SCL	TP I2C Clock/EEPROM I2C Clock
49	+3V3 CTP	3.3V Power Input for CTP
50	GND	Ground

Recommended matched connector :DF23C-50DP-0.5V

Recommended driving boards:

- ESoPe :SLD_C_W_S3_BT817
- ESoPe :SLD_C_W_P4_C6

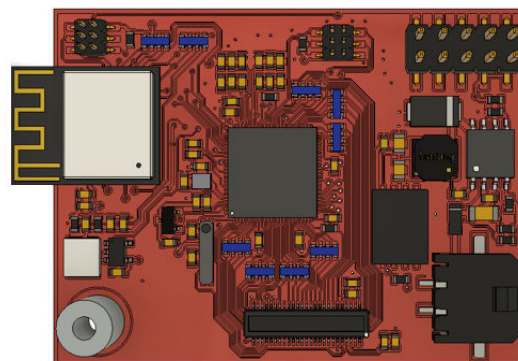
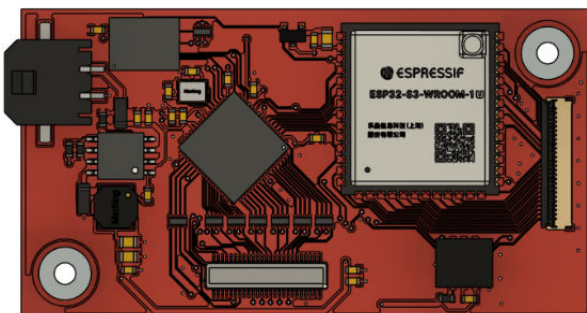



2.2 Timing Characteristics

2.2.1 Power-On/Off Timing Sequence



Power On/Off timing chart

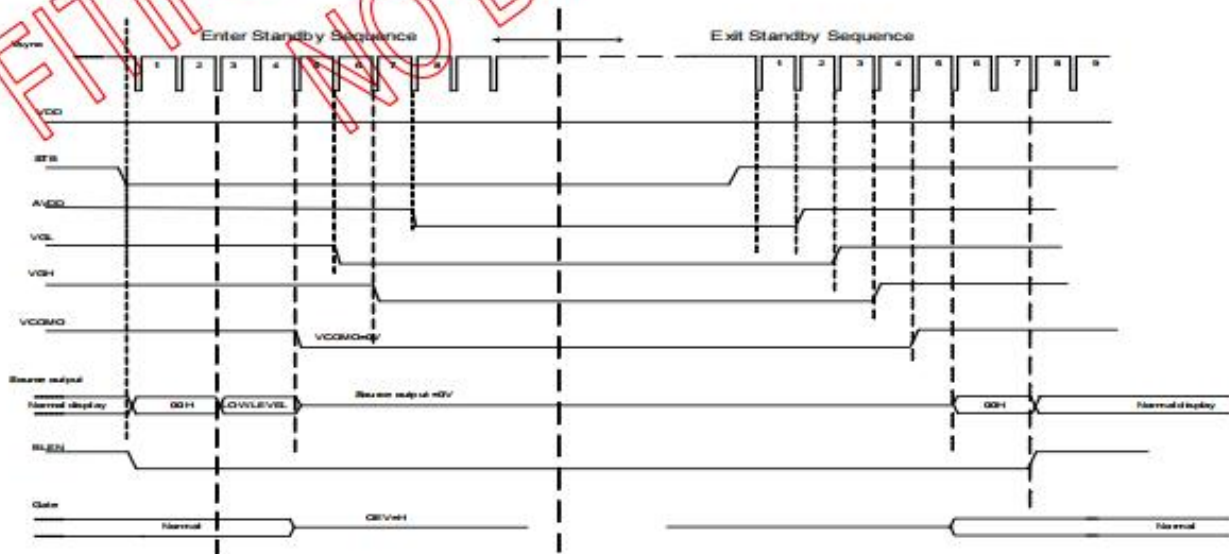

Enter and Exit Standby Mode timing chart

Note: Low level=3Fh, when NBW=L (Normally white)
Low level=00h, when NBW=H (Normally black)



2.2.2 Data Input Format for TTL

Vertical input timing

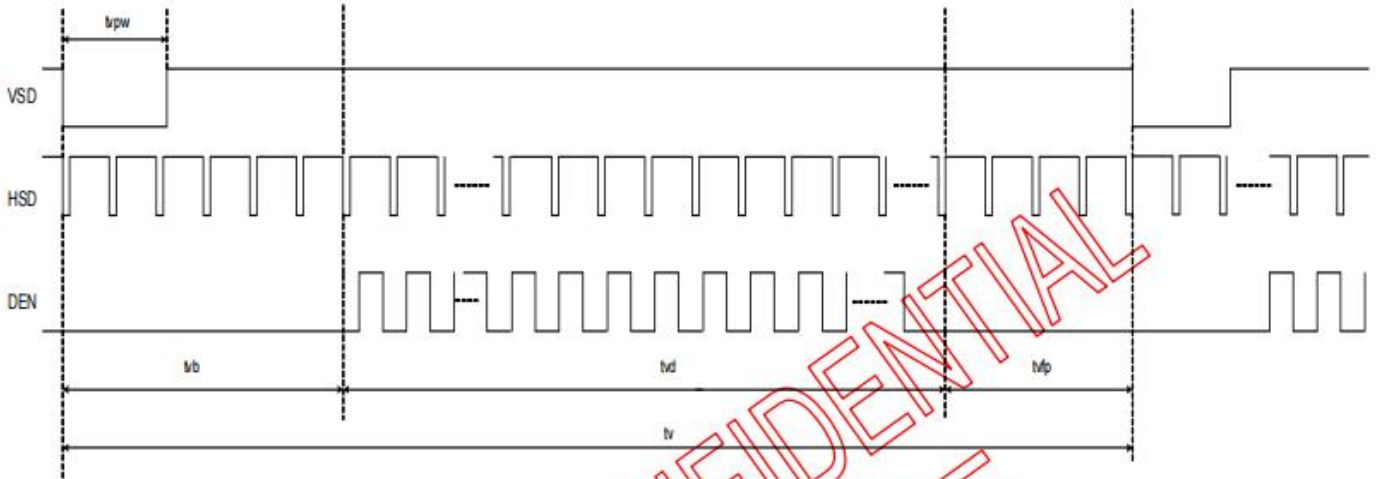

Vertical input timing

Horizontal input timing

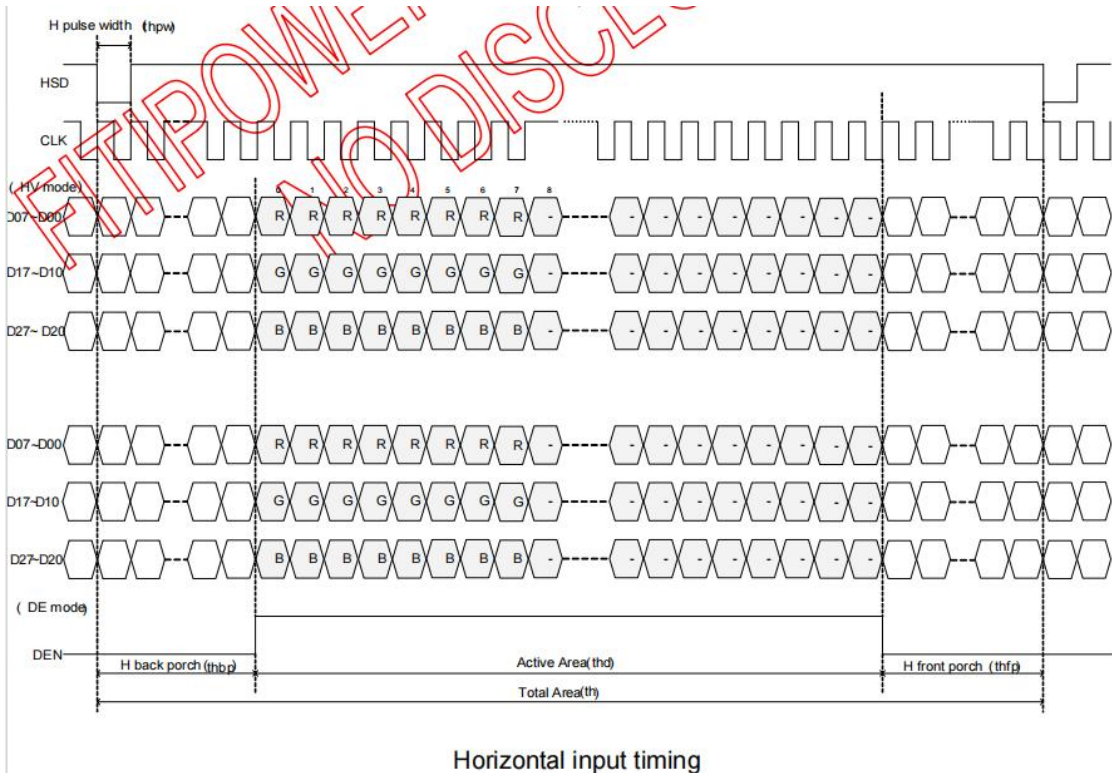

Horizontal input timing



2.2.3 Parallel RGB Timing Characteristic(1024*600)

DE mode

Parameter	Symbol	Value			Unit
		Min.	Typ.	Max.	
DCLK frequency @Frame rate=60hz	fclk	40.8	51.2	67.2	Mhz
Horizontal display area	thd	1024			DCLK
HSYNC period time	th	1114	1344	1400	DCLK
HSYNC blanking	thb+thfp	90	320	376	DCLK
Vertical display area	tvd	600			H
VSYNC period time	tv	610	635	800	H
VSYNC blanking	tvb+tvfp	10	35	200	H

HV mode(1)

HV mode Horizontal input timing					
Parameter	Symbol	Value			Unit
Horizontal display area	thd	1024			DCLK
DCLK frequency@ Frame rate=60hz	fclk	Min.	Typ.	Max.	Mhz
		44.9	51.2	63	
1 Horizontal Line	th	1200	1344	1400	DCLK
HSYNC pulse width	thpw	Min.	1		
		Typ.	-		
		Max.	140		
HSYNC back porch	thbp	160	160	160	
HSYNC front porch	thfp	16	160	216	

HV mode(2)

HV mode(2) Vertical input timing					
Parameter	Symbol	Value			Unit
		Min.	Typ.	Max.	
Vertical display area	tvd	600			H
VSYNC period time	tv	624	635	750	H
VSYNC pulse width	tpw	1	-	20	H
VSYNC back porch	tvb	23	23	23	H
VSYNC front porch	tvfp	1	12	127	H



2.2.4 AC Electrical Characteristics

TTL mode

Parameter	Symbol	Condition	Min.	Typ.	Max.	Unit
VDD Power On Slew rate	TPOR	From 0V to 90% VDD	1	-	20	ms
RST pulse width	TRST	DCLK = 65MHz	50	-	-	us
DCLK cycle time	Tcph	-	14	-	-	ns
DCLK pulse duty	Towh	-	40	50	60	%
VSD setup time	Tvst	-	5	-	-	ns
VSD hold time	Tvhd	-	5	-	-	ns
HSD setup time	Thst	-	5	-	-	ns
HSD hold time	Thhd	-	5	-	-	ns
Data set-up time	Tdsu	D0[7:0], D1[7:0], D2[7:0] to DCLK	5	-	-	ns
Data hold time	Tdhd	D0[7:0], D1[7:0], D2[7:0] to DCLK	5	-	-	ns
DE setup time	Tesu	-	5	-	-	ns
DE hold time	Tehd	-	5	-	-	ns
Output stable time	Tsst	Dual gate	-	-	3	us

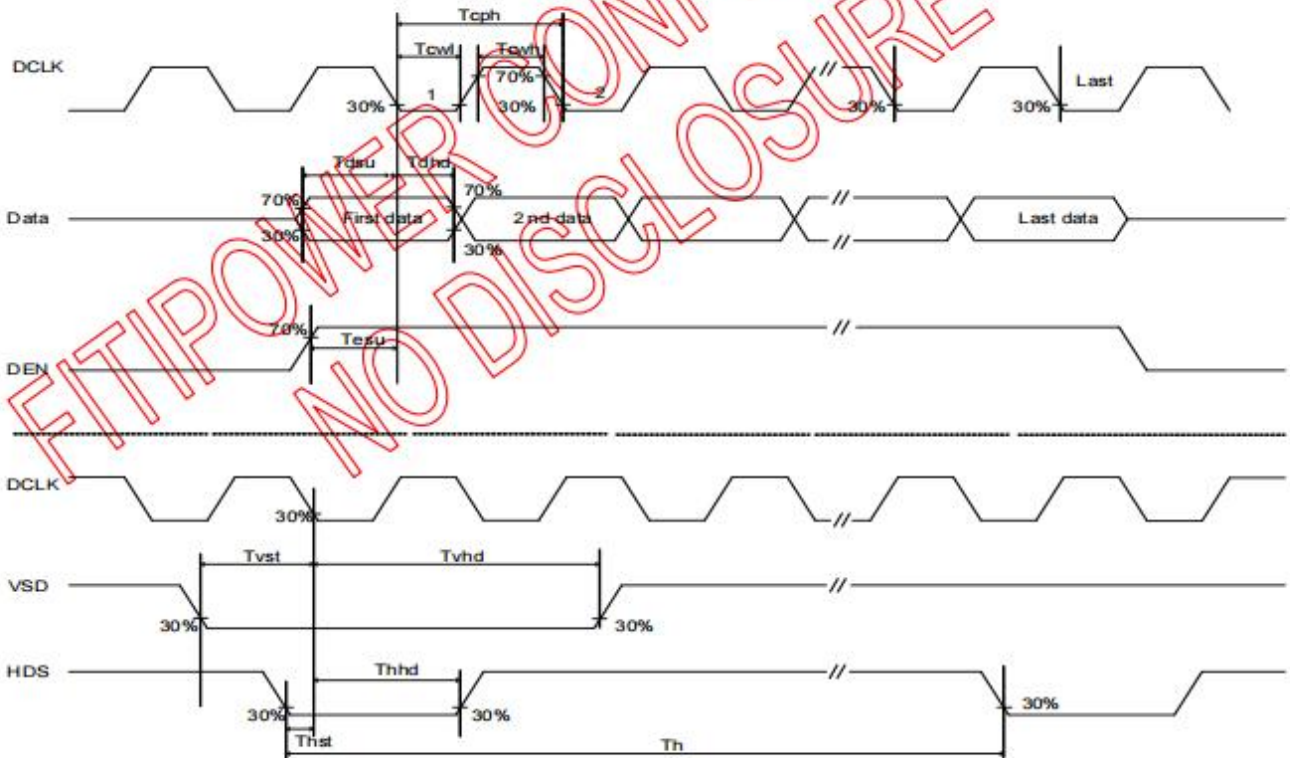

Parallel Input Clock and Data timing



3. Inspection Specification

- ◆Scope : The document shall be applied to TFT-LCD Module for 0.96" ~12.3" (Ver.A01).
- ◆Inspection Standard : MIL-STD-105E Table Normal Inspection Single Sampling Level II.
- ◆Equipment : Gauge 、 MIL-STD 、 SmartWin Tester 、 Sample
- ◆Defect Level : Major Defect AQL : 0.65 ; Minor Defect AQL : 1.5
- ◆OUT Going Defect Level : Sampling.
- ◆Standard of the product appearance test :

a. Manner of appearance test :

- (1). The test best be under 20W×2 fluorescent light(about 300lux ~500lux)
， and distance of view must be at 30~40 cm.
- (2). The test direction is base on about around 45° of vertical line.

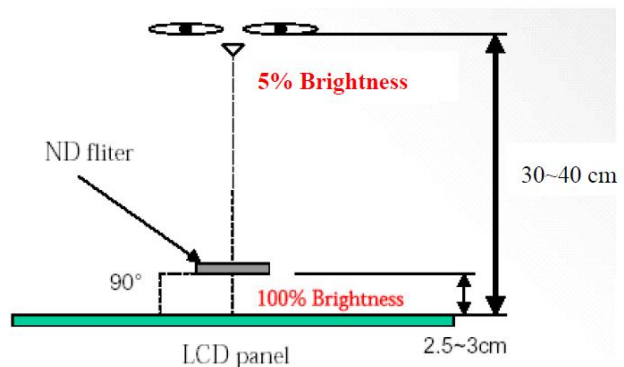
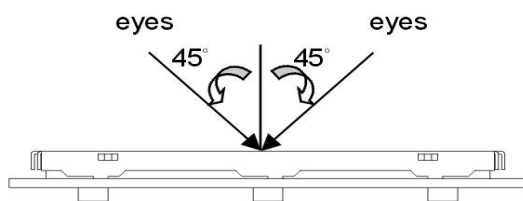

(3). Definition of area.

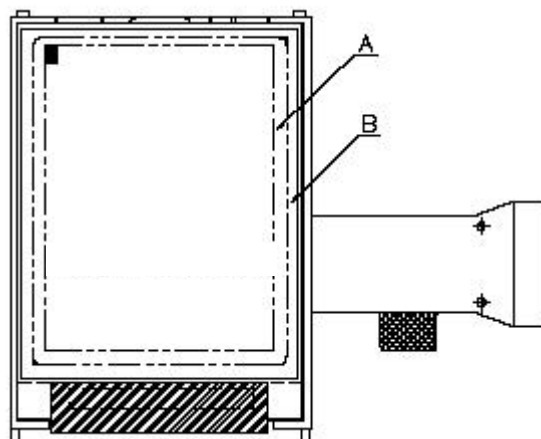

A area : viewing area

B area : Outside of viewing area

(4). Standard of inspection : (Unit : mm)



3.1 Major defect

Item No	Items to be inspected	Inspection Standard
3.1.1	All functional defects	1) No display 2) Display abnormally 3) Short circuit 4) line defect
3.1.2	Missing	Missing function component
3.1.3	Crack	Glass Crack

3.2 Minor defect

Item No	Items to be inspected	Inspection Standard	
3.2.1	Polarizer dirt and spot	For dark/white spot is defined	
		$\varphi = (x+y) / 2$	
		Size φ (mm)	Acceptable Quantity
		$\varphi \leq 0.15$	Ignore
		$0.15 < \varphi \leq 0.50$	2
$0.50 < \varphi$	0		

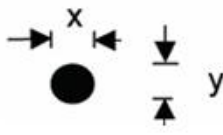
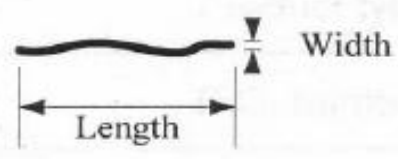

Item No	Items to be inspected	Inspection Standard	
3.2.2	Panel dirt and spot	For dark/white spot is defined $\varphi = (x+y) / 2$ 	
		Size φ (mm)	Acceptable Quantity
		$\varphi \leq 0.10$	Ignore
		$0.10 < \varphi \leq 0.25$	3
		$0.25 < \varphi$	Not allowed
3.2.3	Line Defect Including Black line White line Scratch	Define: 	
		Width(mm) Length(mm)	Acceptable Quantity
		$W \leq 0.03$	Ignore
		$0.03 < W \leq 0.07$ $L \leq 5.0$	3
		$W > 0.07$	As round type



3.2.4	Polarizer Dent/Bubble	Size φ (mm)		Acceptable Quantity
		$\varphi \leq 0.15$		Ignore
		$0.15 < \varphi \leq 0.50$		2
		$0.50 < \varphi$		0
3.2.5	Electrical Dot Defect	Item		Acceptance (Q'ty)
		Dot Defect	Bright dot	≤ 4
			Dark dot	≤ 4
<p>Inspection pattern: full white, full black, Red, Green and blue screens. It is defined as dot defect if defect area $> 1/2$ dot. The distance between two dot defect ≥ 5 mm. Bright dot that can not be seen through 2% ND filter.</p>				
3.2.6	Mura	Visible through ND5% at fullblack pattern is not allowed		



- Note:
1. Dot defect is defined as the defective area of the dot area is larger than 50% of the dot area.
 2. The distance between two bright dot defects (red, green, blue, and white) should be larger than 5mm.
 3. The distance between black dot defects or black and bright dot defects should be more than 5mm apart.

4. The definitions of the inner display area

And outer display area

I: Inner display area

O: Outer display area

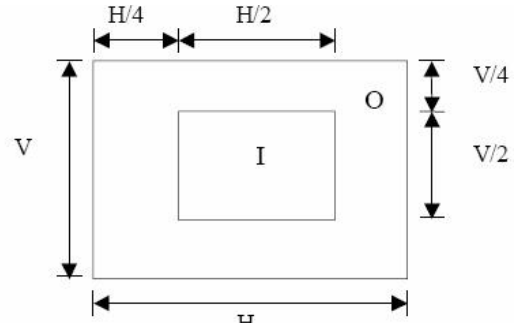

5. Polarizer bubble is defined as the bubble appears on active display area. The defect of polarizer bubble shall be ignored if the polarizer bubble appears on the outside of active display area.



5. PRECAUTION RELATING PRODUCT HANDLING

5.1 SAFETY

- 5.1.1 If the LCD panel breaks , be careful not to get the liquid crystal to touch your skin.
- 5.1.2 If the liquid crystal touches your skin or clothes , please wash it off immediately by using soap and water.

5.2 HANDLING

- 5.2.1 Avoid any strong mechanical shock which can break the glass.
- 5.2.2 Avoid static electricity which can damage the CMOS LSI—When working with the module , be sure to ground your body and any electrical equipment you may be using.
- 5.2.3 Do not remove the panel or frame from the module.
- 5.2.4 The polarizing plate of the display is very fragile. So , please handle it very carefully ,do not touch , push or rub the exposed polarizing with anything harder than an HB pencil lead (glass , tweezers , etc.)
- 5.2.5 Do not wipe the polarizing plate with a dry cloth , as it may easily scratch the surface of plate.
- 5.2.6 Do not touch the display area with bare hands , this will stain the display area.
- 5.2.7 Do not use ketonics solvent & aromatic solvent. Use with a soft cloth soaked with a cleaning naphtha solvent.
- 5.2.8 To control temperature and time of soldering is $320\pm 10^{\circ}\text{C}$ and 3-5 sec.
- 5.2.9 To avoid liquid (include organic solvent) stained on LCM .
- 5.2.10 Caution!(LCM with Capacitive Touch Panel)Strong EMI-sources such as switch-mode power supplies (SMPS) can lead to touch malfunction (e.g. ghost-touches).Therefore, the touch needs to be thoroughly tested inside the target application.

5.3 STORAGE

- 5.3.1 Store the panel or module in a dark place where the temperature is $25^{\circ}\text{C} \pm 5^{\circ}\text{C}$ and the humidity is below 65% RH.
- 5.3.2 Do not place the module near organics solvents or corrosive gases.
- 5.3.3 Do not crush , shake , or jolt the module.

5.4 TERMS OF WARRANTY

- 5.4.1 Applicable warrant period
The period is within thirteen months since the date of shipping out under normal using and storage conditions.
- 5.4.2 Unaccepted responsibility
This product has been manufactured to your company's specification as a part for use in your company's general electronic products. It is guaranteed to perform according to delivery specifications. For any other use apart from general electronic equipment , we cannot take responsibility if the product is used in nuclear power control equipment , aerospace equipment , fire and security systems or any other applications in which there is a direct risk to human life and where extremely high levels of reliability are required.

REV	REVISION RECORD	DATE
△	New drawing	2024-12-03
△	Add Edging Tape	2025-01-13

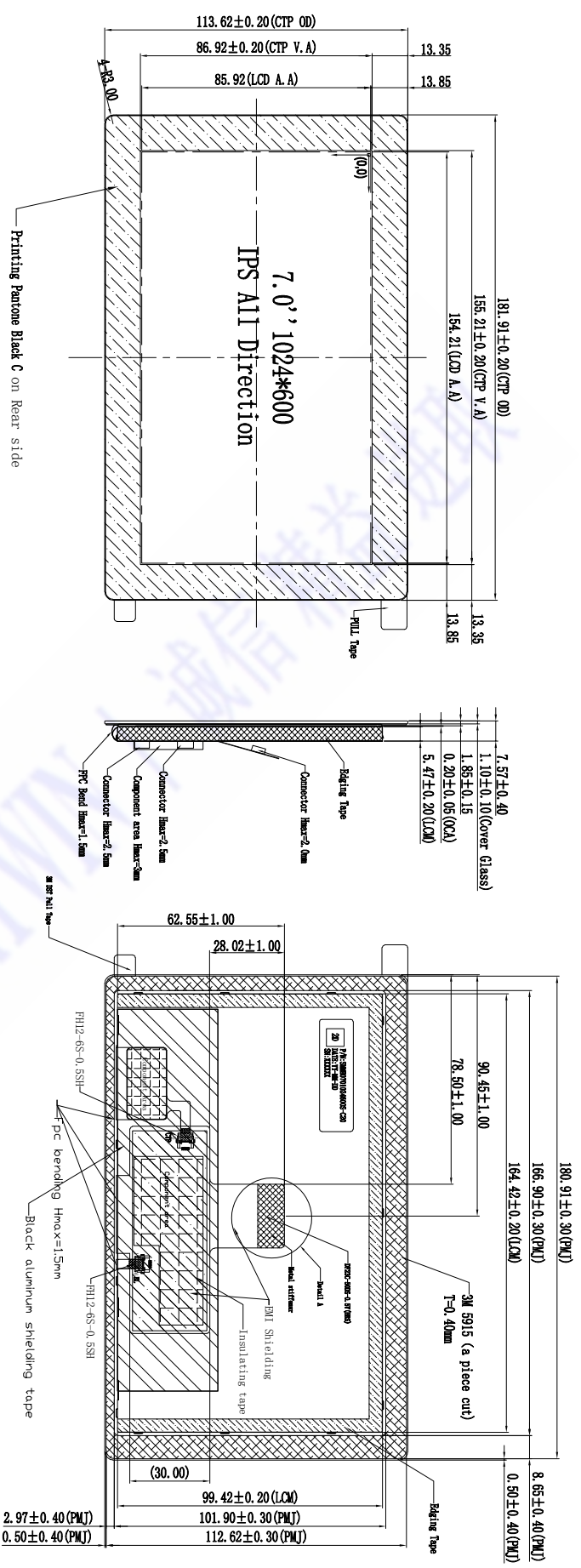

- CTP Technical parameter
- COVER GLASS+SENSOR+FPC G+G 总厚度: 1.85±0.15mm;
 - OPERATING VOLTAGE:11C : VDD 3.3V;
 - Transmittance: ≥86%
 - Surface hardness: ≥6H
 - Undeclared tolerance: ±0.2
 - OPERATING TEMPERATURE: -30°C~+80°C, ≤80%RH
 - STORAGE TEMPERATURE: -30°C~+80°C, ≤85%RH
 - ROHS
 - Glass porometer: (CS) = 500MPa, DOL > 10um,
- Note: CNI Recommended Matched connector DF23C-50DP-0.5V (HRS)

CONFIRM ALL TYPE DRAWINGS OF THIS AND PASS BACK!

OPERATING VOLTAGE: 3.3V	OPERATING CURRENT: --
DISPLAY TYPE: Normally black	VIEW DIRECTION: Free
LCD Resolution: 1024 (H) RGB X 600 (V)	CTP Interface: I ² C
LCD CONTROLLER: BK79001+BK73215	CTP CONTROLLER: ST16331
BACK LIGHT: If=200mA, Vf=15V (typ)	
OPERATING TEMPERATURE: -30°C TO 80°C (240hrs)	STORAGE TEMPERATURE: -30°C TO 80°C (240hrs)
DEFAULT TOLERANCE: ±0.2	ROHS STANDARD: YES

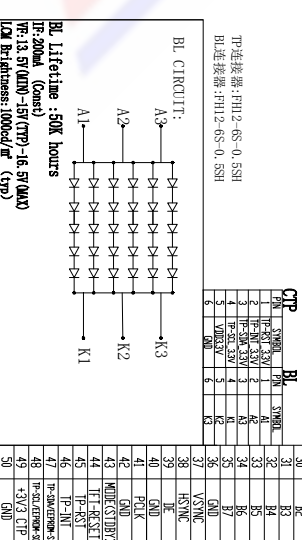
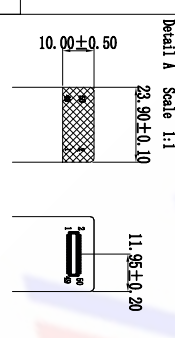

		江苏奥威电子科技有限公司 JIANGSU SMARTWIN ELECTRONICS TECHNOLOGY Co., LTD	
TITLE	模块外形图	CUSTOMER NUMBER	-
DES' D BY	朱海	PRODUCT MODEL	SMH0701024600S-C20-WX
CHK' D BY		SERIAL NUMBER	
APPROVED		SCALE	1:1
REV		UNIT	mm
DATE	2025-01-13		
NO.	1/1		