



SPECIFICATIONS

CUSTOMER	:	SCHUKAT
MASS PRODUCTION CODE	:	SMMT024240320H-A13
SAMPLE VERSION	:	01
SPECIFICATIONS EDITION	:	001
DRAWING NO. (Ver.)	:	SMMT024240320H-A13-WX-A

Customer Approved

Date:

Approved	Checked	Designer
 罗潇	闫伟	陈恩添

- Preliminary specification for design input
- Specification for sample approval



Contents

1. SPECIFICATIONS

- 1.1 Features
- 1.2 Mechanical Specifications
- 1.3 Absolute Maximum Ratings
- 1.4 DC Electrical Characteristics
- 1.5 Optical Characteristics
- 1.6 Backlight Characteristics
- 1.7 EEPROM Information

2. MODULE STRUCTURE

- 2.1 Interface Pin Description
- 2.2 Timing Characteristics

3. Inspection Specification

- 2.1 Major defect
- 2.2 Minor defect

4. RELIABILITY TEST

- 4.1 Reliability Test Condition

5. PRECAUTION RELATING PRODUCT HANDLING

Appendix : 1. LCM Drawing

Note : For detailed information please refer to IC data sheet :

Primacy(TFT LCD):ST7789T3



1 .SPECIFICATIONS

1.1 Features

Item	Standard Value
Display Type	240RGB(H)x320(V)
LCD Type	Normally black, Transmissive
Screen size(inch)	2.4 inch
Viewing Direction	Free
Interface	RGB-16Bit
Other(controller/driver IC)	ST7789T3

1.2 Mechanical Specifications

Module

Item	Standard Value	Unit
Outline Dimension	57(W) ×40.44(L) ×2.20(H)	mm

TFT LCD

Item	Standard Value	Unit
Active Area	48.96(W)x36.72(L)	mm



1.3 Absolute Maximum Ratings

Module

Item	Symbol	Condition	Min.	Typ.	Max.	Unit
Operating Temperature	T _{OP}	-	-30	-	80	°C
Storage Temperature	T _{ST}	-	-30	-	80	°C

1.4 DC Electrical Characteristics

Module

GND = 0V, Ta = 25°C

Item	Symbol	Condition	Min.	Typ.	Max.	Unit
Power Supply Voltage	VDD	Operating voltage	3.0	3.3	3.6	V
Input H/L Level Voltage	VIH	-	0.7VDDI	-	VDDI	V
	VIL	-	VSS	-	0.3VDDI	V
Output H/L Level Voltage	VOH	-	0.8VDDI	-	VDDI	V
	VOL	-	VSS	-	0.2VDDI	V
Supply Current	IDD	VDD = 3.3 V	-	15	22.5	mA



1.5 Optical Characteristics

TFT LCD Module

VDD= 3.3V, Ta=25°C

Item		Symbol	Condition	Min.	Typ.	Max.	unit	-
Response time	Tr+Tf	25°C	-	-	35	40	ms	-
Viewing angle	Top	θY+	CR ≥ 10	80	85	-	Deg.	Note 4
	Bottom	θY-		80	85	-		
	Left	θX-		80	85	-		
	Right	θX+		80	85	-		
Contrast ratio		CR	Θ=0°	900	1200	-	-	Note 3
Color of CIE Coordinate (B/L & LCD)	White	X	IF=40mA	-0.05	0.313	+0.05	-	Note1
		Y			0.360			
	Red	X			0.635			
		Y			0.366			
	Green	X			0.328			
		Y			0.642			
	Blue	X			0.135			
		Y			0.095			
Average Brightness Pattern=white display (B/L & LCD)*1		IV	IF= 40mA	900	1100	-	cd/m2	Note1
Uniformity (B/L & LCD)*2		ΔB	-	75	-	-	%	Note1

Note 1:

*1 : $\Delta B = B(\min) / B(\max) * 100\%$

*2 : Measurement Condition for Optical Characteristics:

a : Environment: 25°C±5°C / 60±20%R.H , no wind , dark room below 10 Lux at typical lamp current and typical operating frequency.

b : Measurement Distance: 500 ± 50 mm , (θ= 0°)

c : Equipment: TOPCON BM-7 fast , (field 1°) , after 10 minutes operation.

d : The uncertainty of the C.I.E coordinate measurement ±0.01 , Average Brightness ± 4%

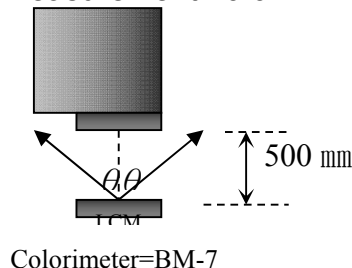
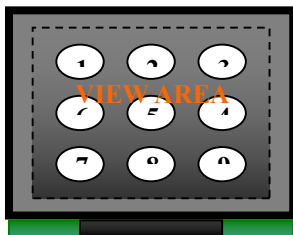



To be measured at the center area of panel with a viewing cone of 1° by Topcon luminance meter BM-7, after 10 minutes operation (module)

Note2: Definition of response time:

The output signals of photo detector are measured when the input signals are changed from “black” to “white”(falling time) and from “white” to “black”(rising time), respectively. The response time is defined as the time interval between the 10% and 90% of Amplitudes.

Refer to figure as below:

Normally White

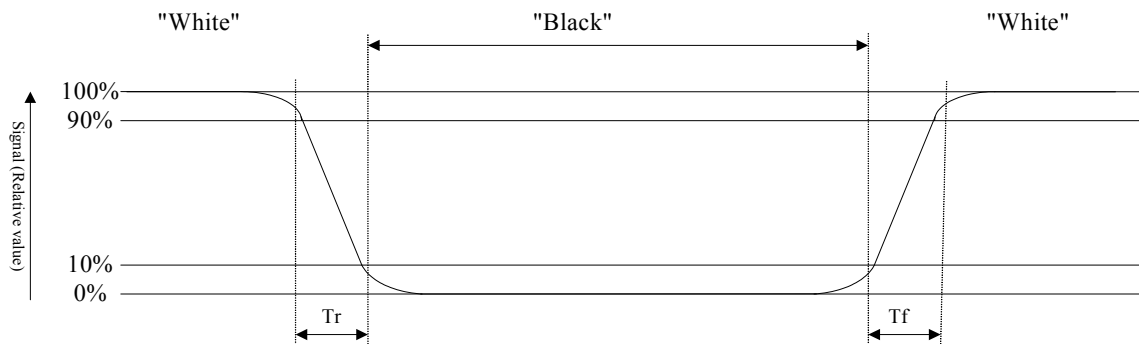

Normally Black

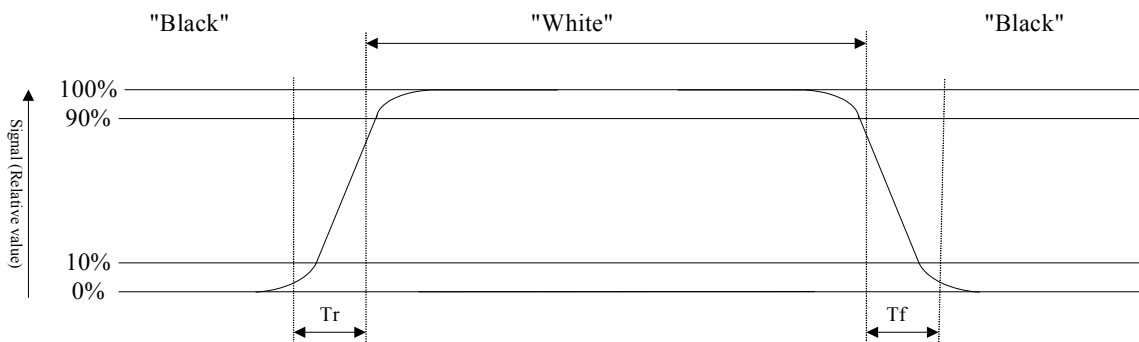

Note3: Definition of contrast ratio:

Contrast ratio is calculated with the following formula

Photo detector output when LCD is at “White” state

Contrast ratio (CR) = $\frac{\text{Photo detector output when LCD is at “White” state}}{\text{Photo detector output when LCD is at “Black” state}}$

Photo detector output when LCD is at “Black” state

Note4: Definition of viewing angle:

Refer to figure as below:

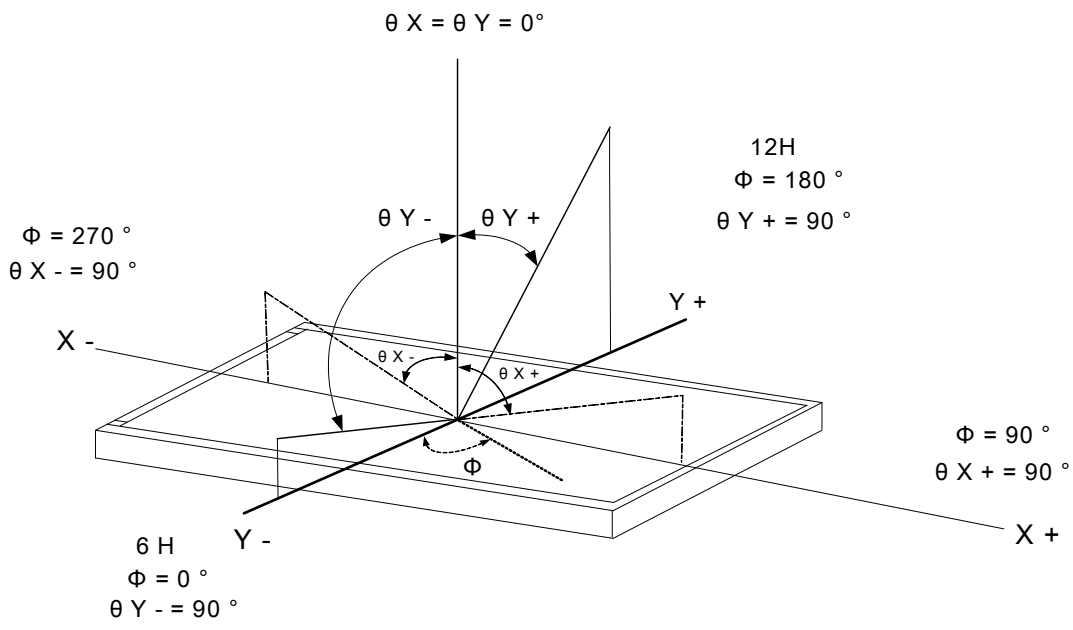



1.6 Backlight Characteristics

1.6.1 Backlight LED Driver IC (RT9293) Characteristics

Item	Symbol	Min.	Typ.	Max.	Unit
Led Driver Power Voltage	VLED	2.5	3.3	5.5	V
Led Driver Power Current	ILED	-	0.14	-	A
PWM Dimming Freq	FDIM	-	-	2	KHZ
EN threshold	EN ON	1.3	-	-	V
	EN OFF	-	-	0.4	V

1.6.2 INTERNAL Backlight Electrical / Optical Characteristics

Item	Symbol	Conditions	Min.	Typ.	Max.	Unit
Forward Voltage	VF	IF=40mA	8.1	9.0	9.9	V
Average Brightness	IV		19000	20000	-	cd/m ²
CIE Color Coordinate	X		0.25	0.28	0.31	-
	Y		0.26	0.29	0.32	
Led lifetime					50k	
Color		White				

1.6.3 Circuit Diagram

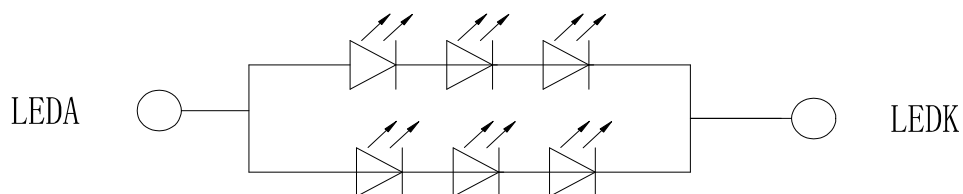



1.7 EEPROM Information

1.7.1 EEPROM Number :M24C02-RMN6TP

1.7.2 EEPROM Device Address 7bit :0X50

1.7.3 EEPROM Register Information:

Address	Description	Data	Name/Value(typ.)	Notes
00h	No Data	00h	0	
01h	TFP-Interface	01h	DPI	1: DPI, 2: DSI
02h	CTP-Interface	00h	No CTP	0: No CTP, 1: I2C
03h	Manufacturer	53h	S	SM: Smartwin (ASCII)
04h		57h	M	
05h		00h		
06h	Size	02h	2.4 inch	xx.xx inch
07h		04h		
08h	X-Res.(H-Byte)	00h	240 px	
09h	X-Res.(L-Byte)	F0h		
0Ah	Y-Res.(H-Byte)	01h	320px	
0Bh	Y-Res.(L-Byte)	40h		
0Ch	Pixel-Clock(typ.)	07h	7.0 MHz	xx.xx MHz
0Dh		00h		
0Eh	Color-Depth	10h	16 bit	
0Fh	HBP(H-Byte)	00h	10	
10h	HBP(L-Byte)	0Ah		
11h	HPW	0Ah	10	
12h	HFP(H-Byte)	00h	38	
13h	HFP(L-Byte)	26h		
14h	VBP(H-Byte)	00h	4	
15h	VBP(L-Byte)	04h		
16h	VPW	04h	4	
17h	VFP(H-Byte)	00h	8	
18h	VFP(L-Byte)	08h		



19h	Polarity_Mode	24h	00100100b	<p>Bit0: H_sync_polarity Bit1: V_sync_polarity Bit2: DE_polarity (0: Negative, 1: Positive)</p> <p>Bit3: H_sync _phase(Reserve) Bit4: V_sync _phase(Reserve) Bit5: DE_phase (0: Rising edge, 1: Falling edge)</p> <p>Bit6: Pixel_invert</p> <p>Bit7: DE_mode (0: DE enabled,1: Combined Sync)</p>
1Ah	Rotation	05h	00000101b	<p>Bit 0: Display Mirror X Bit 1: Display Mirror Y Bit 2: Display Swap X/Y Bit 3: Reserved, 0 Bit 4: Touch Mirror X Bit 5: Touch Mirror Y Bit 6: Touch Swap X/Y Bit 7: Reserved, 0</p>
1Bh	Reserve	00h	0	
1Ch-FFh	No Data	00h	0	



2.MODULE STRUCTURE

2.1 Interface Pin Description

Interface of TFT

Pin No.	Symbol	Function
1	GND	Ground
2	GND	Ground
3	GND	Ground
4	GND	Ground
5	+3V3 BKL	3.3V Power Input for BKL
6	+3V3 BKL	3.3V Power Input for BKL
7	+3V3 BKL	3.3V Power Input for BKL
8	+3V3 BKL	3.3V Power Input for BKL
9	PWM BKL	Back light PWM Control signal
10	+3V3 TFT	3.3V Power Input for TFT
11	GND	Ground
12	GND	Ground
13	GND	Ground
14	GND	Ground
15	R0	Red data signal
16	R1	Red data signal
17	R2	Red data signal
18	R3	Red data signal
19	R4	Red data signal
20	GND	Ground
21	GND	Ground
22	G0	Green data signal
23	G1	Green data signal
24	G2	Green data signal
25	G3	Green data signal



26	G4	Green data signal
27	G5	Green data signal
28	GND	Ground
29	GND	Ground
30	GND	Ground
31	B0	Blue data signal
32	B1	Blue data signal
33	B2	Blue data signal
34	B3	Blue data signal
35	B4	Blue data signal
36	GND	Ground
37	VSYNC	Vertical Sync input for TTL mode.
38	HSYNC	Horizontal Sync input for TTL mode.
39	DE	Data input enable applied to the RGB.
40	GND	Ground
41	PCLK	Clock signal for data latching and internal
42	GND	Ground
43	MODE(STDYB)	Standby mode, Normally pull high.
44	TFT-RESET	TFT Reset Pin.
45	NC	No Connected
46	NC	No Connected
47	I2C_SDA EEPROM	EEPROM I2C Data
48	I2C_SDA EEPROM	EEPROM I2C Clock
49	3V3_EEPROM	3.3V Power Input for EEPROM
50	GND	Ground



Recommended matched connector :DF23C-50DP-0.5V

Recommended driving boards:

- ESoPe :SLD_C_W_S3
- ESoPe :SLD_C_W_P4_C6

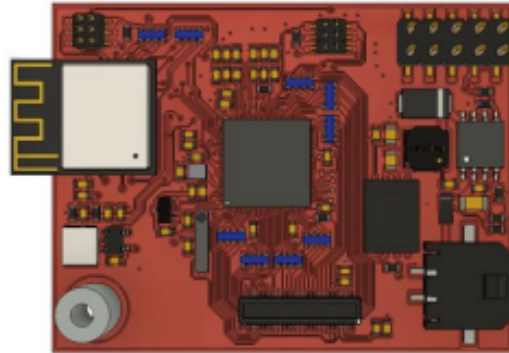



2.2 Timing Characteristics

2.2.1 Power-On/Off Timing Sequence

The power on/off sequence is illustrated below

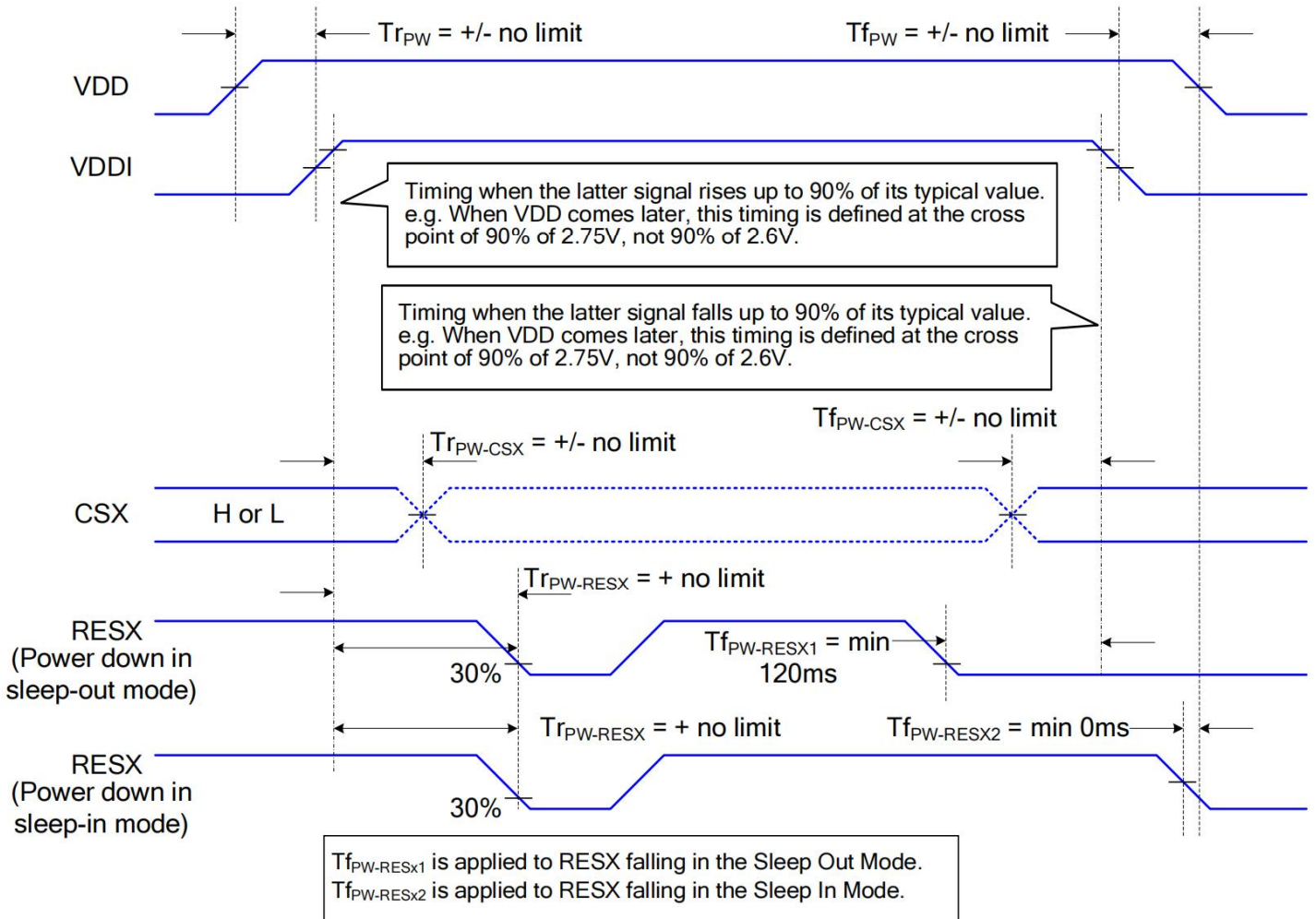



2.2.2 Parallel RGB Timing Characteristic:

The timing chart of RGB interface DE mode is shown as follows.

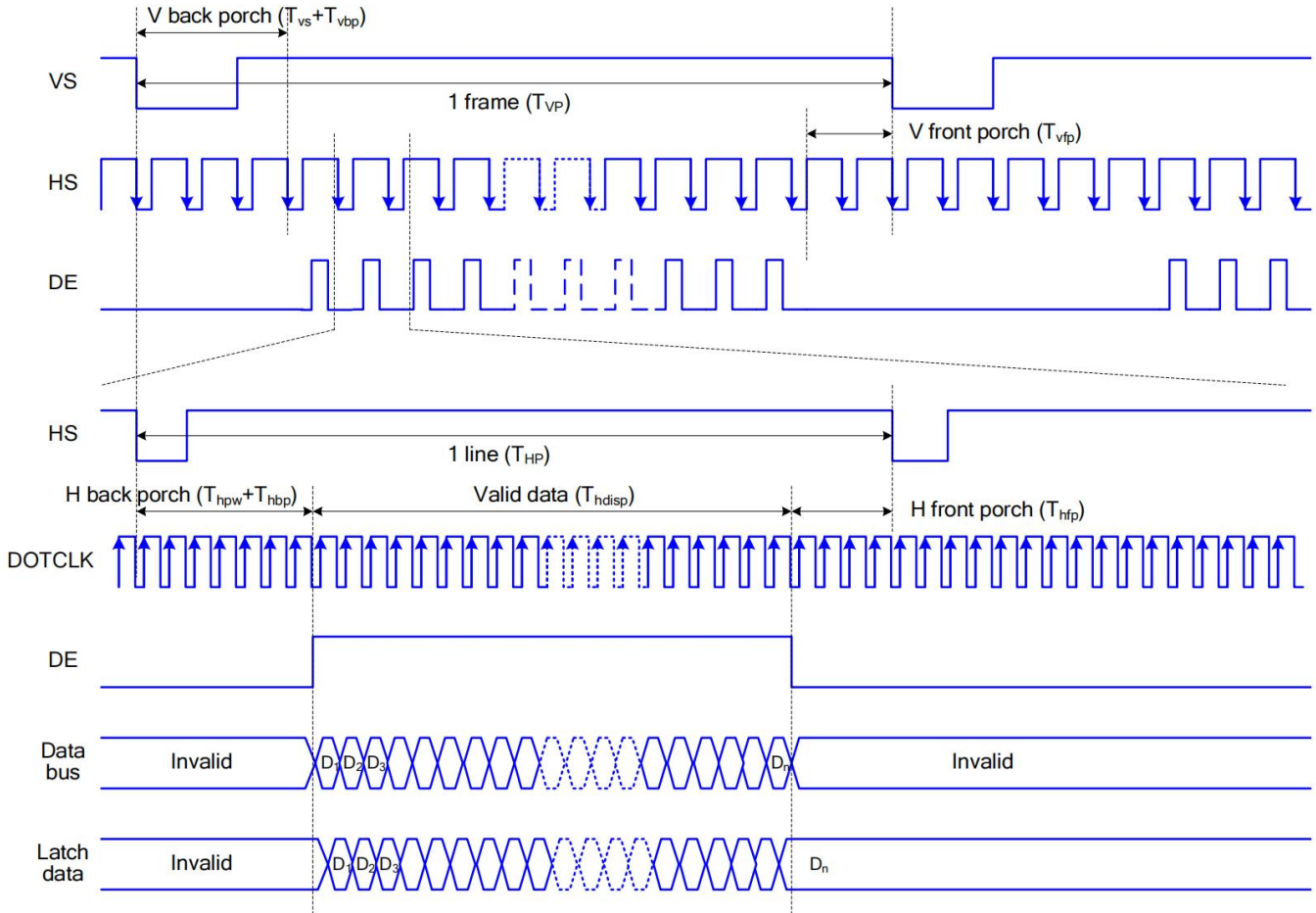

Note: The setting of front porch and back porch in host must match that in IC as this mode.



The timing chart of RGB interface HV mode is shown as follows.

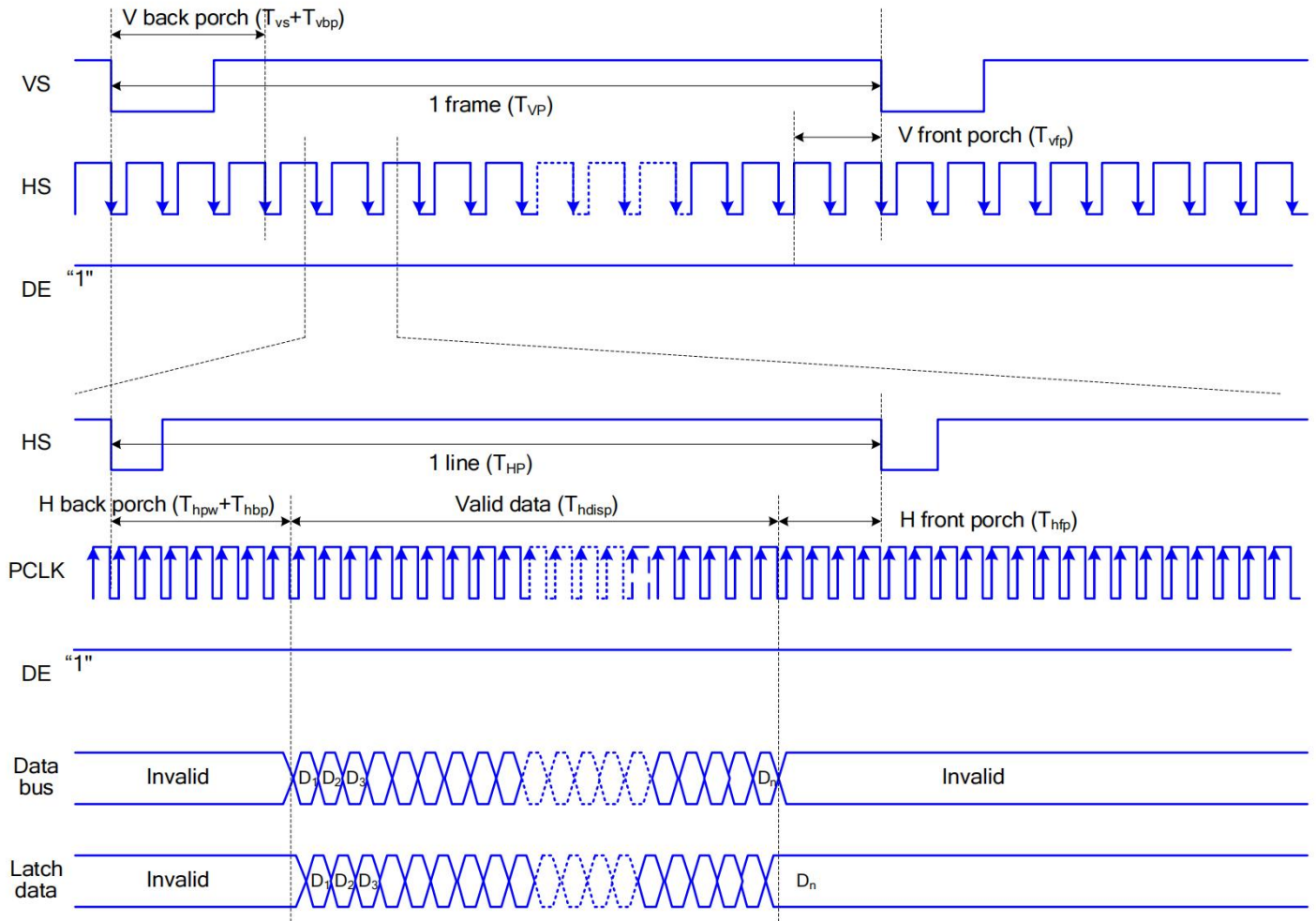

Parameter	Symbol	Min.	Typ.	Max.	Unit
Horizontal Sync. Width	hpw	2	10	hpw+hbp=31	Clock
Horizontal Sync. Back Porch	hbp	4	10		Clock
Horizontal Sync. Front Porch	hfp	2	38	-	Clock
Vertical Sync. Width	vs	1	4	vs+vbp=127	Line
Vertical Sync. Back Porch	vbp	1	4		Line
Vertical Sync. Front Porch	vfp	1	8	-	Line



2.2.3 RGB Interface Characteristics:

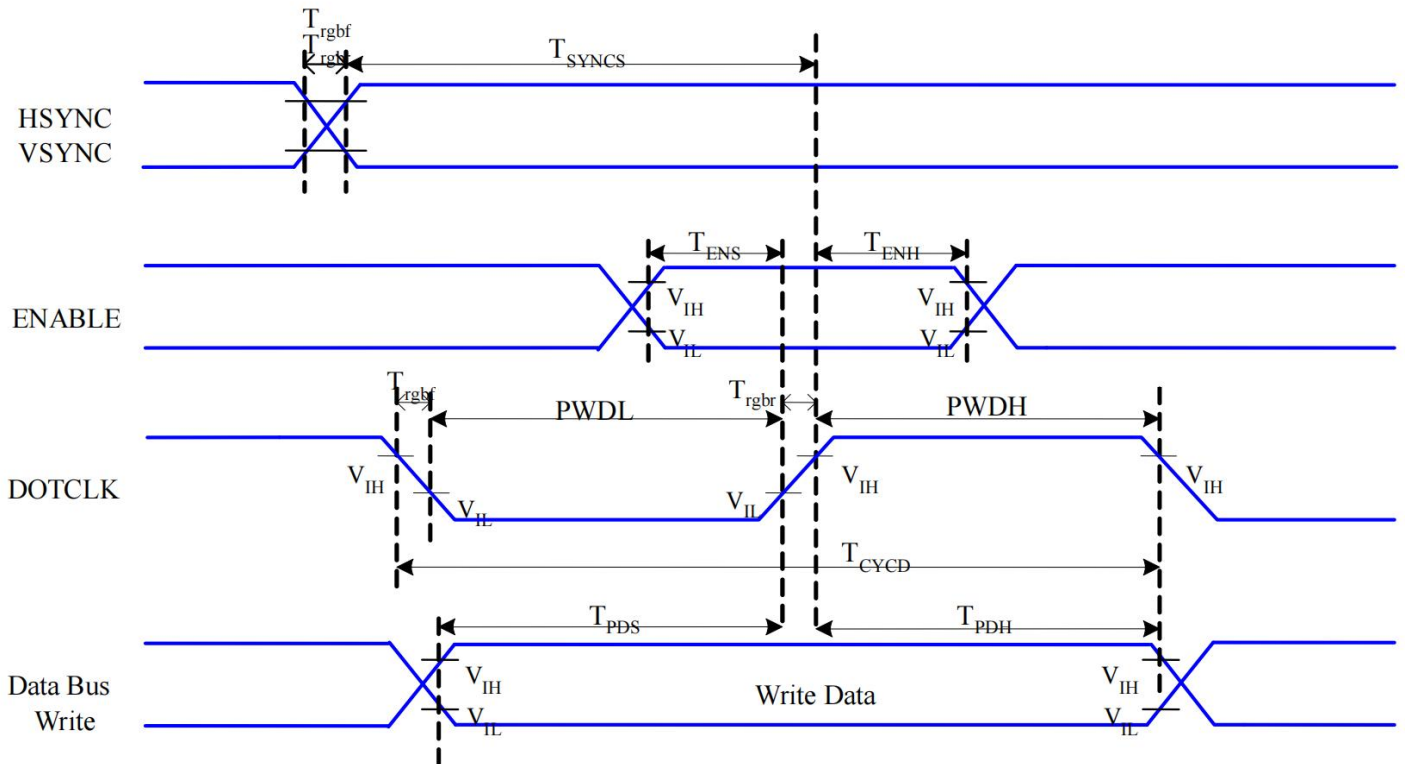

Signal	Symbol	Parameter	MIN	MAX	Unit	Description
HSYNC, VSYNC	T_{SYNCS}	VSYNC, HSYNC Setup Time	30	-	ns	
ENABLE	T_{ENS}	Enable Setup Time	25	-	ns	
	T_{ENH}	Enable Hold Time	25	-	ns	
DOTCLK	PVDH	DOTCLK High-level Pulse Width	60	-	ns	
	PVDL	DOTCLK Low-level Pulse Width	60	-	ns	
	T_{CYCD}	DOTCLK Cycle Time	120	-	ns	
	Trghr, Trghf	DOTCLK Rise/Fall time	-	20	ns	
DB	T_{PDS}	PD Data Setup Time	50	-	ns	
	T_{PDH}	PD Data Hold Time	50	-	ns	



2.2.4 Reset Timing :

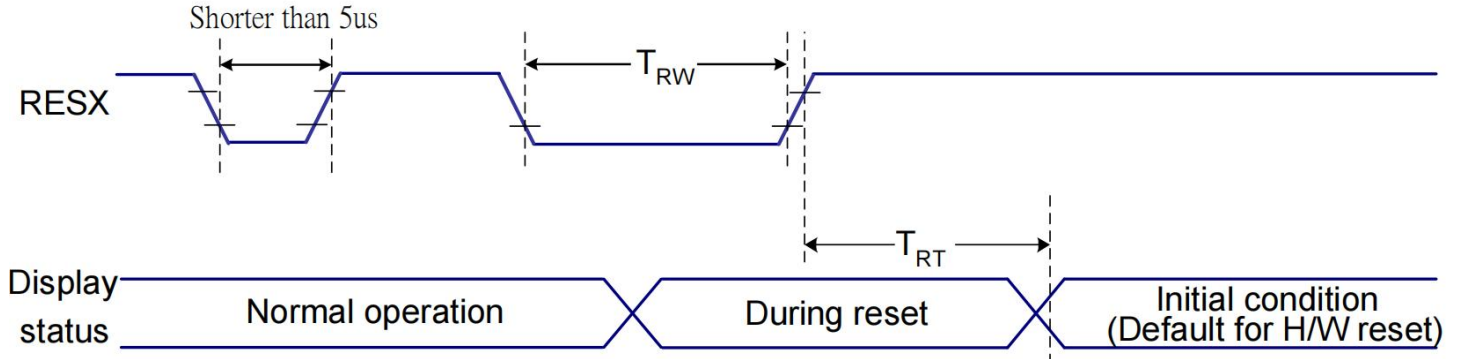

VDDI=1.65 to 3.3V, VDD=2.4 to 3.3V, AGND=DGND=0V, Ta=25°C

Related Pins	Symbol	Parameter	MIN	MAX	Unit
RESX	TRW	Reset pulse duration	10	-	us
	TRT	Reset cancel	-	5 (Note 1, 5)	ms
			120 (Note 1, 6, 7)	ms	

Notes:

1. The reset cancel includes also required time for loading ID bytes, VCOM setting and other settings from NVM (or similar device) to registers. This loading is done every time when there is HW reset cancel time (tRT) within 5 ms after a rising edge of RESX.

2. Spike due to an electrostatic discharge on RESX line does not cause irregular system reset according to the table below:

RESX Pulse	Action
Shorter than 5us	Reset Rejected
Longer than 9us	Reset
Between 5us and 9us	Reset starts

3. During the Resetting period, the display will be blanked (The display is entering blanking sequence, which maximum time is 120 ms, when Reset Starts in Sleep Out –mode. The display remains the blank state in Sleep In –mode.) and then return to Default condition for Hardware Reset.

4. Spike Rejection also applies during a valid reset pulse as shown below:

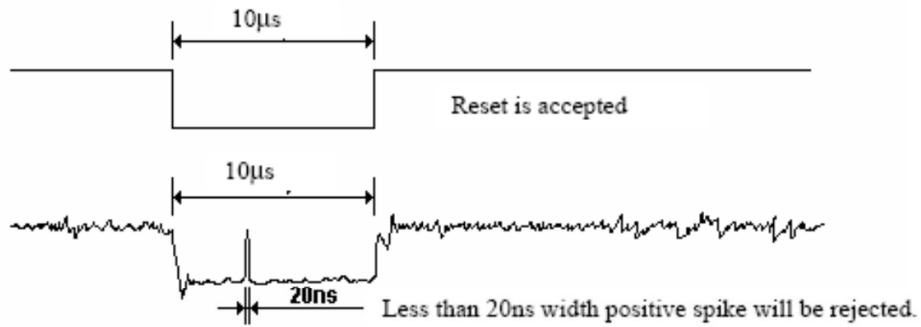

5. When Reset applied during Sleep In Mode.

6. When Reset applied during Sleep Out Mode.

7. It is necessary to wait 5msec after releasing RESX before sending commands. Also Sleep Out command cannot be sent for 120msec.



3. Inspection Specification

- ◆Scope : The document shall be applied to TFT-LCD Module for 0.96" ~12. 3" (Ver.A01).
- ◆Inspection Standard : MIL-STD-105E Table Normal Inspection Single Sampling Level II.
- ◆Equipment : Gauge 、 MIL-STD 、 SmartWin Tester 、 Sample
- ◆Defect Level : Major Defect AQL : 0.65 ; Minor Defect AQL : 1.5
- ◆OUT Going Defect Level : Sampling.
- ◆Standard of the product appearance test :

a. Manner of appearance test :

- (1). The test best be under 20W×2 fluorescent light(about 300lux ~500lux)
， and distance of view must be at 30~40 cm.
- (2). The test direction is base on about around 45° of vertical line.

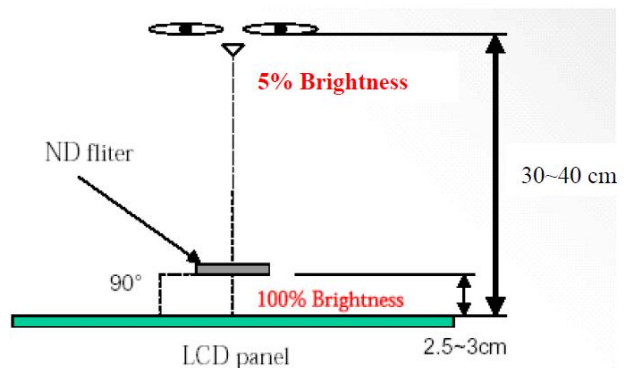
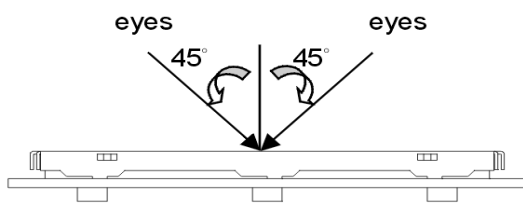

(3). Definition of area.

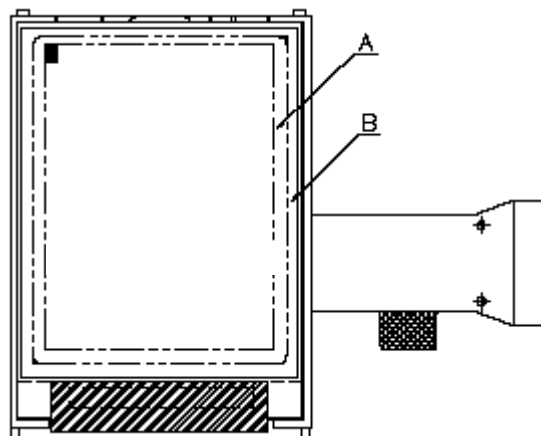

A area : viewing area

B area : Outside of viewing area

(4). Standard of inspection : (Unit : mm)



3.1 Major defect

Item No	Items to be inspected	Inspection Standard
3.1.1	All functional defects	1) No display 2) Display abnormally 3) Short circuit 4) line defect
3.1.2	Missing	Missing function component
3.1.3	Crack	Glass Crack

3.2 Minor defect

Item No	Items to be inspected	Inspection Standard	
3.2.1	Polarizer dirt and spot	For dark/white spot is defined	
		$\varphi = (x+y) / 2$	
		Size φ (mm)	Acceptable Quantity
		$\varphi \leq 0.15$	Ignore
		$0.15 < \varphi \leq 0.50$	2
$0.50 < \varphi$	0		

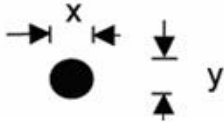
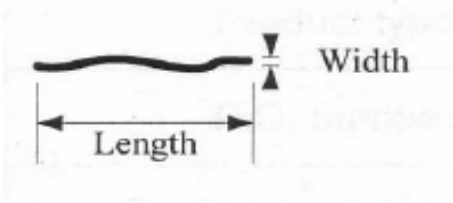

Item No	Items to be inspected	Inspection Standard	
3.2.2	Panel dirt and spot	For dark/white spot is defined $\varphi = (x+y) / 2$ 	
		Size φ (mm)	Acceptable Quantity
		$\varphi \leq 0.10$	Ignore
		$0.10 < \varphi \leq 0.25$	3
		$0.25 < \varphi$	Not allowed
3.2.3	Line Defect Including Black line White line Scratch	Define: 	
		Width(mm) Length(mm)	Acceptable Quantity
		$W \leq 0.03$	Ignore
		$0.03 < W \leq 0.07$ $L \leq 5.0$	3
		$W > 0.07$	As round type



3.2.4	Polarizer Dent/Bubble	Size φ (mm)		Acceptable Quantity
		$\varphi \leq 0.15$		Ignore
		$0.15 < \varphi \leq 0.50$		2
		$0.50 < \varphi$		0
3.2.5	Electrical Dot Defect	Item		Acceptance (Q'ty)
		Dot Defect	Bright dot	$\cong 4$
			Dark dot	$\cong 4$
Inspection pattern: full white, full black, Red, Green and blue screens. It is defined as dot defect if defect area $> 1/2$ dot. The distance between two dot defect $\cong 5$ mm. Bright dot that can not be seen through 2% ND filter.				
3.2.6	Mura	Visible through ND5% at fullblack pattern is not allowed		



- Note:
1. Dot defect is defined as the defective area of the dot area is larger than 50% of the dot area.
 2. The distance between two bright dot defects (red, green, blue, and white) should be larger than 5mm.
 3. The distance between black dot defects or black and bright dot defects should be more than 5mm apart.

4. The definitions of the inner display area

And outer display area

I: Inner display area

O: Outer display area

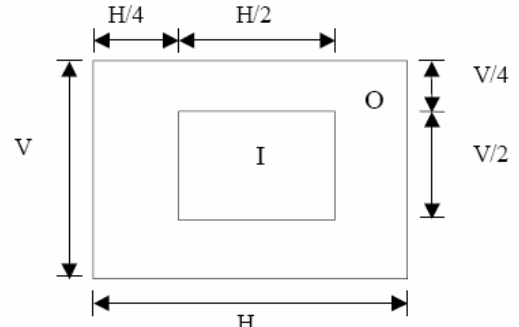

5. Polarizer bubble is defined as the bubble appears on active display area. The defect of polarizer bubble shall be ignored if the polarizer bubble appears on the outside of active display area.



5. PRECAUTION RELATING PRODUCT HANDLING

Please pay attention to the following items when you use the LCD Modules:

- 5-1 Do not twist or bend the module and prevent the unsuitable external force for display module during assembly.
- 5-2 Adopt measures for good heat radiation. Be sure to use the module with in the specified temperature.
- 5-3 Avoid dust or oil mist during assembly.
- 5-4 Following the correct power sequence while operating. Do not apply the invalid signal, otherwise, it will cause improper shut down and damage the module.
- 5-5 Less EMI: it will be more safety and less noise.
- 5-6 Please operate module in suitable temperature. The response time & brightness will drift by different temperature.
- 5-7 Avoid to display the fixed pattern (exclude the white pattern) in a long period, otherwise, it will cause image stains.
- 5-8 Be sure to turn off the power when connection of disconnecting the circuit.
- 5-9 Polarizer scratches easily, please handle it carefully.
- 5-10 Display surface never likes dirt of stains.
- 5-11 A dew drop may lead to destruction. Please wipe off and moisture before using module.
- 5-12 Sudden temperature changes cause condensation, and it will cause polarizer damaged.
- 5-13 High temperature and humidity may degrade performance. Please do not expose the module to the direct sunlight and so on.
- 5-14 Acetic acid or chlorine compounds are not friends with TFT display module.
- 5-15 Static electricity will damage the module; please do not touch the module without any grounded device.
- 5-16 Do not disassemble and reassemble the module by self.
- 5-17 Be careful do not touch the rear side directly.
- 5-18 Not strong vibration or shock. It will cause module broken.
- 5-19 Storage the modules in suitable environment with regular packing.
- 5-20 Be careful or injury from a broken display module.
- 5-21 Please avoid the pressure adding to the surface (front or rear side) of modules, because it will cause the display non-uniformity of other function issue.

REV	REVISION RECORD	DATE
△	ACCORDING TO CUSTOM'S SPEC	2024-12-03

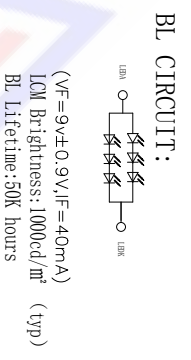
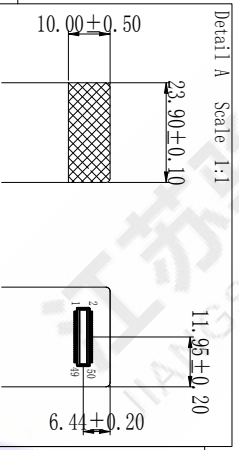
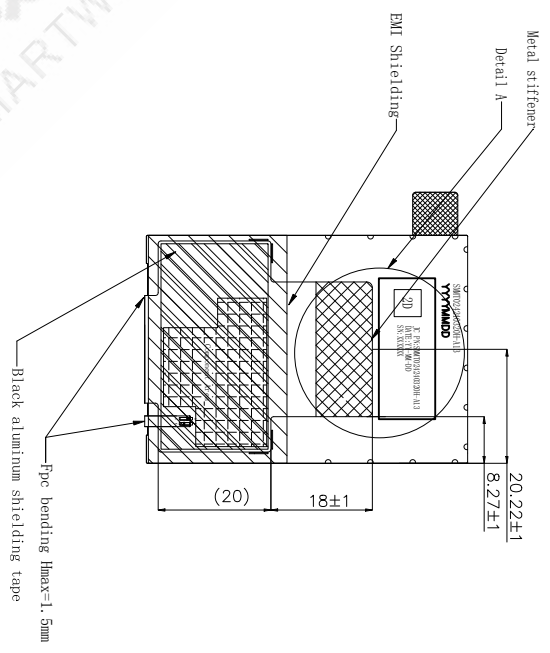
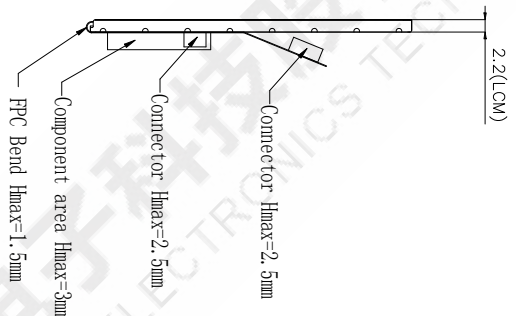
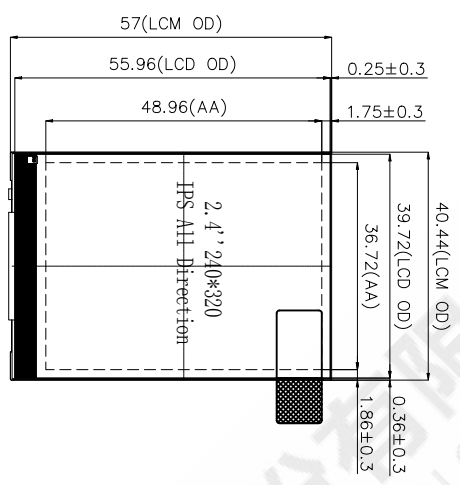

1	SMRQ
2	GND
3	GND
4	GND
5	+3V3 BK1
6	+3V3 BK1
7	+3V3 BK1
8	+3V3 BK1
9	PMW BK1
10	+3V3 F1
11	GND
12	GND
13	GND
14	GND
15	R0
16	R1
17	R2
18	R3
19	R4
20	GND
21	GND
22	GND
23	G2
24	G2
25	G3
26	G4
27	G5
28	GND
29	GND
30	GND
31	R0
32	R1
33	R2
34	R3
35	R4
36	R5
37	VDDC
38	HSINC
39	HSINC
40	GND
41	FPCK
42	GND
43	MODE(SD)B1
44	FT-RESET
45	NC
46	NC
47	ZPC_SDA EEPROM
48	ZPC_SCL EEPROM
49	+3V3 EEPROM
50	GND

CONFIRM ALL TYPE DRAWINGS OF THIS AND PASS BACK!

OPERATING VOLTAGE: 3.3V	OPERATING CURRENT: --
DISPLAY TYPE: Normally black	VIEW DIRECTION: Free
LCD Resolution: 240 RGB X 320	CTP Interface:
LCD CONTROLLER: ST7789T3	CTP CONTROLLER:
BACK LIGHT: If=40mA, Vf=9V	
OPERATING TEMPERATURE: -30°C TO 80°C (240hrs)	STORAGE TEMPERATURE: -30°C TO 80°C (240hrs)
DEFAULT TOLERANCE: ±0.2	ROHS STANDARD: YES

	江苏骏成电子科技有限公司 JIANGSU SMARTWIN ELECTRONICS TECHNOLOGY Co.,LTD	TITLE	模块外形图	CUSTOMER NUMBER	-	REV	A
DES' D BY	陈恩添	PRODUCT MODEL	SMR1024240320H-A13-WX	UNIT	mm	DATE	2024-12-03
CHK' D BY		SERIAL NUMBER		SCALE	1:1	NO.	1/1
APPROVED							