

Recommended assembly:

Inner cable clamp application

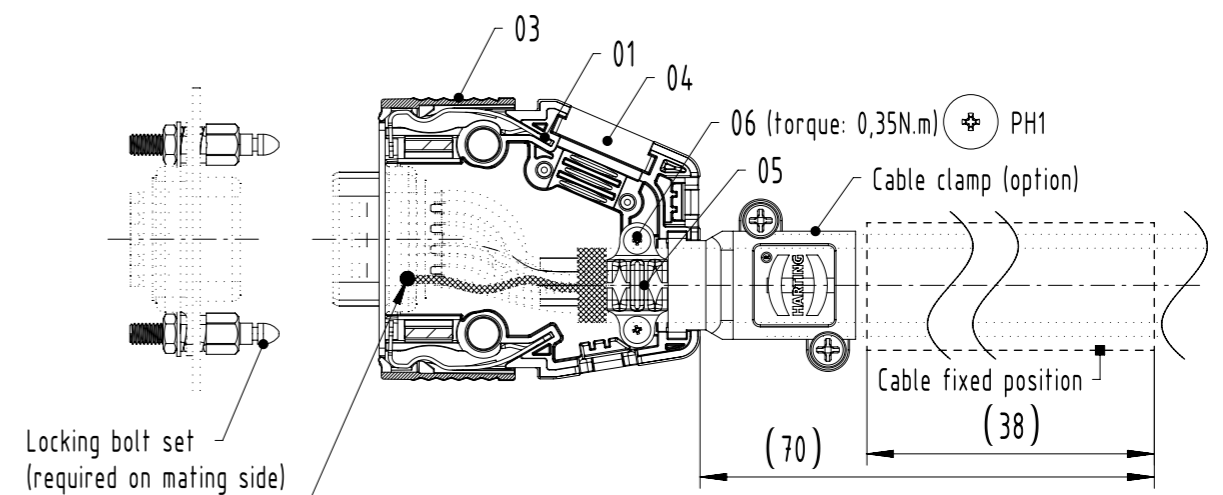

It is necessary that the screen of the cable is connected to the D-sub shell for metalized version of this product with a low-resistance electrical connection (wire $\geq 0,75 \text{ mm}^2$), if the application needs to fulfil the requirements for transfer impedance acc. to VG 95373-25, pic. 1: 2016-02 of shielded cable

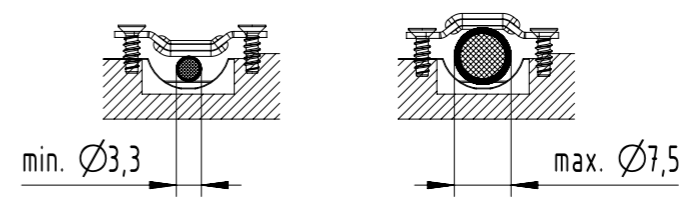
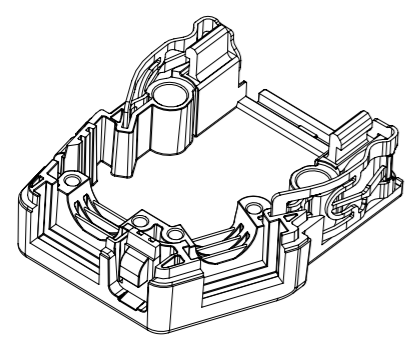

01 x1 piece

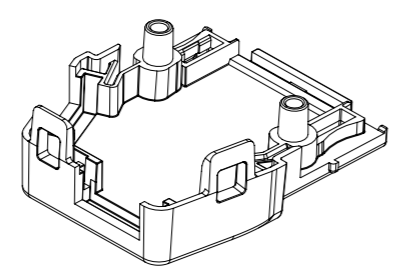

02 (enclosed) x1 piece

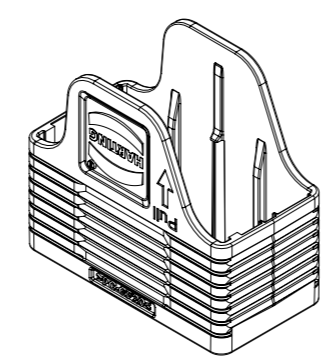

03 (enclosed) x1 piece

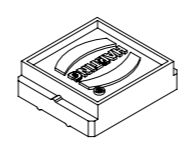

04 (enclosed) x1 piece

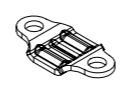

05 (enclosed) x1 piece



06 (enclosed) x2 pcs

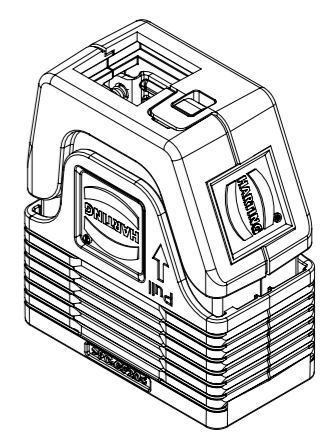

06	--	ISO 7050-ST2,2x6,5-A2-20H-F-H	x2
05	--	D-Sub ca-clamp for 9P, 15P hood	x1
04	--	plastic metallized blank piece 9P-37P	x1
03	--	D-Sub NAH 9P Moveable cover	x1
02	--	D-sub NAH 9P Hood TC metallized	x1
01	--	D-sub NAH 9P Hood BC metallized+lock spring	x1
1	09 67 009 0210	D-Sub_CCH_S1_PP_PL_PLA	1 set
ITEM NO.	PART NUMBER	PART NAME	QTY

		All rights reserved Department EL PD		All Dimensions in mm Original Size DIN A3		Scale 1:1 Free size tol.		Ref. Sub.	
HARTING D-32339 Espelkamp		Created by wene Inspected by luok		Standardisation		Date 18-Mar-2025 State 40 - Released		Title D-Sub_CCH_S1_PP_PL_PLA Doc-Key / ECM-Nr. DS00244398	
Type TB		Design Number DS00244398		SAP Mat. Number 09670090210		Rev. C		Page 1/1	