

AT ALL TIMES WATER RESISTANT CONNECTORS NOT IN USE SHOULD BE COVERED WITH A CONEC WATER RESISTANT CAP OR WATER TIGHT HOOD.

(5:1)

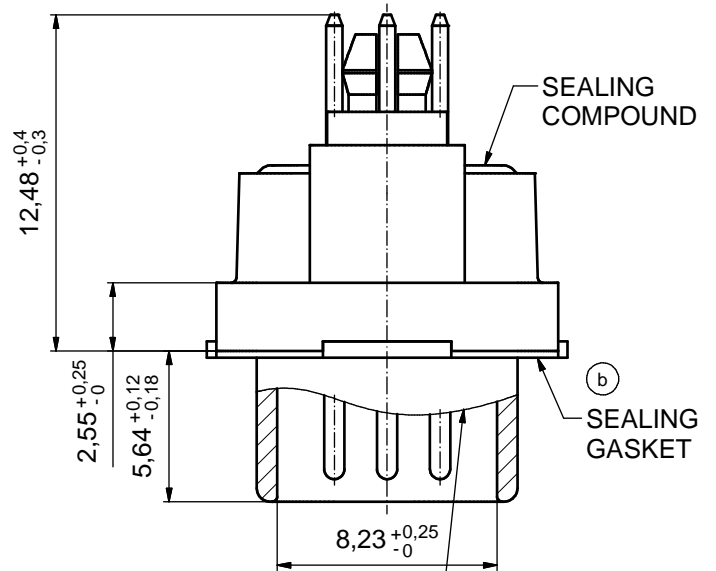

RUBBER GASKET PLACED ON TOP SURFACE OF MALE INSULATOR

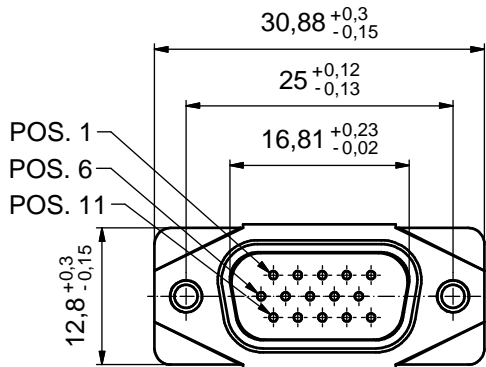
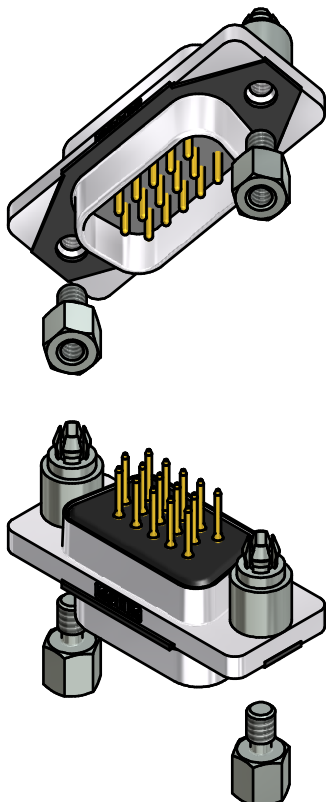
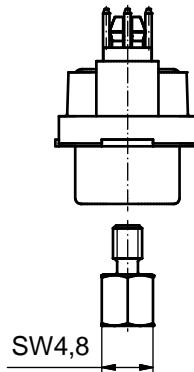
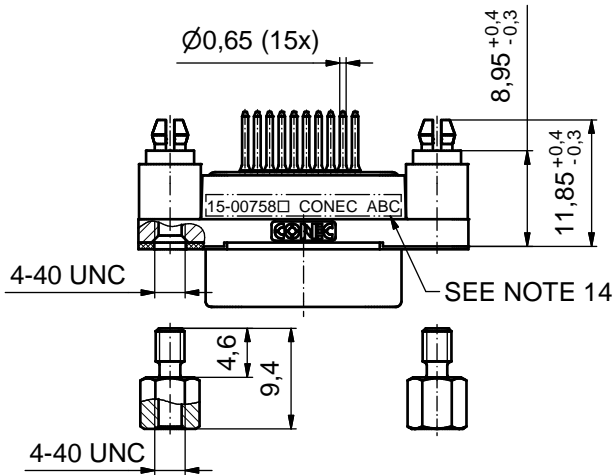

RoHS compliant

(b) NOTES:

1. FOR WAVESOLDERING (SOLDER BATH TEMPERATURE 265°C FOR 8 SEC. AND SOLDER PREHEAT 150°C FOR 180 SEC.)
2. IP RATING: IP 67
3. SEALED TO WITHSTAND PRESSURE UP TO 1,45 PSI FOR 30 MINUTES AFTER SOLDERING
4. METAL SHELL: ZINC DIE CAST; min. 50µm NICKEL PLATING over COPPER
5. INSULATORS: PBT GF UL 94 V-0
6. SEALING GASKET: SILICONE
7. RUBBER GASKET: TPE
8. SEALING COMPOUND: EPOXY
9. CONTACTS: COPPER ALLOY; PLATING (SEE PART-NO.):
□ PLEASE ADD 1 for 30µm HARD GOLD over min. 50µm NICKEL
□ PLEASE ADD 3 for GOLD FLASH over NICKEL
10. REAR SPACER CLIPS: COPPER ALLOY; min. 200µm TIN over 80µm NICKEL
PCB-HOLE: $\varnothing 3,1 \pm 0,1$ mm; PCB THICKNESS 1,6mm
11. HEXLOCKING SCREWS: STAINLESS STEEL
12. P.C.B. HOLE DRILLINGS and RECOMMENDED PANEL CUT-OUT ON SHEET 2
13. RECOMMENDED TORQUE FOR MOUNTING SCREW
35Ncm (3.1 in.LB) / max. 67Ncm (6 in.LB)
14. CONNECTOR IS PART MARKED: 15-00758 □ CONEC ABC (see note 8)

THIS DRAWING MAY NOT BE COPIED OR REPRODUCED IN ANY WAY, AND MAY NOT BE PASSED ON TO A THIRD PARTY WITHOUT WRITTEN PERMISSION. OWNERSHIP AND COPYRIGHT OF CONEC GmbH		tolerance			scale:	2:1 (5:1)
		dim. in mm			material:	SEE NOTES
DO NOT ALTER CAD DRAWING BY HAND		date	name	title: D-SUB MALE HD 15pos. SOLDER PIN STRAIGHT with closed 4-40 UNC thread and rear spacer clip		
		drawn 05.10.2015	Heinrich			
2 x b		appd.	Fischer	dwg no: 15K1A1683		
		norm				
a		d-old		part no: 15-00758 □ (see note 9)		
		rev.	description			
ORIGINAL		CONEC ®		DIN-A3 sh: 1		

P.C.B. HOLE DRILLINGS

(P.C.B. TOP SIDE)

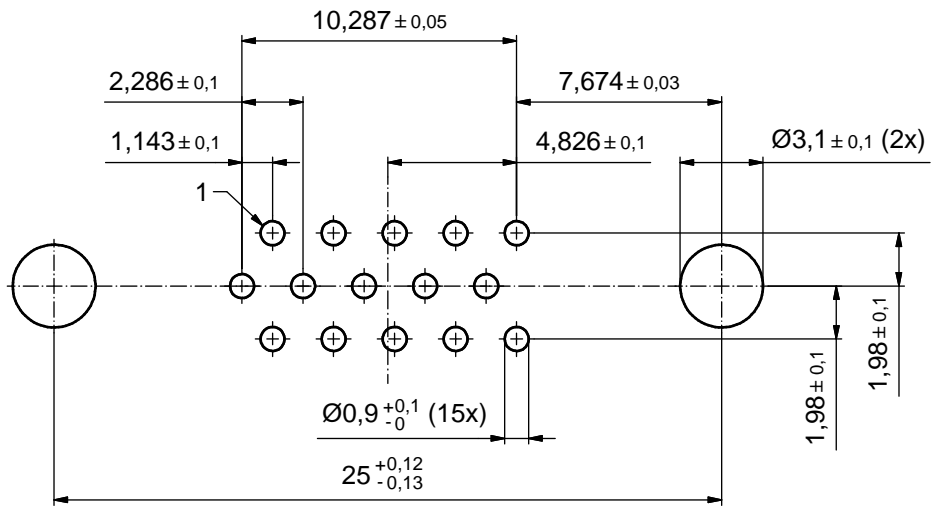

RECOMMENDED PANEL CUT-OUT

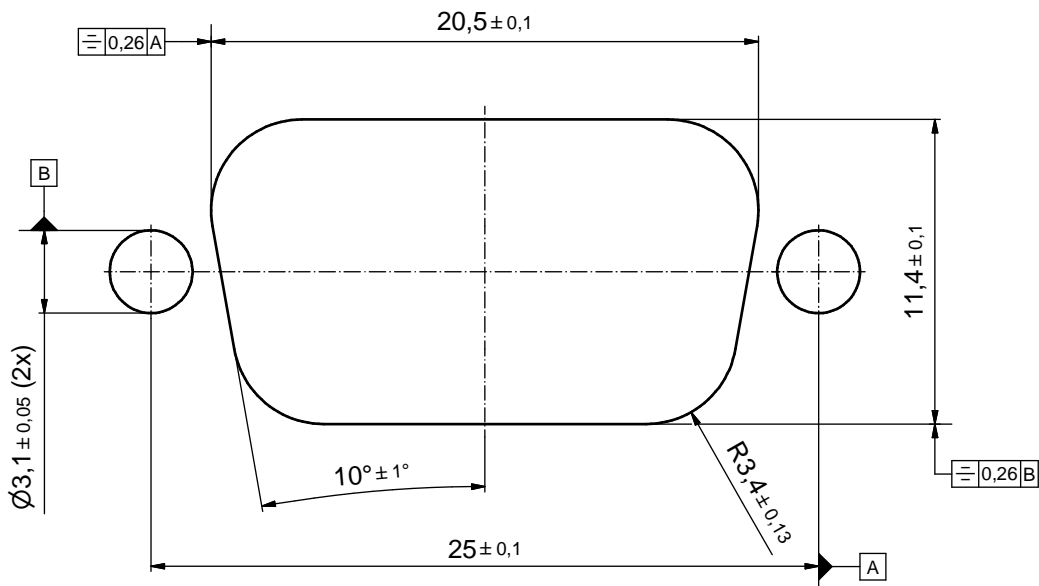

THIS DRAWING MAY NOT BE COPIED OR REPRODUCED IN ANY WAY, AND MAY NOT BE PASSED ON TO A THIRD PARTY WITHOUT WRITTEN PERMISSION. OWNERSHIP AND COPYRIGHT OF CONEC GmbH DO NOT ALTER CAD DRAWING BY HAND				tolerance		scale: 5:1
				date	name	material: SEE SHEET 1
				drawn	05.10.2015	Heinrich
				appd.	12.10.2015	Fischer
				norm		
			d-old			
			rev.	a	Original	title: P.C.B. HOLE DRILLINGS RECOMMENDED PANEL CUT-OUT D-SUB MALE HD 15pos. SOLDER PIN STRAIGHT
			description			dwg no: 15K1A1683
			date			DIN-A3
			name			sh: 2
			CONEC®			part no: SEE SHEET 1