

DETAIL C

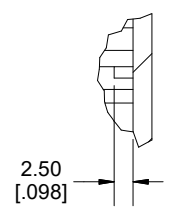

DETAIL D

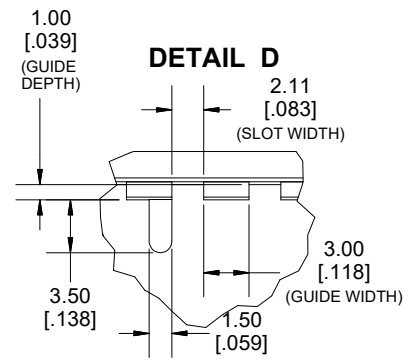

Enclosures can be Factory Modified (Milling, Drilling, Printing etc.)
 Contact Factory (modshop@hammfg.com) for quotes
 Solid models of this enclosure available in .stp or .x_t
 (Part number and text placement/orientation on our products are subject to change,
 we do not recommend using them as a locating reference for modification purposes)

NOTE		
Purchased assembly includes box, lid, 4 cover screws, and pre-installed brass inserts.		
Enclosure made from Polycarbonate.		
Recommended Torque: 42-57 ozf.in (30-40 cN.m)		
PART NUMBERS		
1591DT Enclosure		
Material	Colour	Part Number
Translucent Polycarbonate	Ice Blue	1591DTBU
	IR Red	1591DTRD
	Crystal Clear	1591DTCL
Accessories		
Plated Cover screw	1591MS100 (Silver)	
M3 - 0.5 X 10mm (100Pkg)	1591MS100BK (Black)	
PC Board Card Adapters	1591Z6 (6Pkg)	
	1591Z50 (50 Pkg)	
	1591Z100 (100Pkg)	
Nylon Belt / Pocket clip	1599CLIP (Black)	
	1599CLIPGY (Grey)	
Clear Lids - Flame Retardant Polycarbonate - Lid ONLY	1591DC	

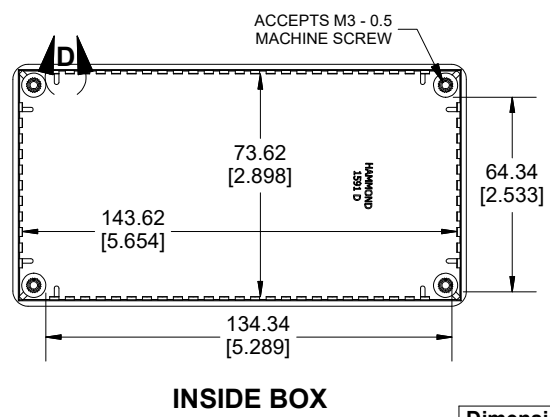
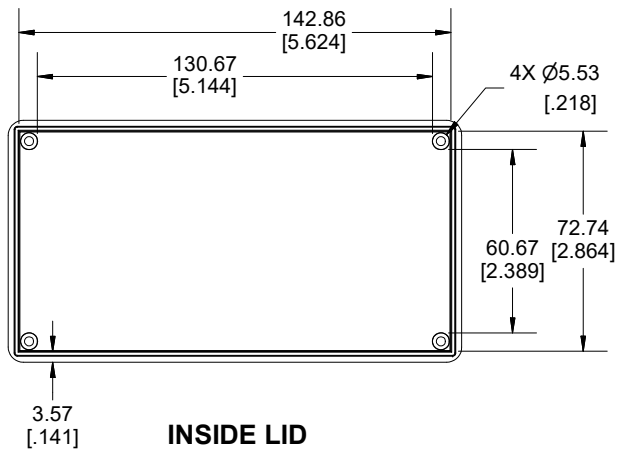

Dimensions:
 mm
 [inches]

HAMMOND MANUFACTURING
 1591DT
 www.hammondmfg.com