

Enclosures can be Factory Modified (Milling, Drilling, Printing etc.)  
 Contact Factory (modshop@hammfg.com) for quotes  
 Solid models of this enclosure available in .stp or .x\_t  
 (Part number and text placement/orientation on our products are subject to change,  
 we do not recommend using them as a locating reference for modification purposes)

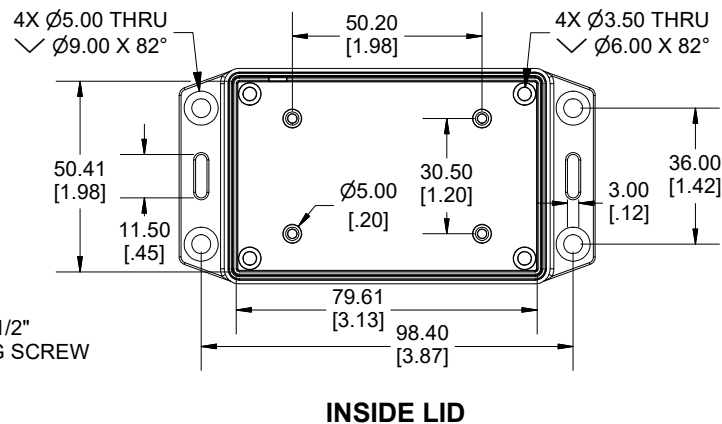
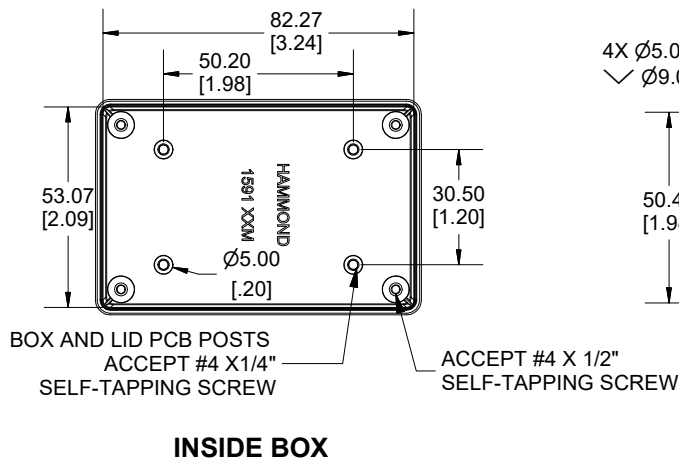

NOTE	
Tab dimensions show maximum size, tab may vary.	
Purchased assembly includes box, lid and 4 cover screws.	
Enclosure molded from GPABS Plastic.	
Other materials / colours available consult factory.	
Recommended Torque : (35-43) Oz.in / (25-30) cN.m	

PART NUMBERS	
1591XXMSFL Enclosure	
Black Textured Enclosure	1591XXMSFLBK
ACCESSORIES	
Black Cover Screws #4 X 1/2" Self-tapping	1591TS100BK (Pkg 100)
Plated Cover Screws #4 X 1/2" Self-tapping	1591TS100 (Pkg 100)
P.C. Board Screws	1593ATS50 (Pkg 50)
[#4 x 1/4" self-tapping (6.4mm)]	1593ATS100 (Pkg 100)

Dimensions:  
mm  
[inches]

**HAMMOND  
MANUFACTURING.**  
1591XXMSFL  
www.hammondmfg.com