

Recommended Single-D Panel Cutout

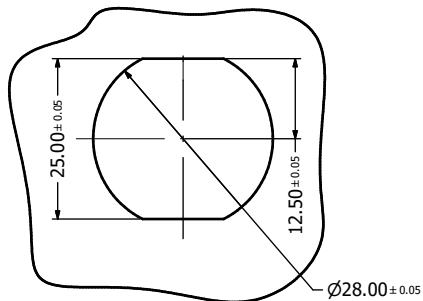

Recommended Double-D Panel Cutout

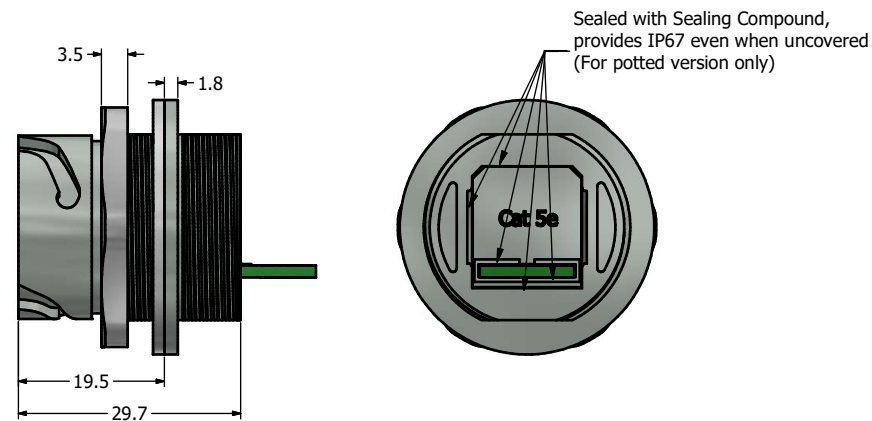
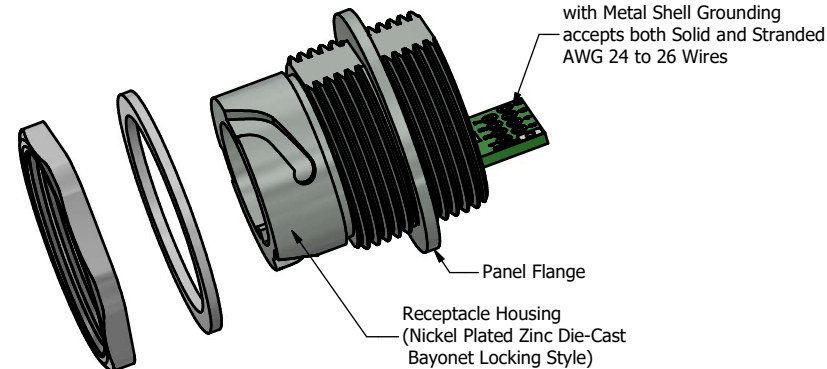
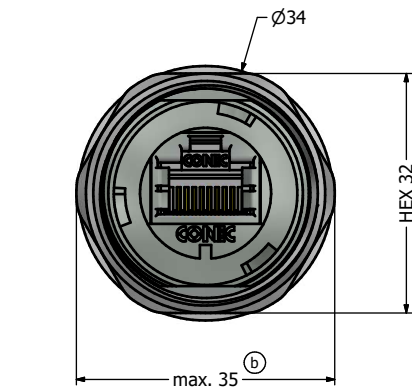
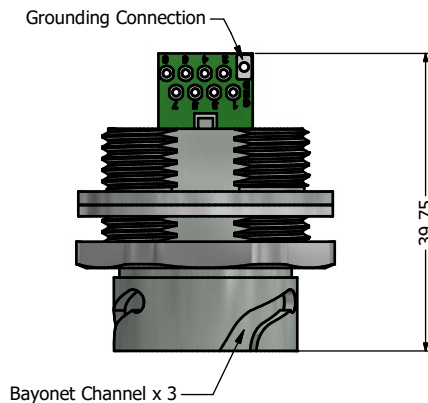

Notes:

1. Electrical Specifications:

- Meets EIA/TIA-568-B.2 Cat.5e Specification
- Contact Resistance: 20mOhm max.
- Insulation Resistance: 500MOhm min. @ 100 VDC
- Current Rating: 1.2A max. at 25° C
- Working Voltage: 100 VDC
- DWV: 1000 VDC/60s Contact to Contact, 1500 VDC/60s Contact to Metal Shell
- Operating Temperature: -40° C to +85° C

2. Material and Finish:

- Receptacle Housing: Zinc Die-Cast, Nickel Plated, UL94 V-0
- Panel Nut: Brass, Finish: Nickel Plated
- Panel Gasket: Silicon, Color: White
- Cat.5e RJ45 PCB Jack Metal Shell: Copper Alloy, Nickel Plated
- Cat.5e RJ45 PCB Jack Plastic Housing: Glass filled PBT UL94 V-0, Color: Black
- Cat.5e RJ45 PCB Jack Contacts: Phosphor Bronze, Finish: 50u" Gold min. over Nickel

3. Connector can be front or rear mounted to a maximum panel thickness of 3.2mm.

4. IP67 rated when covered or fully mated with the appropriate mating connector

5. Recommended Mounting Panel Nut torque is 20 to 25 lb-inch

RoHS compliant

Description	Part Number
Nickel Plated Zinc Die-Cast Version	17-110404
Potted Nickel Plated Zinc Die-Cast Version	17-110414

THIS DRAWING MAY NOT BE COPIED OR REPRODUCED IN ANY MANNER WITHOUT THE WRITTEN PERMISSION OF CONEC CORPORATION. OWNERSHIP AND COPYRIGHT OF CONEC CORPORATION.	Customer:			Tolerance Unless otherwise specified			Scale:	Dim. in mm
	Name	Title	Approval Date	0 PLC ±0.50	1 PLC ±0.38		Name Vincent Ke J. Chaudry	Material: See Notes
				2 PLC ±0.25	3 PLC ±0.10	Date Oct. 09 Oct. 09		Receptacle Assembly Kit with Nickel Plated Zinc Die-Cast Housing + Shielded Cat. 5e RJ45 PCB Jack Version-II
				ANGLES ±3°			Appd. Norm. D-old	Drawing No.: 17K1A361
1 x b	A21-04.26	03.11.2021	Bub			Part No.: SEE PART NUMBER TABLE		Sheet 1/1
a	original					Rev.	Changes	Date