

Piezoscheiben EPZ-15MS60W Art.-Nr.: 190023

Specification :

TYPE	UNIT	EPZ-15MS60W
Dimensions (mm)	D	15
	d	9
	T	0.22
	t	0.10
	L	35±3
	l	2±1
Wire		UL1571 AWG30#red
Frequency	Hz	5.000
Impedance	Ω	1.500
Capacitance	pF	11.000
Operating Temperature	°C	-20~+70
Storage Temperature	°C	-30~+80

Dimensions :

(Unit : mm)

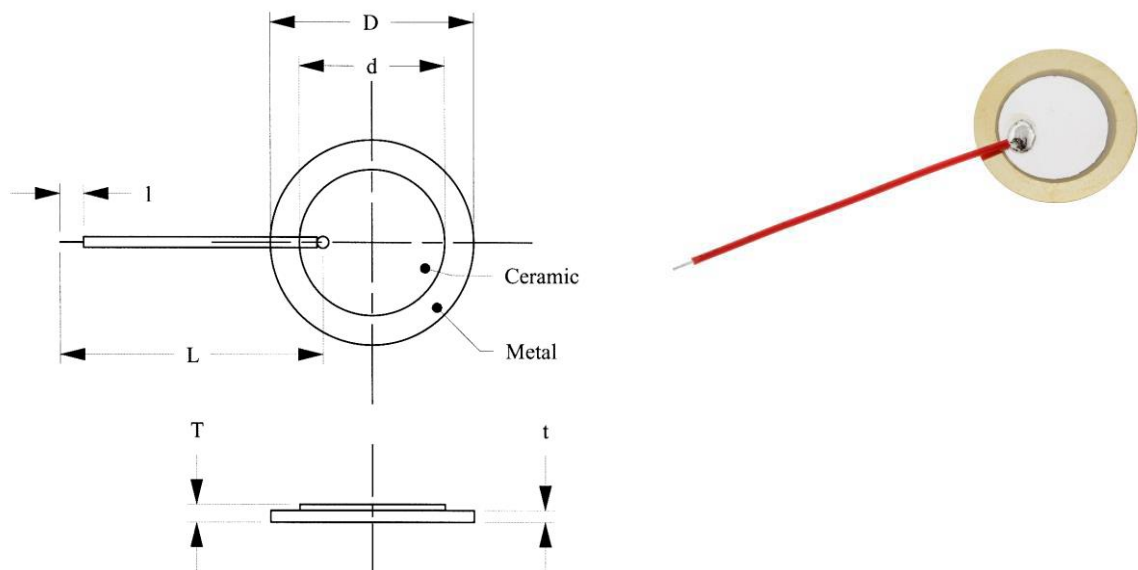

Piezoscheiben EPZ-15MS60W Art.-Nr.: 190023
