

MEMS-Mikrofon MS4030Z1CM-25 Art.-Nr.: 200730

Specification :

ABSOLUTE MAXIMUM RATINGS

Parameter	Maximum value	Unit
Supply Voltage	-0.3 to 4.0	V
Sound Pressure Level	140	dB SPL
Storage temperature	-40 to 100	°C

ACOUSTIC & ELECTRICAL SPECIFICATIONS

TEST CONDITIONS: 23 ±2°C, 55±20% R.H., VDD=1.8 V, f_{CLOCK}=2.4 MHz, L/R pin grounded, no load, unless otherwise indicate

General Microphone Specifications

Parameter		Symbol	Conditions	Min	Typ	Max	Units
Supply Voltage		V _{DD}		1.6	-	3.6	V
Clock Frequency Range	Sleep Mode			0		50	KHz
	Low-Power Mode			150		900	KHz
	Standard Performance Mode			1.1		4.0	MHz
Sleep Current		I _{SLEEP}	f _{CLOCK} ≤ 50 kHz	-	1		µA
DC Output			Fullscale = ±100	-	4	-	% FS
Directivity				Omnidirectional			
Polarity			Increasing sound	Increasing density of 1's			
Data Format				½ Cycle PDM			
Short Circuit Current		I _{SC}	Grounded DATA pin	1	-	10	mA
Output Load		C _{LOAD}		-	-	200	pF
Fall-asleep Time			f _{CLOCK} ≤ 50 kHz	-	-	30	µs
Wake-up Time			f _{CLOCK} ≥ 151 kHz	-	-	200	µs
Power-up Time			V _{DD} ≥ V(min)	-	6	20	ms
Mode-Change Time				-	-	10	ms

MEMS-Mikrofon MS4030Z1CM-25 Art.-Nr.: 200730

Standard Performance Mode

TEST CONDITIONS: $f_{\text{clock}} = 2.4 \text{ MHz}$, $V_{\text{DD}} = 1.8 \text{ V}$, unless otherwise indicated

Parameter	Symbol	Conditions	Min	Typ	Max	Units
Supply Current	I_{DD}	$f_{\text{clock}} = 2.4 \text{ MHz}$	-	670	-	μA
Sensitivity	S	94 dB SPL @ 1 kHz	-27	-26	-25	dBFS
Signal to Noise Ratio	SNR	20 kHz bandwidth, A-weighted $f_{\text{clock}} = 2.4 \text{ MHz}$	-	64	-	dB(A)
Total Harmonic Distortion	THD	94 dB SPL @ 1 kHz, S = Typ	-	0.1	-	%
Acoustic Overload Point	AOP	10% THD @ 1 kHz, S = Typ	-	120	-	dB SPL
Power Supply Rejection Ratio	PSRR	200 mVpp sinewave @ 1 kHz	-	50	-	dBV/FS
Power Supply Rejection	PSR+N	100 mVpp square wave @ 217 Hz, A-weighted	-	-80	-	dBFS(A)

MEMS-Mikrofon MS4030Z1CM-25 Art.-Nr.: 200730

Low-Power Mode

 TEST CONDITIONS: $f_{\text{clock}} = 768 \text{ kHz}$, $V_{\text{DD}} = 1.8 \text{ V}$, unless otherwise indicated

Parameter	Symbol	Conditions	Min	Typ	Max	Units
Supply Current	I_{DD}	$f_{\text{clock}} = 768 \text{ kHz}$	-	290	-	μA
Sensitivity	S	94 dB SPL @ 1 kHz	-26	-25	-24	dBFS
Signal to Noise Ratio	SNR	94 dB SPL @ 1 kHz, A-weighted(20Hz-8KHz)	-	62	-	dB(A)
Total Harmonic Distortion	THD	94 dB SPL @ 1 kHz, S = Typ	-	0.1	-	%
Acoustic Overload Point	AOP	10% THD @ 1 kHz, S = Typ	-	120	-	dB SPL
Power Supply Rejection Ratio	PSRR	200 mVpp sinewave @ 1 kHz	-	50	-	dBV/FS
Power Supply Rejection	PSR+N	100 mVpp square wave @ 217 Hz, A-weighted(20Hz-8KHz)	-	-80	-	dBFS(A)

Microphone Interface Specifications

Parameter	Symbol	Conditions	Min	Typ	Max	Units
Logic Input High	V_{IH}		$0.7 \times V_{\text{DD}}$	-	3.6	V
Logic Input Low	V_{IL}		-0.3	-	$0.3 \times V_{\text{DD}}$	V
Logic Output High	V_{OH}	$I_{\text{OUT}} = 2 \text{ mA}$	$V_{\text{DD}} - 0.45$	-	-	V
Logic Output Low	V_{OL}	$I_{\text{OUT}} = 2 \text{ mA}$	-	-	0.45	V
Clock Duty Cycle		-	40	-	60	%

MEMS-Mikrofon MS4030Z1CM-25 Art.-Nr.: 200730

MICROPHONE STATE DIAGRAM

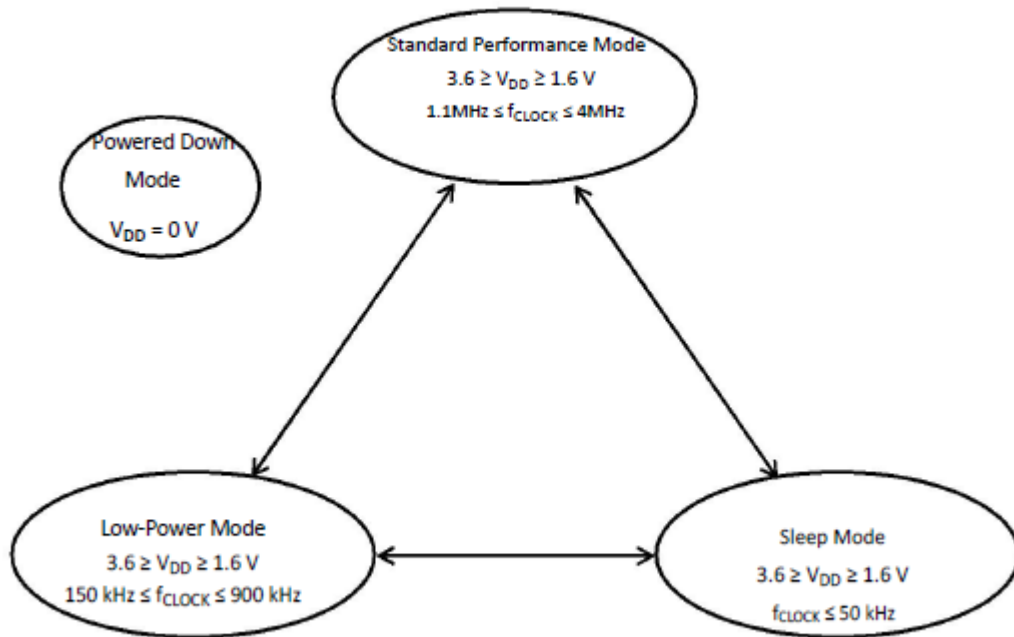

MEMS-Mikrofon MS4030Z1CM-25 Art.-Nr.: 200730

TYPICAL FREQUENCY RESPONSE

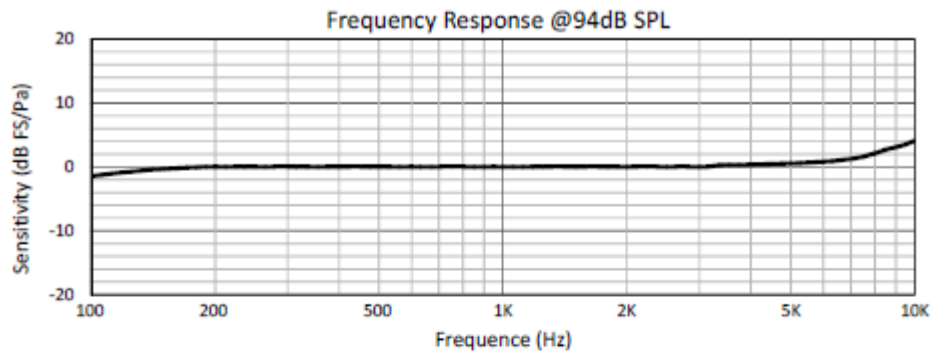

TIMING DIAGRAM

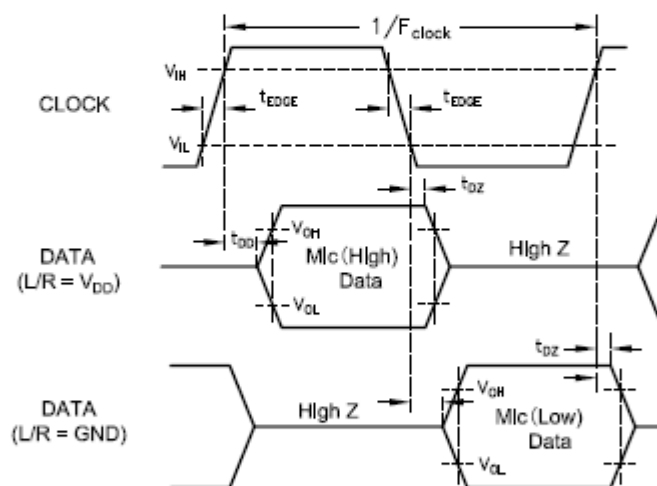

Parameter	Symbol	Min	Typ	Max
Clock Rise/Fall Time	t_{EDGE}	-	-	20ns
Delay Time to High Z	t_{DZ}	-	-	40ns
Delay Time to Data Line Driven	t_{DQ}	-	-	50ns

Microphone	L/R	Asserts DATA on	Latch DATA on
Mic(High)	Vdd	CLK rising edge	CLK falling edge
Mic(Low)	Ground	CLK falling edge	CLK rising edge

MEMS-Mikrofon MS4030Z1CM-25 Art.-Nr.: 200730

SMT Parameters:

1. Recommend PCB land pattern layout: (unit: mm)

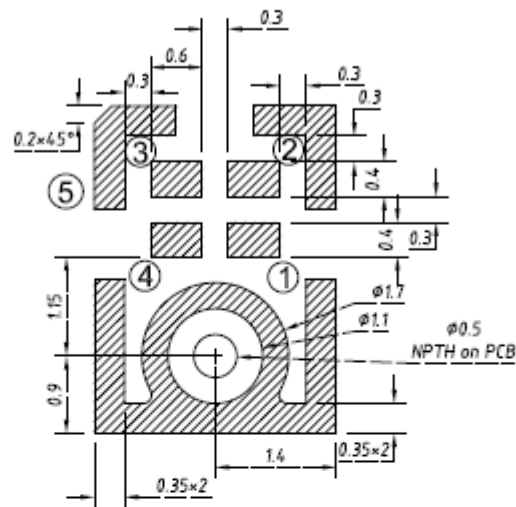

2. Recommend stencil pattern: (unit: mm)

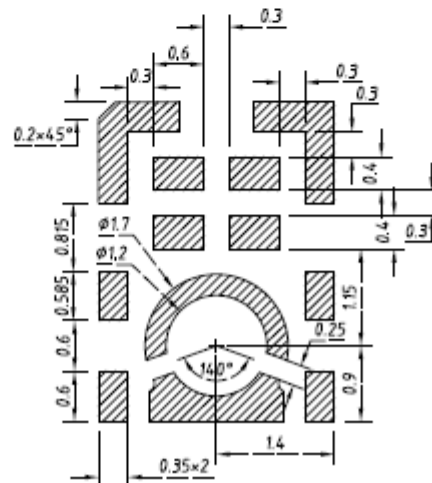

MEMS-Mikrofon MS4030Z1CM-25 Art.-Nr.: 200730

3. Recommend reflow profile:

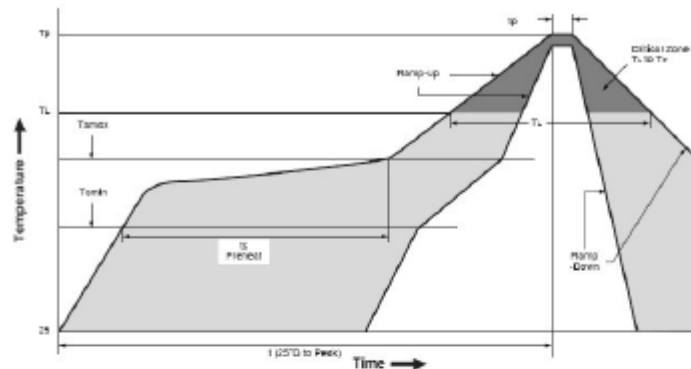

Description	Parameter	Pb free
Average ramp rate	T_L to T_P	3 °C/sec max
Preheat		
Minimum temperature	T_{SMIN}	150 °C
Maximum temperature	T_{SMAX}	200 °C
Time(T_{SMIN} to T_{SMAX})	t_S	60 sec to 120 sec
Ramp-up rate	T_{SMAX} to T_L	1.25 °C/sec max
Time maintained above liquidus temperature	t_L	60 sec to 150 sec
Liquidus temperature	T_L	217 °C
Peak temperature	T_P	260 °C max
Time within 5°C of actual peak temperature	t_p	20 sec to 40 sec
Ramp-down rate	T_L to T_P	6 °C/sec max
Time 25 °C ($t_{25 °C}$) to peak temperature	t	8 minutes max

MEMS-Mikrofon MS4030Z1CM-25 Art.-Nr.: 200730

OUTLINE DIMENSIONS AND PIN DEFINITION:

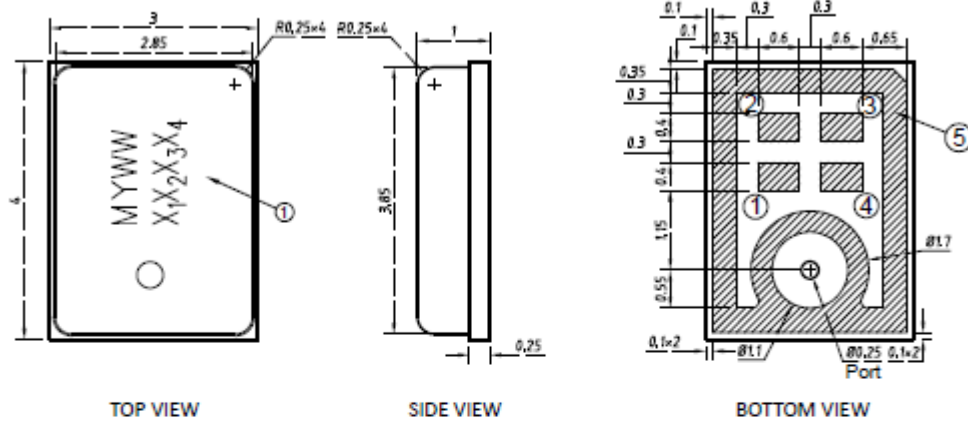
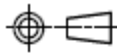

PIN function description

PIN#	Function
1	VDD
2	DATA
3	CLK
4	L/R
5	GND

Item	Dimension	Tolerance
Length (L)	4.0	±0.10
Width (W)	3.0	±0.10
Height (H)	1.0	±0.10
Acoustic Port (AP)	Ø0.25	±0.05

Dimensions are in millimeters, tolerance is ±0.15mm unless otherwise specified.

MYWW X ₁ X ₂ X ₃ X ₄	M	
	Y	Year(A~Z)
	WW	Week
	X ₁ X ₂ X ₃ X ₄	Serial Number

MEMS-Mikrofon MS4030Z1CM-25 Art.-Nr.: 200730

ADDITIONAL NOTES

- (A) MSL (moisture sensitivity level) Class 1.
- (B) Maximum of 3 reflow cycles is recommended.
- I In order to minimize device damage:
 - Do not board wash or clean after the reflow process.
 - Do not brush board with or without solvents after the reflow process.
 - Do not directly expose to ultrasonic processing, welding, or cleaning.
 - Do not insert any object in port hole of device at any time.
 - Do not apply air pressure into the port hole.
 - Do not pull a vacuum over port hole of the microphone.

STORAGE AND TRANSPORTATION

- (A) Keep MEMS MIC in warehouse with less than 75% humidity and without sudden temperature change, acid air, any other harmful air or strong magnetic field.
Recommend floor life (out of bag) at factory no more than 4 weeks.
- (B) The MEMS MIC with normal pack can be transported by ordinary conveyances.
Please protect products against moist, shock, sunburn and pressure during transportation.

MATERIALS STATEMENT

Meet the requirements of standard on hazard substances control
(including RoHS2.0+REACH+Halogen-Free, etc.), with "HSF" identification on label.

MEMS-Mikrofon MS4030Z1CM-25 Art.-Nr.: 200730

PACKAGING & MARKING DETAIL:

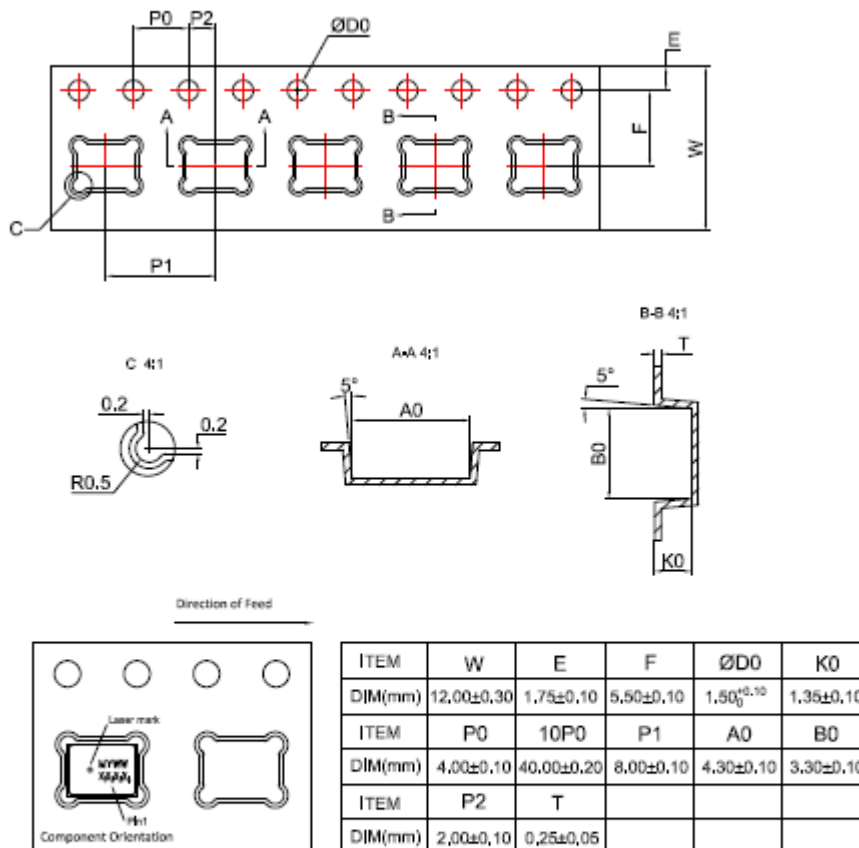

Note:

- 1) Dimensions are in mm;
- 2) Don't put the vacuum suction nozzle alignment the port hole;
- 3) Tape & Reel Per EIA-481 standard;
- 4) Label applied to external package and direct to reel;
- 5) Static voltage <100V;

MEMS-Mikrofon MS4030Z1CM-25 Art.-Nr.: 200730

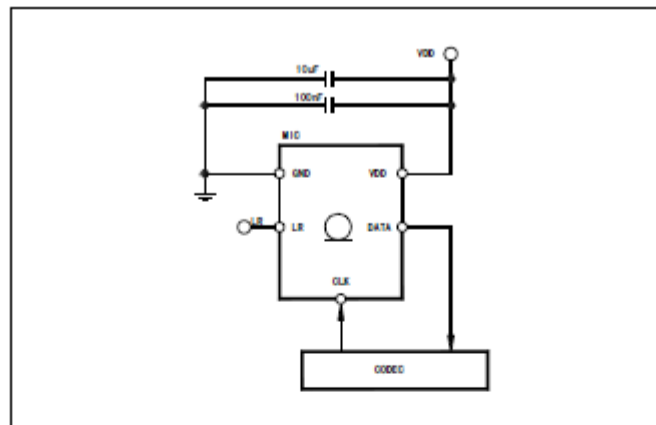

Figuer 2. Electrical connections for stereo configurations

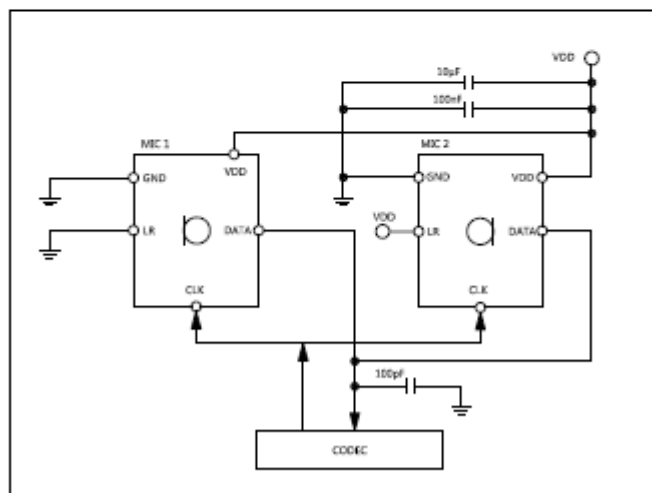

Power supply decoupling capacitors (100nF ceramic, 10uF ceramic) should be placed as near as possible to VDD of the device. (common design practice)

MEMS-Mikrofon MS4030Z1CM-25 Art.-Nr.: 200730

RELIABILITY SPECIFICATIONS

Test	Description
Thermal Shock	100 cycles air-to-air thermal shock from -40°C to +125°C with 15 minute soaks.
High Temperature Storage	1,000 hours at +105°C environment
Low Temperature Storage	1,000 hours at -40°C environment
Reflow	5 reflow cycles with peak temperature of +260°C
ESD-HBM	3 discharges of ±2 kV direct contact to I/O pins.
ESD- LID-GND	3 discharges of ±8 kV direct contact to lid while unit is grounded.
ESD-MM	3 discharges of ±200V direct contact to I/O pins.
Vibration	4 cycles of 20 to 2,000 Hz sinusoidal sweep with 20 G peak acceleration lasting 12 minutes in X, Y and Z directions.
Mechanical Shock	3 pulses of 10,000 G in the X, Y and Z direction
High Temperature Bias	1,000 hours at +105°C under bias
Low Temperature Bias	1,000 hours at -40°C under bias
Temperature/Humidity Bias	1,000 hours at +85°C/85% R.H. under bias.
Drop Test	To be no interference in operation after dropped to 1.0cm steel plate 18 times from 1.5 meter height

NOTE: Sensitivity should vary within ±3dB from initial sensitivity. (The measurement to be done after 2 hours of conditioning at 20±2 °C, R.H 60%~70%)