

SMD-Signalgeber (ohne Ansteuerung) SMD-1411A05 Art.-Nr.: 220013

Specification :

TYPE	UNIT	SMD-1411A05
Oscillation Frequency	Hz	2730
Rated Voltage	V _{0-p}	5
Operating Voltage	V _{0-p}	4~6
Sound Pressure Level	dB	Min. 90 at 10cm
Current Consumption	mA	Max. 90 at Rated Voltage
Coil Resistance	Ω	40 ± 3
Housing Material		LCP (Black)
Operating Temperature	°C	-20~+70
Storage Temperature	°C	-30~+85
Weight	g	1.0

Dimensions : Tolerance : ±0,5mm Except Specified
(Unit : mm)

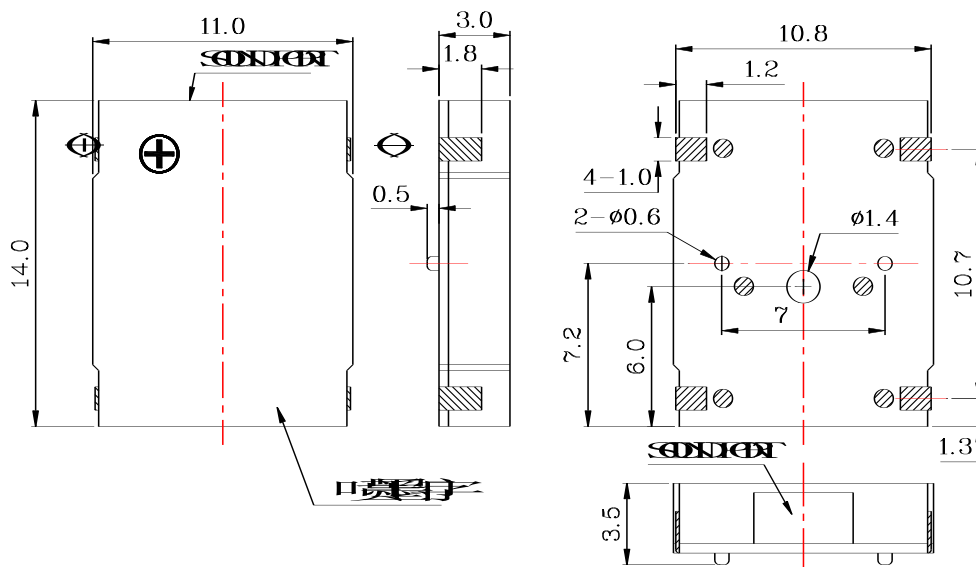

SMD-Signalgeber (ohne Ansteuerung) SMD-1411A05 Art.-Nr.: 220013

Test Method :

Standard Measurement conditions

Temperature: $25 \pm 2^\circ\text{C}$ Humidity: 45-65%

Acoustic Characteristics:

The oscillation frequency, current consumption and sound pressure are measured by the measuring instruments shown below

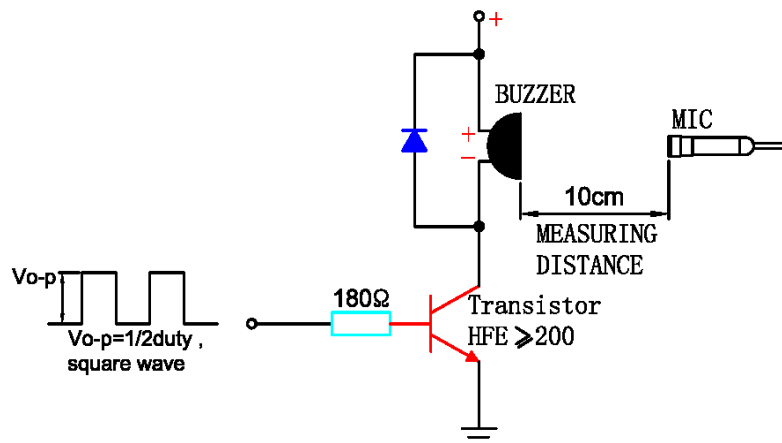

In the measuring test, buzzer is placed as follows:

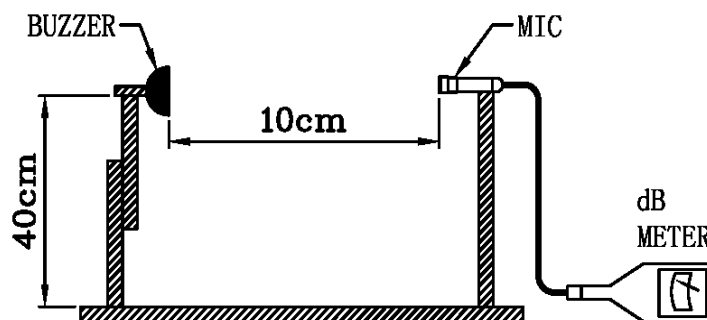

SMD-Signalgeber (ohne Ansteuerung) SMD-1411A05 Art.-Nr.: 220013

Typical Frequency Response Curve:

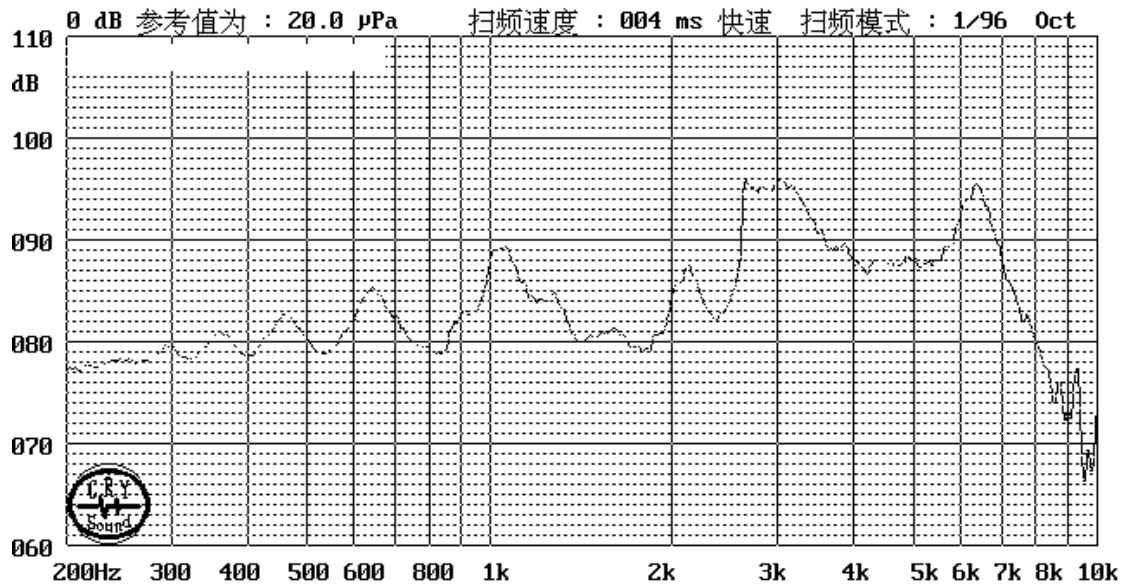

Recommend Driving Circuit :

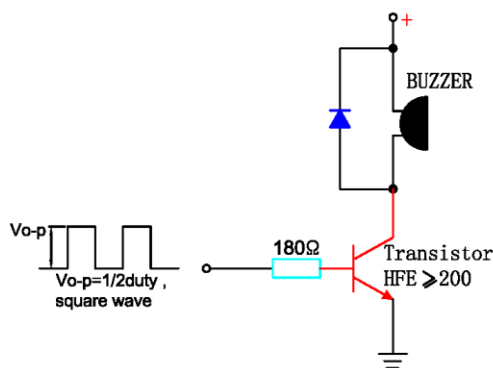

The base current I_b should high enough so that it saturates the collector current of the transistor with the CB load.

SMD-Signalgeber (ohne Ansteuerung) SMD-1411A05 Art.-Nr.: 220013

Reliability Test :

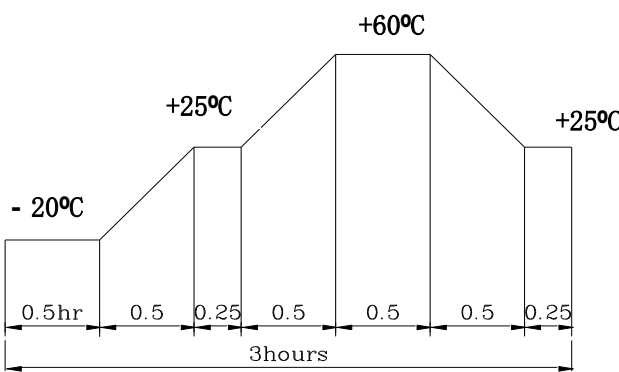
NO.	ITEM	TEST CONDITION AND REQUIREMENT
1	High Temperature Test (Storage)	After being placed in a chamber with 80 2°C for 96 hours and then being placed in normal condition for 2 hours. Allowable variation of SPL after test: 10dB.
2	Low Temperature Test (Storage)	After being Placed in a chamber with -30 2°C for 96 hours and then being placed in normal condition for 2 hours. Allowable variation of SPL after test: 10dB.
3	Humidity Test	After being Placed in a chamber with 90-95% R.H. at 40 2°C for 96 hours and then being placed in normal condition for 2 hours. Allowable variation of SPL after test: 10dB.
4	Temperature Cycle Test	<p>The part shall be subjected to 5 cycles. One cycle shall be consist of:</p>  <p>The diagram shows a temperature cycle profile over 3 hours. It starts at -20°C for 0.5 hours, then ramps up to +25°C in 0.5 hours, holds at +25°C for 0.25 hours, ramps up to +60°C in 0.5 hours, holds at +60°C for 0.5 hours, ramps down to +25°C in 0.5 hours, holds at +25°C for 0.25 hours, and finally ramps down to -20°C in 0.25 hours. The total duration is 3 hours.</p> <p>Allowable variation of SPL after test: 10dB.</p>
5	Drop Test	Drop on a hard wood board of 4cm thick, any directions ,6 times, at the height of 75cm . Allowable variation of SPL after test: 10dB.
6	Vibration Test	After being applied vibration of amplitude of 1.5mm with 10 to 55 Hz band of vibration frequency to each of 3 perpendicular directions for 2 hours . Allowable variation of SPL after test: 10dB.
7	Solderability Test	Lead terminals are immersed in rosin for 5 seconds and then immersed in solder bath of +300 5°C for 3 1 seconds . 90% min. lead terminals shall be wet with solder (Except the edge of terminals).
8	Terminal Strength Pulling Test	The force of 9.8N(1.0kg) is applied to each terminal in axial direction for 10 seconds. No visible damage and cutting off.

SMD-Signalgeber (ohne Ansteuerung) SMD-1411A05 Art.-Nr.: 220013

Soldering Condition :

(1) Recommendable reflow soldering condition is as follows

(Reflow soldering is twice)

Note: It is requested that reflow soldering should be executed after heat of product goes down to normal.

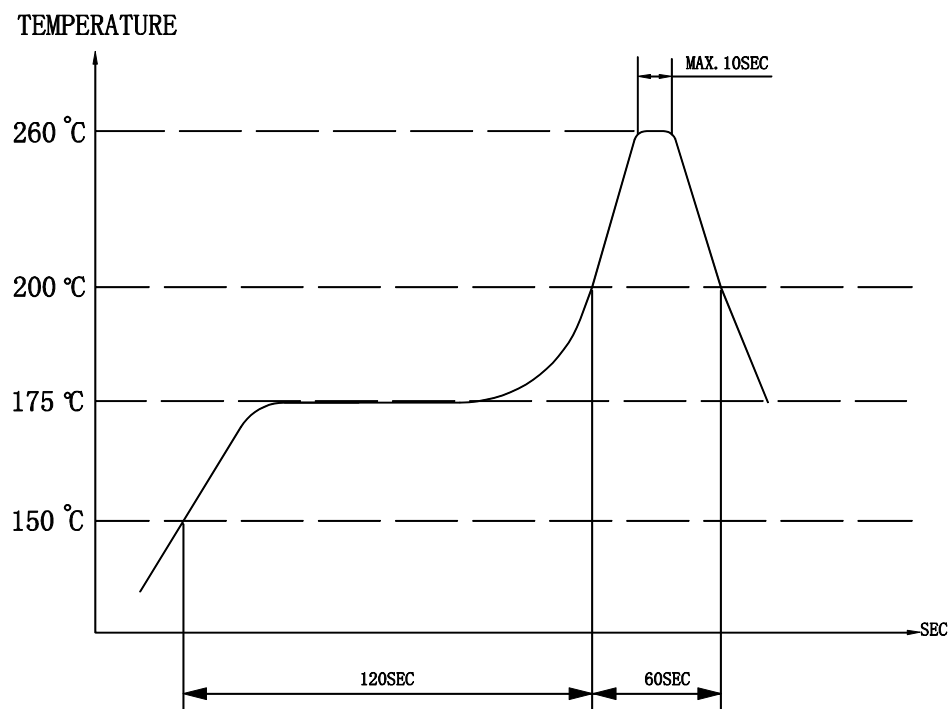

Heat resistant line

(Used when heat resistant reliability test is performed)

(2) Manual soldering

Manual soldering temperature 350 °C within 5 sec.

SMD-Signalgeber (ohne Ansteuerung) SMD-1411A05 Art.-Nr.: 220013

Packing:

