

SMD-Signalgeber (mit Ansteuerung) SMD-13D05 Art.-Nr.: 220036

Specification :

1	Rated Voltage (VDC)	5
2	Operating Voltage (VDC)	4~7
3	*Resonant Frequency (KHz)	2.4±0.4
4	*Sound Output at 10cm (dB)	≥85
5	*Current Consumption (mA)	≤30
6	Operating Temperature (°C)	-20~+70
7	Storage Temperature (°C)	-30~+80
8	Weight (g)	2.5
9	Housing Material	PPS

* Value applying at rated voltage (VDC) **Remark: The special requirements in the test for no anti reverse connection.**

Dimensions :

(Unit : mm)

Tolerance ± 0,5mm Except Specified

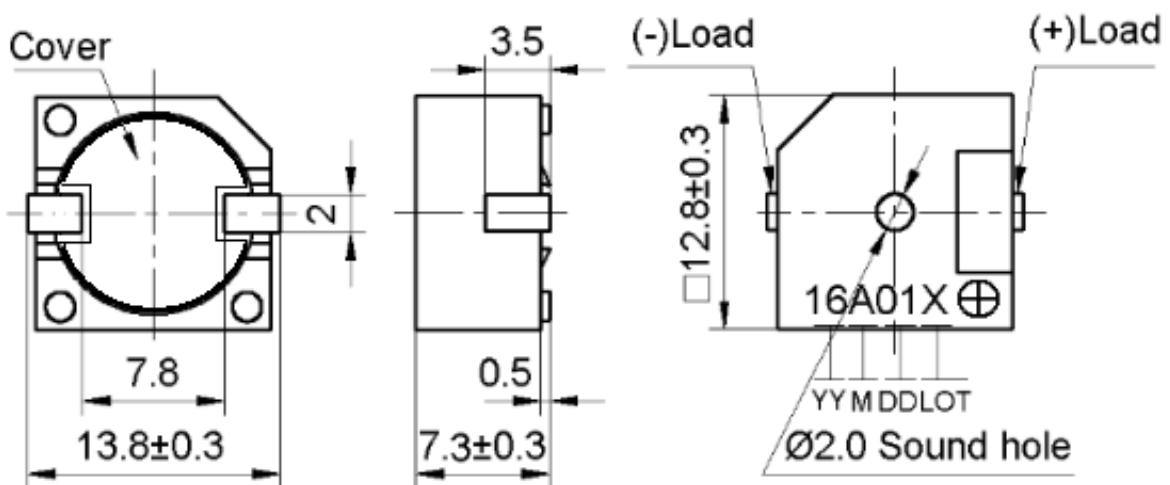

SMD-Signalgeber (mit Ansteuerung) SMD-13D05 Art.-Nr.: 220036

Test Method :

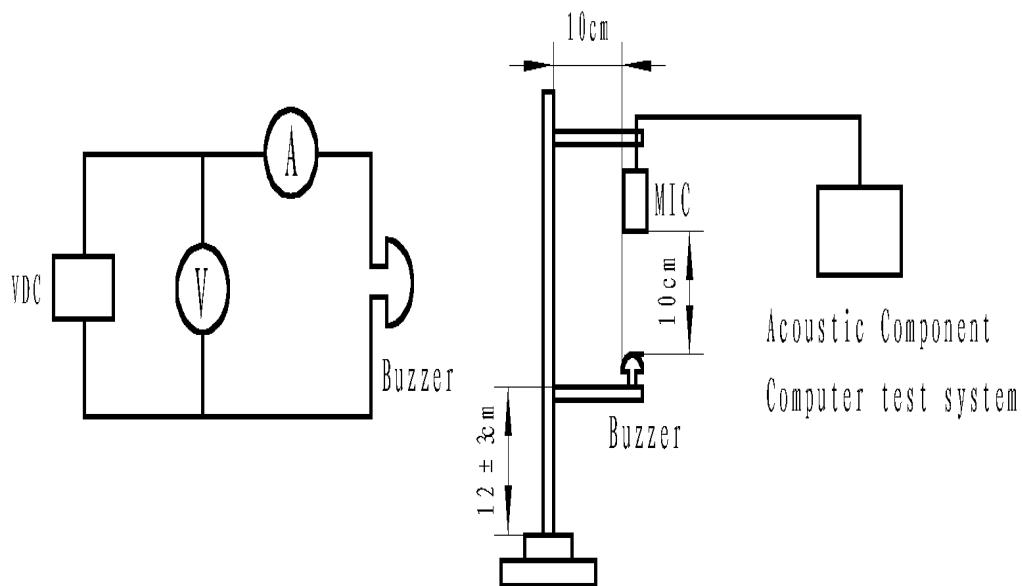

SMD-Signalgeber (mit Ansteuerung) SMD-13D05

Art.-Nr.: 220036

Reliably Test :

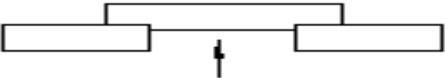
NO.	ITEM	TESTING CONDITION	VARIANCE AFTER TEST
1	High temp. storage life	The part shall be capable of withstanding a storage temperature is +80°C for 120 hours	After the test the part shall meet specifications without any degradation in appearance and performance except SPL shall be initial value ± 10dB or more.
2	Low temp. storage life	The part shall be capable of withstanding a storage temperature is -30°C for 120 hours	
3	Temp. Cycle	Total 5 cycles, 1 cycle consisting of -30±2°C, 30 minutes 20±5°C 15 minutes 80±2°C, 30 minutes 20±5°C 15 minutes	
4	Humidity Test	30±2°C, 90~95% RH, 120 hours	
5	Vibration Test	The part shall be subjected to a vibration cycle is 10Hz in a period of 1 minute. Total peak amplitude shall be 1.52mm(9.3g). The vibration test shall consist of 2 hours per plane in each three mutually perpendicular planes for a total time of 6 hours.	
6	Shock	Sounder shall be measured after being applied shock (980m/s ²) for each three mutually perpendicular directions to each of 3 times by half sine wave.	
7	Drop Test	Dropped naturally from 700mm height onto the surface of 10mm thick wooden board. 2 directions-upper and side of the part are to be applied.	
8	Lead pull	The part shall be pushed with a force of 9.8N for 10±1 seconds behind the part. 	After the test part shall meet specifications without any degradation in appearance and performance.
9	Recommended temp. Profile for Reflow Oven	Shown in Fig.1	

Warranty:For a period of one year from date of manufacture under normal operations.

SMD-Signalgeber (mit Ansteuerung) SMD-13D05 Art.-Nr.: 220036

Recommended Temp. Profile for Reflow Oven (Fig1) :

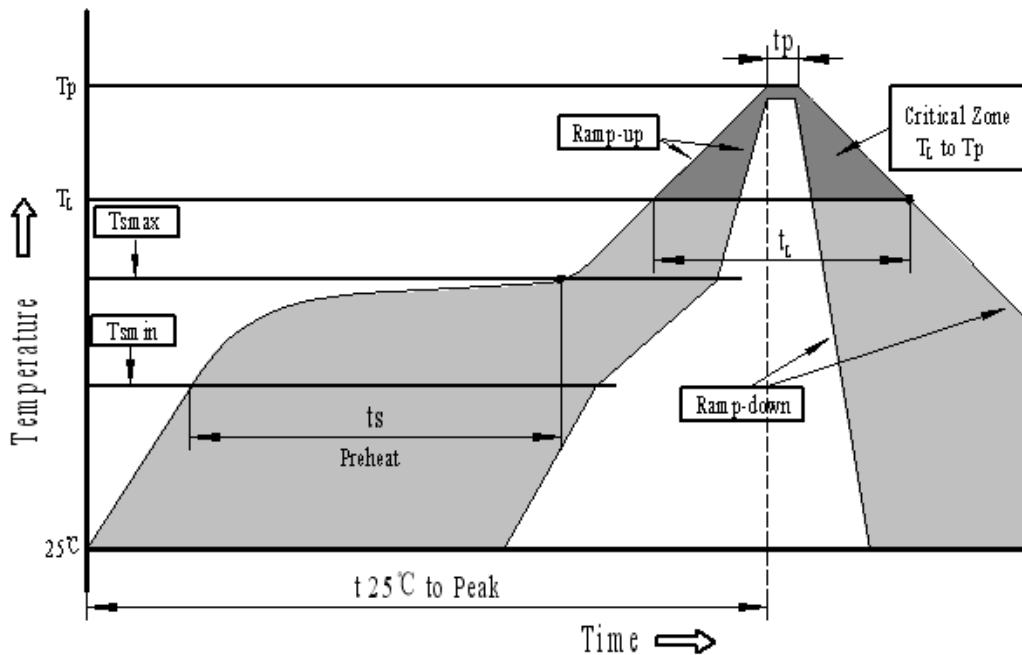

Profile Feature	Pb-Free Assembly
Average ramp-up rate(T _L to T _p)	3°C/second max.
Preheat	
-Temperature Min.(T _{Smin})	150°C
-Temperature Min.(T _{Smax})	200°C
-Temperature Min.(ts)	60~180 seconds
T _{Smax} to T _L	
-Ramp-up Rate	3°C/second max.
Time maintained above:	
- Temperature(T _L)	217°C
-Time(T _L)	60~150 seconds
Peak temperature(T _p)	245°C+0/-5°C
Time within 5°C of actual Peak temperature (tp)	6 seconds max.
Ramp-down Rate	6°C/second max.
Time 25°C to Peak Temperature	8 minutes max.

SMD-Signalgeber (mit Ansteuerung) SMD-13D05 Art.-Nr.: 220036

Packing :

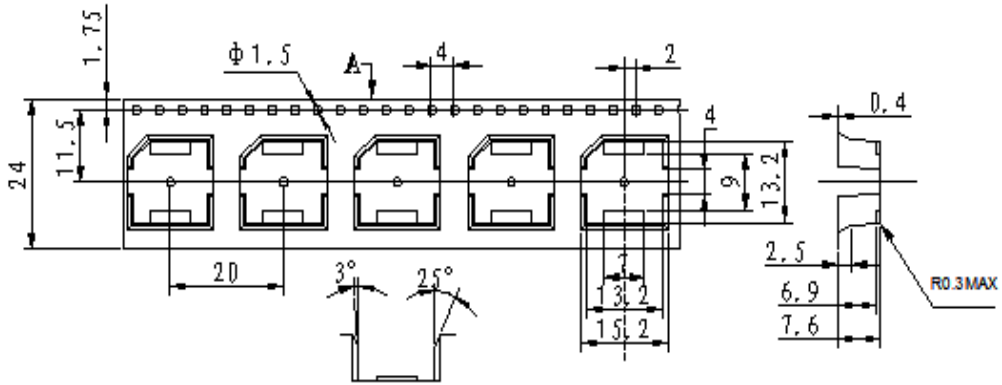

NOTE:

1. 10 sprocket hole pitch cumulative tolerance $\pm 0.2\text{mm}$.
2. All dimensions meet EIA-481-D requirements.
3. Thickness: $0.4 \pm 0.05\text{mm}$.
4. Component loaded per 13' reel: 450 pcs.

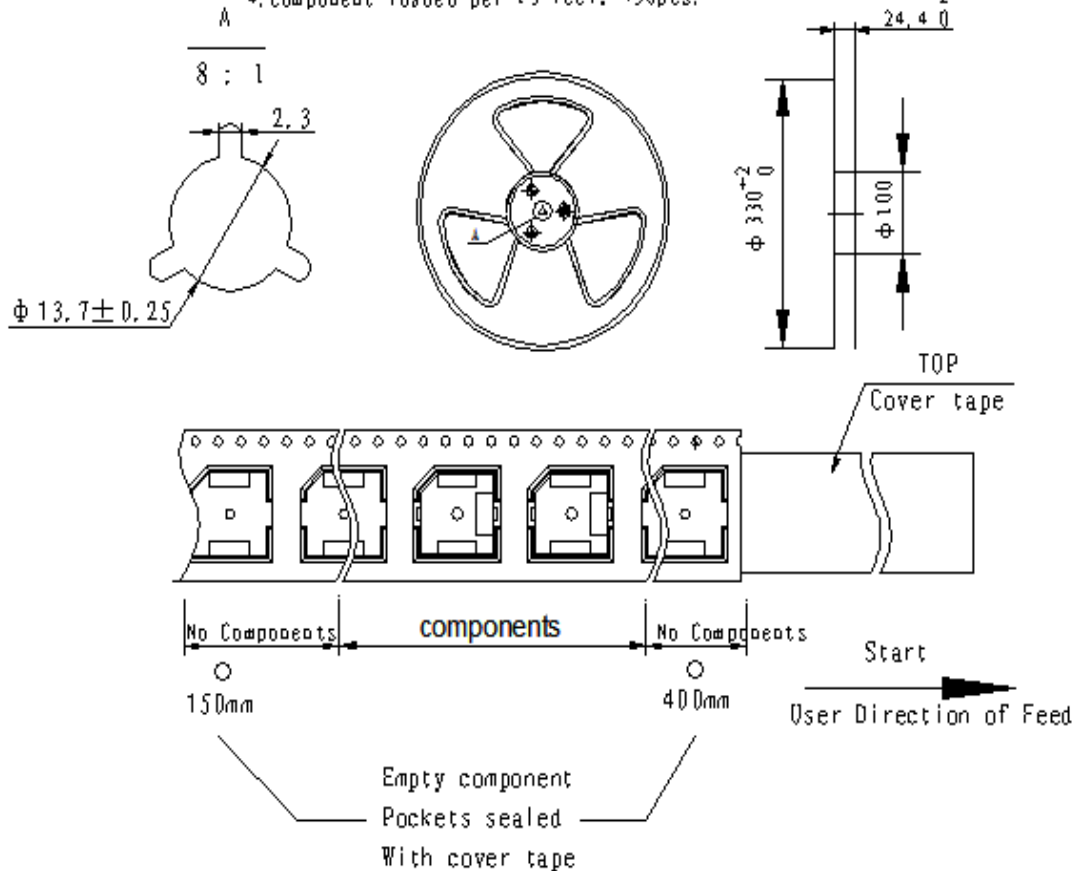

SMD-Signalgeber (mit Ansteuerung) SMD-13D05 Art.-Nr.: 220036

Packing :

