

The supplier acknowledges that, with the acceptance of the drawings, he is in a position to manufacture the illustrated part in accordance with the drawings in reproducible form and series production. Through the selected manufacturing processes and materials, which will arise in the material and structure which could subsequently lead to an impairment of the components. Verbal agreements over and above that are not valid. Deviations from this rule must be written and must be signed by the purchaser.

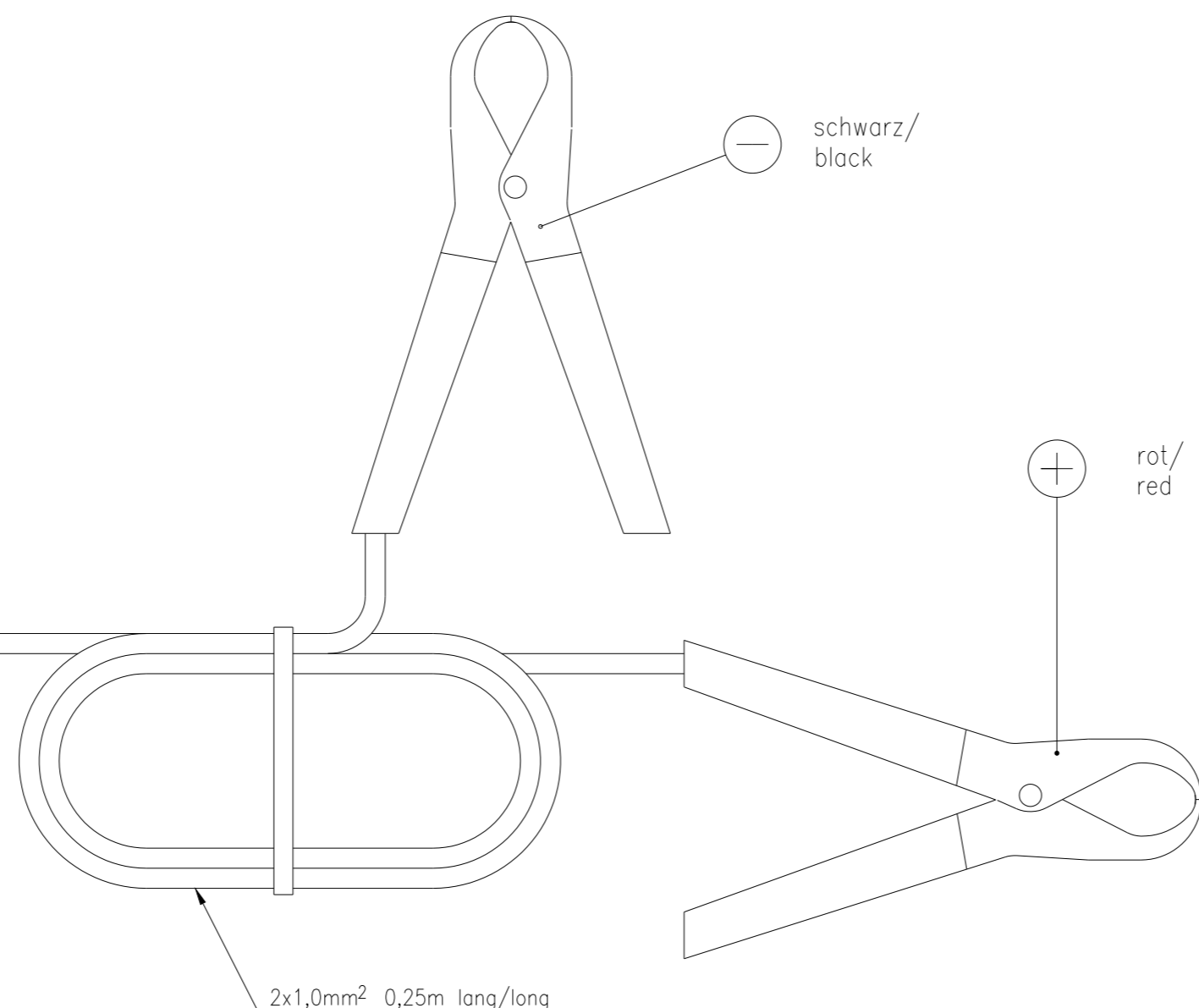
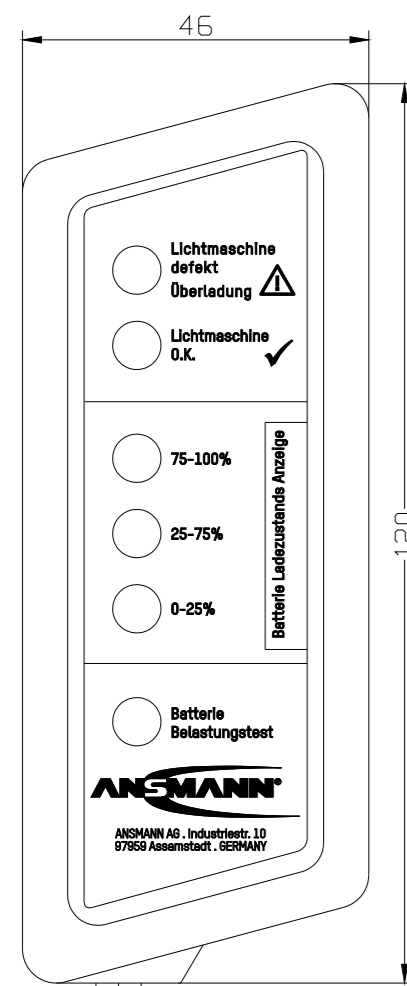

- Prüfung des Ladestromkreises der Lichtmaschine/ check of dynamo charging circuit
- Test des Ladezustandes der Batterie/ test of battery capacity
- Belastungstest der Batterie/ test of battery load
- Überwachung des Ladevorgangs mit ungeregelten Ladegeräten/ supervision of the charging process with unregulated chargers
- Geeignet für alle 12 V Kfz-Batterien/ suitable for all 12 V car batteries
- kurzschlussfest/ short-circuit proof
- Verpolschutz/ reverse-connect protection

Verpackung/ : Blisterverpackung 84x272x25mm
package blister package 84x272x25mm

Gewicht/ : 170g inkl. Zubehör und Verpackung
weight 170g incl. accessories and package

Approbation/ : CE
approvals

Lieferumfang/ : –mehrsprachige Bedienungsanleitung/
delivery multilingual operating instruction
–zusätzliche Aufkleber für Vorder.– und Rückseite in englisch, französisch und italienisch
additional labels for front. – and backside in english, france abd italian

English

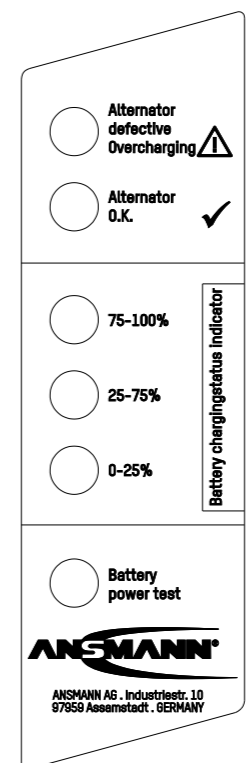

OPERATION
CHARGER REGULATOR TEST/ ALTERNATOR TEST
Switch off all electrical sources. Start the engine and change the motor speed. Switch on as many electrical sources as possible. Change the engine speed again.
CHARGER STATUS OF THE BATTERY
Switch on the headlights of the car for about 1 minute. Disconnect the battery and wait for around 15 minutes. Connect the red clip to the positive pole "+" and the black clip to the negative pole "-" of the battery.
BATTERY POWER TEST
Before starting the test, the battery has to be fully charged. Switch on all electrical sources such as blower, rear window heating, wipers, wipers, headlights and leave them on for about 3 minutes without starting the motor. Attention! When the green light goes out, stop the test immediately.
SUPERVISION BY EXTERNAL CHARGERS
Connect the Kfz-POWERCHECK to the battery to be charged. Use clip "-" black clip "-" and supervise the charging process. When the indicator "overcharging" lights, the charging process is completed. The battery has to be removed immediately from the charger.
Before putting into operation please read the instruction manual.
Art.Nr. / Part No. 4000002

Italian

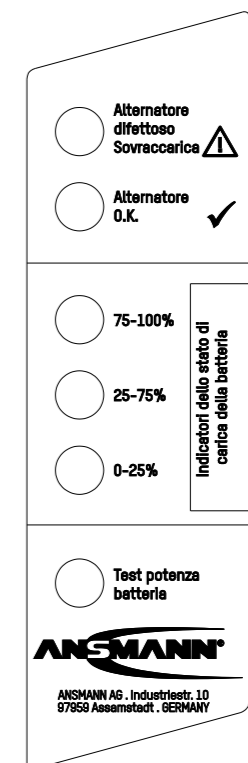

UTILIZZO
TEST REGOLAZIONE CARICA/TEST DELL'ALTERNATORE
Spegner tutti gli apparecchi di corrente. Accendere il motore e variare l'accelerazione del motore. Accendere gli utiizzi di corrente possibilmente. Variare nuovamente l'accelerazione del motore.
STATO DI CARICA DELLA BATTERIA
Accendere gli abbaglianti dell'auto per circa 1 minuto. Spostare la batteria e attendere circa 15 minuti. Collegare ora la pinza rossa con il polo "+" e la pinza nera con il polo "-" della batteria dell'auto.
TEST DELLA POTENZA DELLA BATTERIA
Prima di effettuare il test la batteria deve essere carica completamente. Accendere tutti gli apparecchi di corrente, come clacson, sbrinatori posteriori, tergicristallo, luci etc e utilizzarli per circa 3 minuti senza accendere il motore. Attenzione: se la luce verde si spegne, terminare immediatamente il test.
CONTROLLO DI CARICA BATTERIE ESTERNE
Collegare il Kfz-POWERCHECK alla batteria che deve essere caricata. Usare clip "-" pinza nera "-" e controllare il ciclo di carica. Quando l'indicatore "overcharging" si illumina, il ciclo di carica è completo e la batteria deve essere scollegata immediatamente dal caricabatteria.
Prima dell'utilizzo leggere per favore il manuale d'istruzione.
Art.Nr. / Part No. 4000002

France

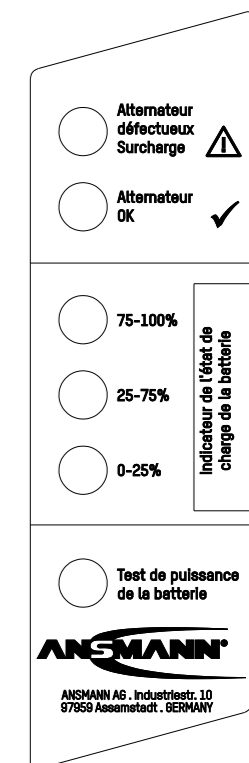

INSTRUCTIONS
TEST DU REGULATEUR DE CHARGE / DE L'ALTERNATEUR
Eteindre tous les appareils électriques. Démarrer le moteur et changer la vitesse de tours du moteur. Allumer en marche autant d'appareils électriques que possible. Changer la vitesse de tours du moteur.
TEST DE CHARGE DE LA BATTERIE
Mettre en marche les phares de la voiture pendant une minute. Débrancher ensuite la batterie de la voiture et attendre env. 15 minutes. Connecter la pince rouge sur le pôle positif "+" et la pince noire sur le pôle négatif "-".
TEST DE PUISSANCE DE LA BATTERIE
Recharger entièrement la batterie avant ce test. Allumer tous les appareils électriques" tout que la ventilation, le désembuage de la lunette arrière, essuie-glace, phares pendant 3 minutes sans allumer le moteur. Attention: si la lumière verte s'éteint, arrêter immédiatement l'essai de charge.
Lire les instructions d'utilisation avant l'usage.
Art.Nr. / Part No. 4000002

Application range for inquiry AN0314		Allowable deviation general tolerances		Surface	Model:	Material:	Weight:
V8	weight updated	21.09.15	SJT	DIN ISO 2768-m	Scale (DIN A2): 1:1	All dimensions in mm	Sheet 1/1
V8	label updated	02.06.15	SJT	2001	Date		
V7	"Made in China" added	06.04.10	MF	Drawn by	20.02	SP	Drawing name Kfz Power Check mit Klemmen Kfz Power Check with Clips
V6	backside printing modified	25.05.07	OB	Approved by			
V5	backside printing modified	09.11.04	SP				
V4	printing corrected	19.07.04	SP				
V3	weight added	13.11.03	OB				
V2	package added	29.01.03	SP				
V1	writing-head modified	23.10.01	SP				
Version	Change	Date	Name	Project: xx-xxxx-xxxxx	Replaced by:	Replacemnt through:	

