



# Technical Data Sheet

## Mini TOP View LEDs (Preliminary)

### 65-21/R7C-AP2Q2B/3T

#### Features

- White SMT package.
- Optical indicator.
- Wide viewing angle.
- Soldering methods: IR reflow soldering
- Available on tape and reel
- Pb-free
- The product itself will remain within RoHS compliant version.



#### Descriptions

The 65-21 series is available in soft orange, green, blue, and yellow. Due to the package design, the LED has wide viewing angle and optimized light coupling by inter reflector. Besides, LED is mounted top down and emits through the PCB. This feature makes the LED ideal for light pipe application.

#### Applications

- Optical indicators.
- Coupling into light guides.
- Backlighting (LCD, cellular phones, switches, keys, displays, illuminated advertising, general lighting).
- Coupling into light guides; Interior automotive lighting (e.g. dashboard backlighting, etc.).

#### Device Selection Guide

Chip		Lens Color
Material	Emitted Color	
AlGaInP	Dark- Red	Water Clear

**Package Outline Dimensions**

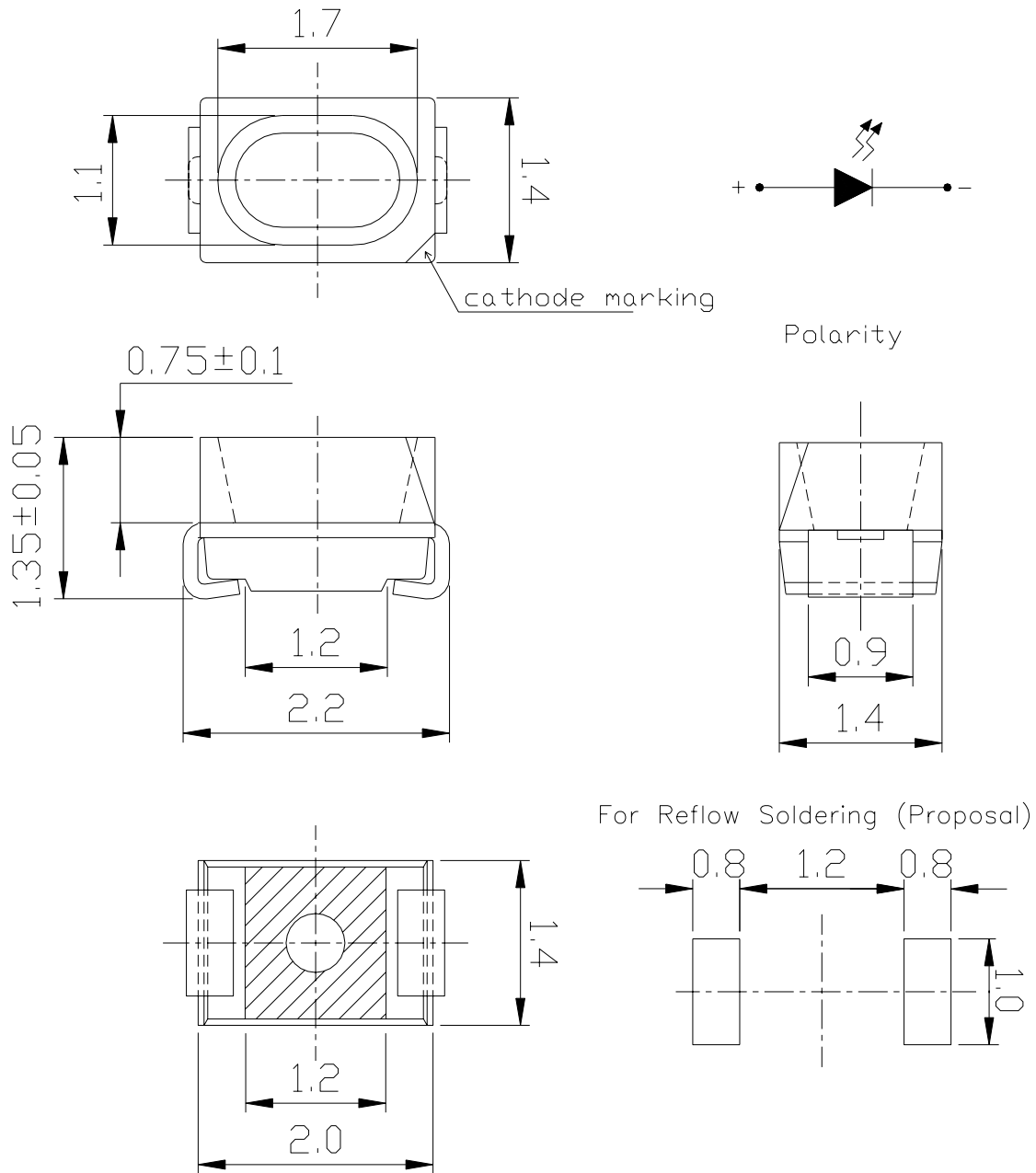

**Notes:** All dimensions are in millimeters.  
Tolerances unspecified are  $\pm 0.1$ mm.

**65-21/R7C-AP2Q2B/3T**
**Absolute Maximum Ratings (Ta=25°C)**

Parameter	Symbol	Rating	Unit
Reverse Voltage	V <sub>R</sub>	5	V
Forward Current	I <sub>F</sub>	25	mA
Operating Temperature	Topr	-40 ~ +100	°C
Storage Temperature	Tstg	-40 ~ +105	°C
Electrostatic Discharge (HBM)	ESD	2000	V
Power Dissipation	Pd	60	mW
Peak Forward Current (Duty 1/10 @1KHz)	I <sub>FP</sub>	60	mA
Soldering Temperature	Tsol	Reflow Soldering : 260 °C for 10 sec. Hand Soldering : 350 °C for 3 sec.	

**Electro-Optical Characteristics (Ta=25°C)**

Parameter	Symbol	Min.	Typ.	Max.	Unit	Condition
Luminous Intensity	I <sub>v</sub>	57	-----	112	mcd	I <sub>F</sub> =20mA
Viewing Angle	2θ 1/2	-----	120	-----	deg	
Peak Wavelength	λ <sub>p</sub>	-----	639	-----	nm	
Dominant Wavelength	λ <sub>d</sub>	625.5	-----	637.5	nm	
Spectrum Radiation Bandwidth	Δλ	-----	20	-----	nm	
Forward Voltage	V <sub>F</sub>	1.75	-----	2.35	V	
Reverse Current	I <sub>R</sub>	-----	-----	10	μA	V <sub>R</sub> =5V

**Notes:**

\*The luminous intensity data did not including ±10% testing tolerance.

\*Tolerance of forward voltage ±0.1V.

\*Tolerance of dominant wavelength ±1nm.

**65-21/R7C-AP2Q2B/3T****Bin Rang Of Dom. Wavelength**

Group	Bin	Min	Max	Unit	Condition
A	E6	625.5	629.5	nm	I <sub>F</sub> =20mA
	E7	629.5	633.5		
	E8	633.5	637.5		

**Bin Rang Of Luminous Intensity**

Bin	Min	Max	Unit	Condition
P2	57	72	mcd	I <sub>F</sub> =20mA
Q1	72	90		
Q2	90	112		

**Bin Range Of Forward Voltage**

Group	Bin	Min	Max	Unit	Condition
B	0	1.75	1.95	V	I <sub>F</sub> =20mA
	1	1.95	2.15		
	2	2.15	2.35		

## Notes:

\*The luminous intensity data did not including  $\pm 10\%$  testing tolerance.

\*Tolerance of forward voltage  $\pm 0.1V$ .

\*Tolerance of dominant wavelength  $\pm 1nm$ .

**65-21/R7C-AP2Q2B/3T**

**Typical Electro-Optical Characteristics Curves**

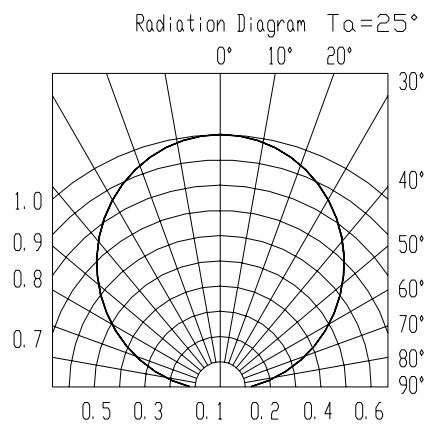
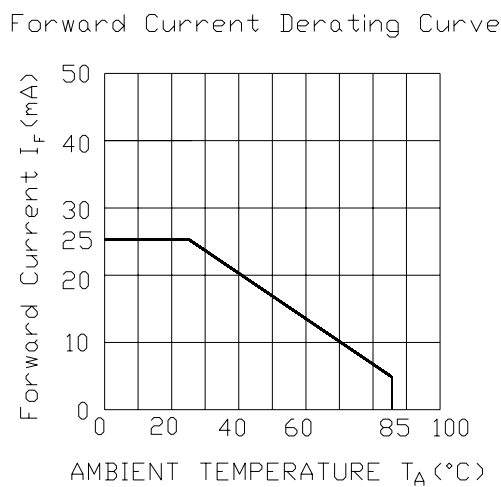
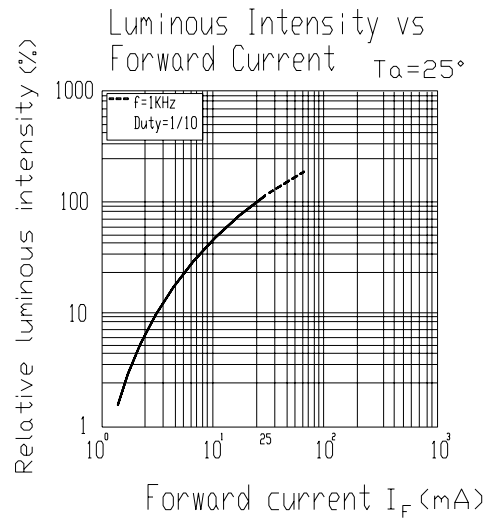
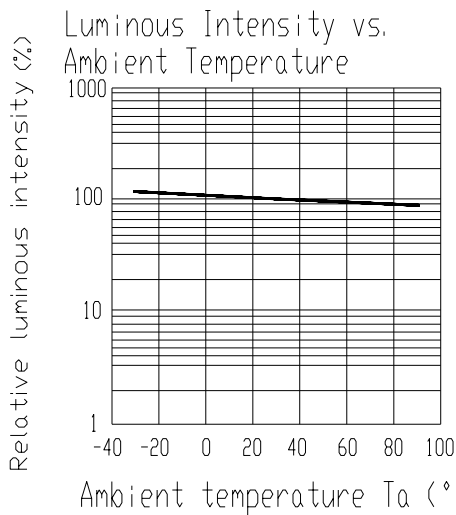
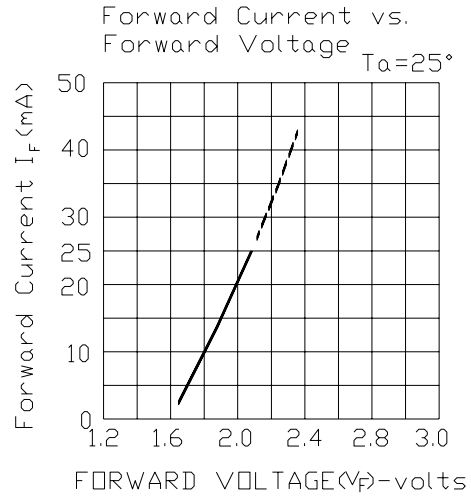
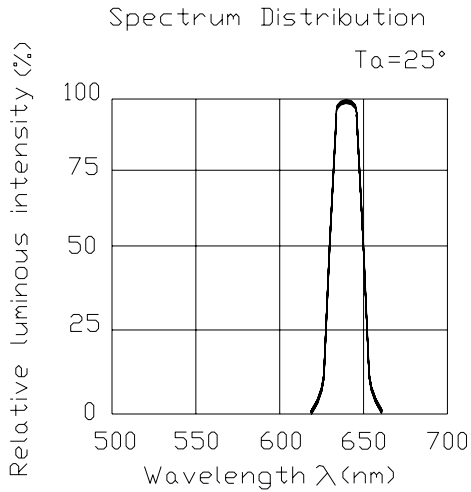

**Label explanation**

**CAT: Luminous Intensity Rank**

**HUE: Dom. Wavelength Rank**

**REF: Forward Voltage Rank**

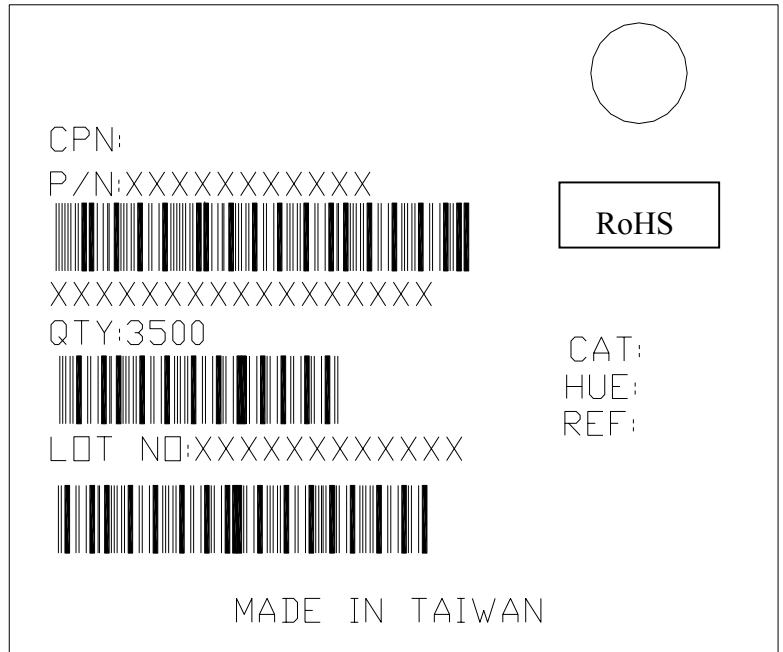

**Reel Dimensions**

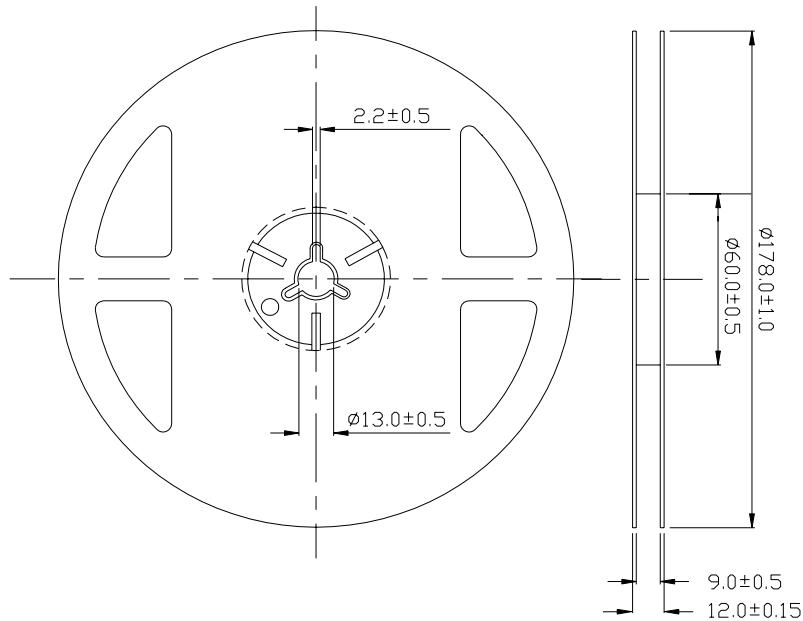

**Note:** The tolerances unless mentioned is ±0.1mm , Unit = mm

**Carrier Tape Dimensions: Loaded quantity per reel 3000 PCS/reel**

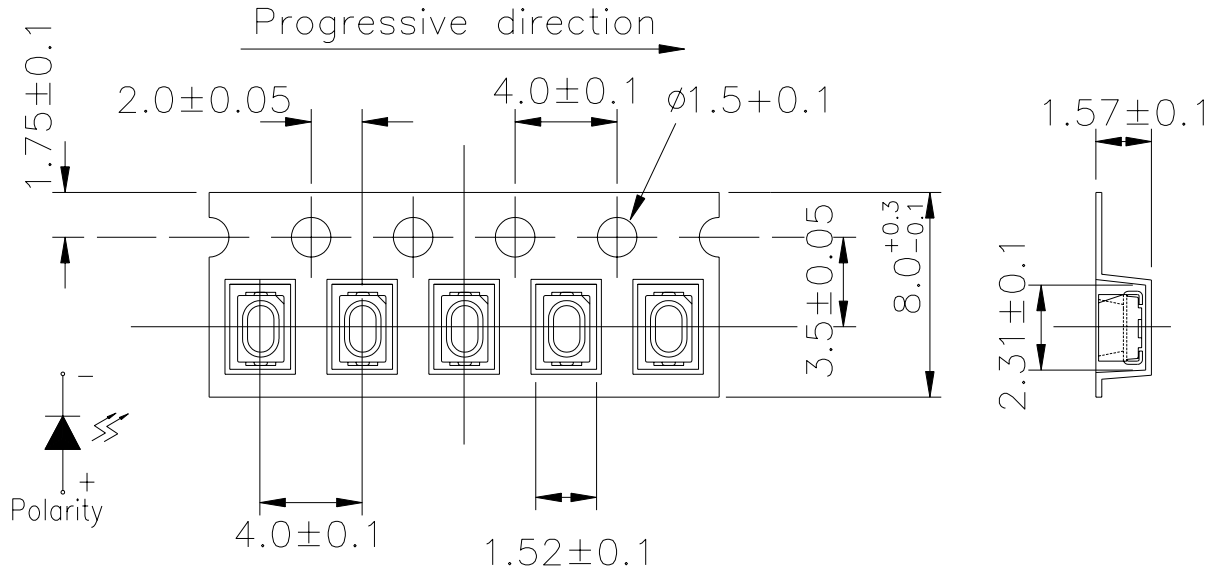

**Note:** The tolerances unless mentioned is  $\pm 0.1\text{mm}$  , Unit = mm

**Moisture Resistant Packaging**

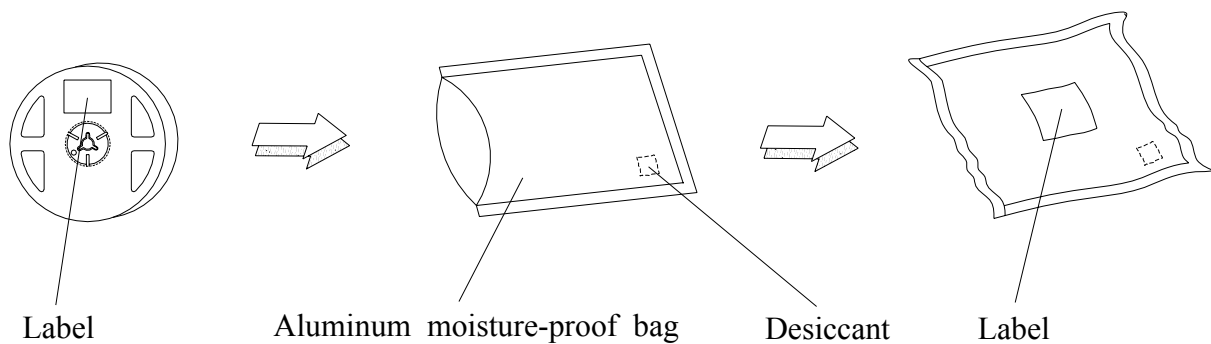

**65-21/R7C-AP2Q2B/3T****Reliability Test Items And Conditions**

The reliability of products shall be satisfied with items listed below.

Confidence level : 90%

LTPD : 10%

No.	Items	Test Condition	Test Hours/Cycles	Sample Size	Ac/Re
1	Reflow Soldering	Temp. : 260°C±5°C Min. 5sec.	6 min	22 PCS.	0/1
2	Temperature Cycle	H : +100°C 15min ∫ 5 min L : -40°C 15min	300 Cycles	22 PCS.	0/1
3	Thermal Shock	H : +100°C 5min ∫ 10 sec L : -10°C 5min	300 Cycles	22 PCS.	0/1
4	High Temperature Storage	Temp. : 100°C	1000 Hrs.	22 PCS.	0/1
5	Low Temperature Storage	Temp. : -40°C	1000 Hrs.	22 PCS.	0/1
6	DC Operating Life	I <sub>F</sub> = 20 mA	1000 Hrs.	22 PCS.	0/1
7	High Temperature / High Humidity	85°C/ 85%RH	1000 Hrs.	22 PCS.	0/1



**Precautions For Use**

## 1. Over-current-proof

Customer must apply resistors for protection, otherwise slight voltage shift will cause big current change ( Burn out will happen ).

## 2. Storage

2.1 Do not open moisture proof bag before the products are ready to use.

2.2 Before opening the package: The LEDs should be kept at 30°C or less and 90%RH or less.

2.3 After opening the package: The LED's floor life is 1 year under 30 deg C or less and 60% RH or less.

If unused LEDs remain, it should be stored in moisture proof packages.

2.4 If the moisture absorbent material (silica gel) has faded away or the LEDs have exceeded the storage time, baking treatment should be performed using the following conditions.

Baking treatment : 60±5°C for 24 hours.

## 3. Soldering Condition

## 3.1 Pb-free solder temperature profile

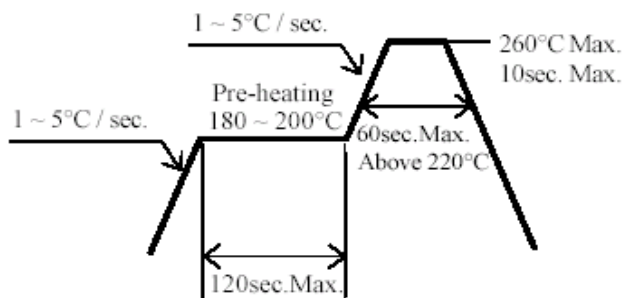

3.2 Reflow soldering should not be done more than two times.

3.3 When soldering, do not put stress on the LEDs during heating.

3.4 After soldering, do not warp the circuit board.

## 4. Soldering Iron

Each terminal is to go to the tip of soldering iron temperature less than 350°C for 3 seconds within once in less than the soldering iron capacity 25W. Leave two seconds and more intervals, and do soldering of each terminal. Be careful because the damage of the product is often started at the time of the hand solder.

### 5.Repairing

Repair should not be done after the LEDs have been soldered. When repairing is unavoidable, a double-head soldering iron should be used (as below figure). It should be confirmed beforehand whether the characteristics of the LEDs will or will not be damaged by repairing.

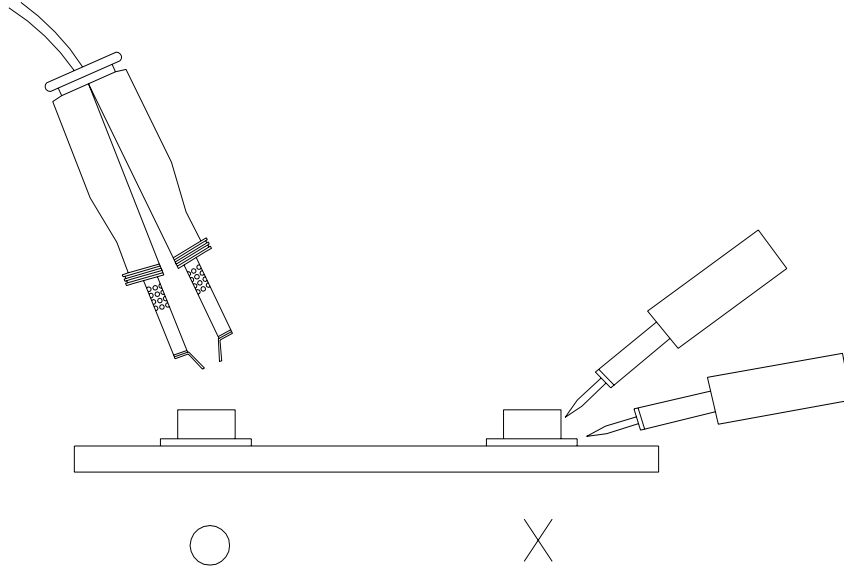

**EVERLIGHT ELECTRONICS CO., LTD.**

Office: No 25, Lane 76, Sec 3, Chung Yang Rd,  
Tucheng, Taipei 236, Taiwan, R.O.C

Tel: 886-2-2267-2000, 2267-9936

Fax: 886-2267-6244, 2267-6189, 2267-6306

<http://www.everlight.com>