

Product Specification	AEC Electronics Company Limited	Original Date	22/02/2019
		PN:	ACLTCV10.7BW950



AEC Electronics Company Limited
PRODUCT SPECIFICATION

Ceramic Filter

AEC PART NUMBER / SPEC. NO: ACLTCV10.7BW950

CUSTOMER: Schukat electronic Vertriebs GmbH



This model is ROHS compliance
according to the ROHS directive 2002/95/EC

Customer's Name	Schukat electronic Vertriebs GmbH
Production Name	Ceramic Filter
Frequency	10.7MHz
Model No	ACLTCV10.7BW950
Issue Date	21 st March, 2023

Address: Room 602-603, Java Commercial Centre,
128 Java Road,
North Point, Hong Kong
Homepage: <http://www.aeccrystal.com/>
Email: sales@aeccrystal.com
Telephone: (852)-2856 0000
Fax (852) 2561 2161

Prepared	Inspection	Approved
<i>Nathan</i>	<i>Andy</i>	<i>Henkie</i>

Product Specification	AEC Electronics Company Limited	Original Date	22/02/2019
		PN:	ACLTCV10.7BW950

1 · SCOPE

This specification shall cover the characteristics of the ceramic filter with the type ACLTCV10.7BW950

2 · PART NO.

PART NUMBER
ACLTCV10.7BW950
CUSTOMER PART NO

3 · OUTLINE DIMENSIONS AND MARK

3.1 Appearance: No visible damage and dirt.

3.2 Construction: SMD ceramic packaging.

3.3 The products conform to the RoHS directive and national environment protection law.

3.4 Dimensions and mark

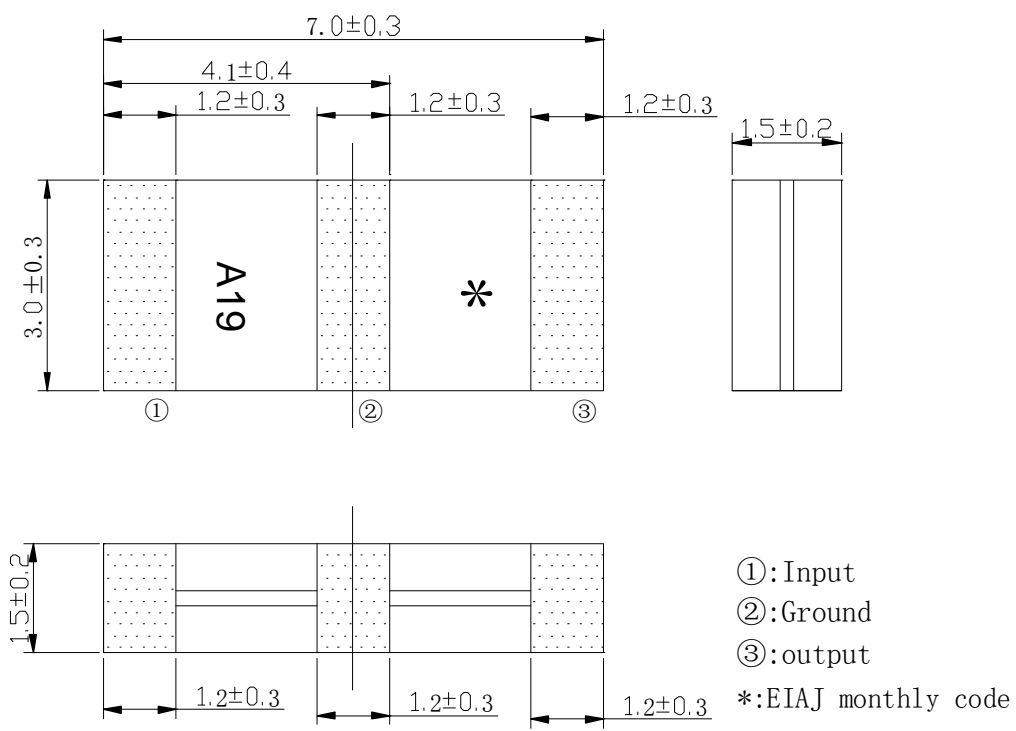

3.5 Structure

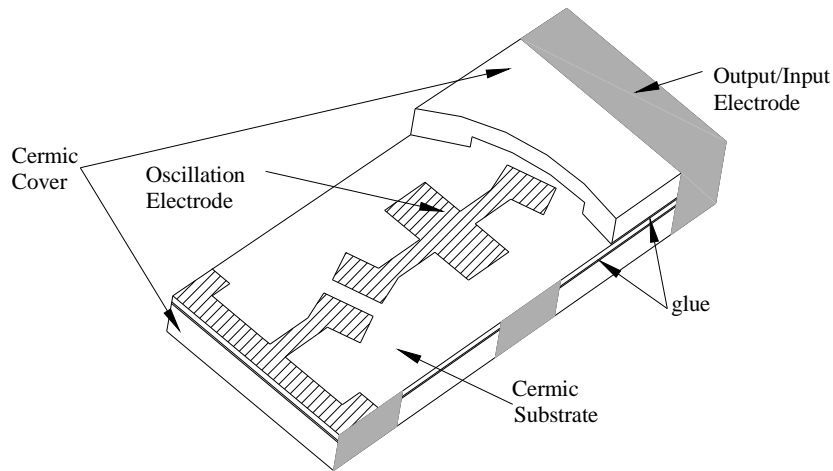

4 ELECTRICAL SPECIFICATIONS

4.1 RATING

Items	Content
Withstanding Voltage (V)	50 (DC · 1min)
Insulation Resistance Ri, (MΩ) min.	100 (10V · 1min)
Operating Temperature Range (°C)	-20~+80
Storage Temperature Range (°C)	-40~+85

4.2 ELECTRICAL SPECIFICATIONS

Items	Content
Center Frequency(fo)(MHz)	10.700±0.030
3dB Bandwidth(kHz)	fn±175
20dB Bandwidth(kHz) max	950
Insertion Loss (dB)	3.0±2.0 (at minimum loss point)
Ripple (dB) max	3.0 (within 3dB Bandwidth)
Spurious Attenuation (dB) min	20 (5MHz-15MHz)
Input/Output Impedance(Ω)	470
Temp. Characteristic	±0.5% (-20°C to 80°C)

5 · TEST

5.1 Test Conditions

Parts shall be tested under the condition (Temp. : 20±15°C, Humidity : 65±20% R.H.) unless the standard condition(Temp. : 25±2°C, Humidity : 65±5% R.H.)

is regulated to measure.

5.2 Test Circuit

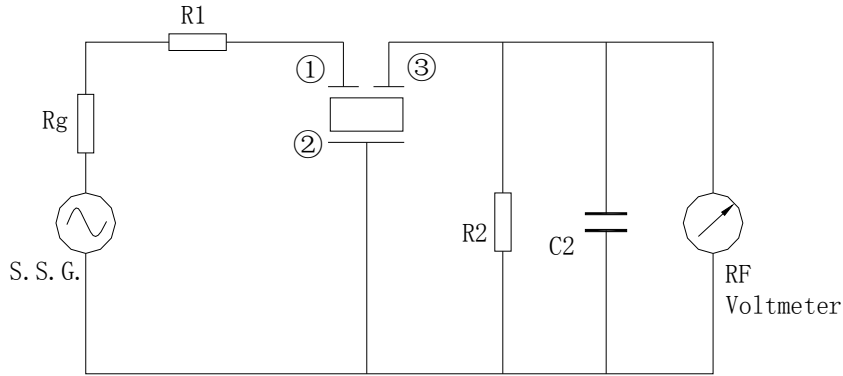

$R1=420\Omega\pm5\%$, $R2=470\Omega\pm5\%$, $Rg=50\Omega$ ①:Input
 $C2=10\text{ Pf}$ (Including stray capacitance and capacitance of RF Voltmeter) ②:Ground
S.S.G:Output Voltmeter ③:Output

6 · ENVIRONMENTAL TEST

No.	Item	Condition of Test	Performance Requirement	
6.1	Humidity	Subject the filter at $40\pm 2^{\circ}\text{C}$ and 90%-95% R.H. for 96h, Filter shall be measured after being placed in natural conditions for 1h.	It shall fulfill Table 1.	
6.2	High Temperature Exposure	Subject the filter to $85\pm 2^{\circ}\text{C}$ for 96h, Filter shall be measured after being placed in natural conditions for 1h.	It shall fulfill Table 1.	
6.3	Low Temperature Exposure	Subject the filter to $-40\pm 2^{\circ}\text{C}$ for 96h, Filter shall be measured after being placed in natural conditions for 1h.	It shall fulfill Table 1.	
6.4	Temperature Cycling	After temperature cycling of blow table was performed 5 times, Filter shall be measured after being placed in natural conditions for 1h.	It shall fulfill Table 1.	
		Temperature		Time
		$-20\pm 3^{\circ}\text{C}$		30 ± 3 min
		$80\pm 3^{\circ}\text{C}$		30 ± 3 min
6.5	Vibration	Subject the filter to vibration for 2h. Each in x y and z axis with the amplitude of 1.5mm, The frequency shall be varied uniformly between the limits of 10Hz-55Hz-10Hz and then filter shall be measured.	It shall fulfill Table 1.	
6.6	Mechanical Shock	Filter shall be measured after 3 times random dropping from the height of 1m on wooden plate.	No visible damage and it shall fulfill Table 1.	
6.7	Soldering Test	<p>Passed through the re-flow oven under the following condition and left at room temperature for 24h before measurement.</p>	It shall fulfill Table 1.	

(to be continued)

6 · ENVIRONMENTAL TEST

No.	Item	Condition of Test	Performance Requirements
6.8	Solderability	Dipped in 235°C±5°C solder bath for 3s±0.5s with rosin flux (25wt% ethanol solution.)	The terminals shall be at least 95% covered by solder.
6.9	Board Bending	<p>Mount on a glass-epoxy board(width =50mm, thickness=1.6mm),then bend it to 1mm displacement(velocity= 1mm/s) and keep it for 5s.</p>	Mechanical damage such as break shall not occur

Table 1

Item	Characteristics after test
Center Frequency Drift (kHz) max	±30
Insertion Loss Drift (dB) max	±2
3dB Bandwidth Drift (kHz) max	±25
20dB Bandwidth Drift (kHz) max	±60
Note:The limits in the above table are referenced to the initial measurements.	

7 RECOMMENDED LAND PATTERN AND REFLOW SOLDERING STANDARD CONDITIONS

7.1 Recommended land pattern

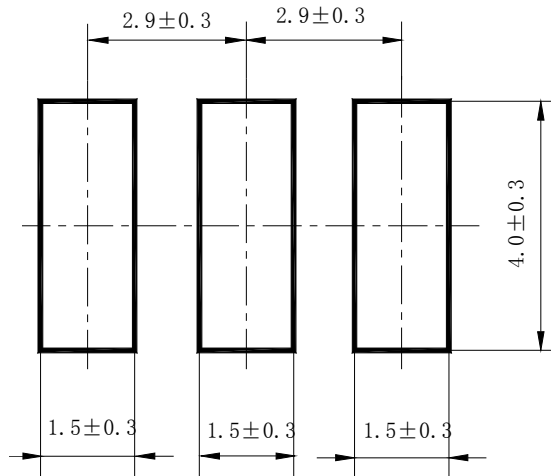

7.2 Recommended reflow soldering standard condition

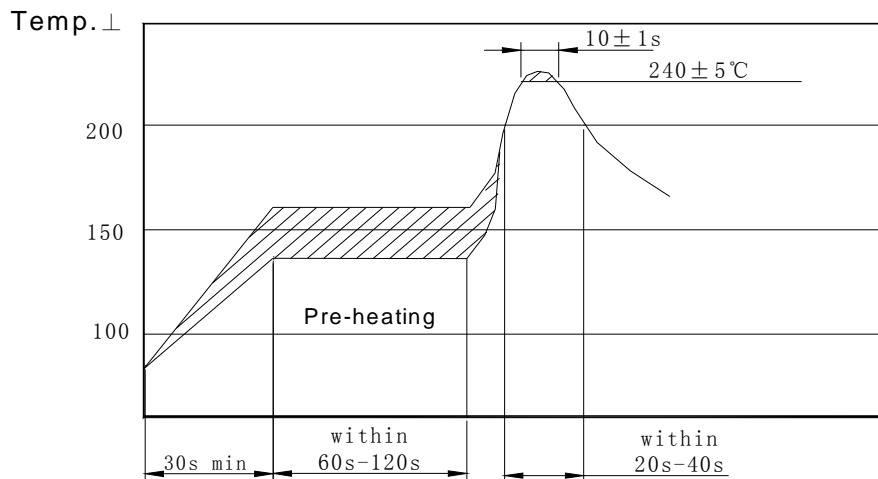

Product Specification	AEC Electronics Company Limited	Original Date	22/02/2019
		PN:	ACLTCV10.7BW950

8 · PACKAGE

To protect the products in storage and transportation , it is necessary to pack them (outer and inner package) .

8.1 On paper pack, the following requirements are requested.

8.1.1 Dimensions and Mark

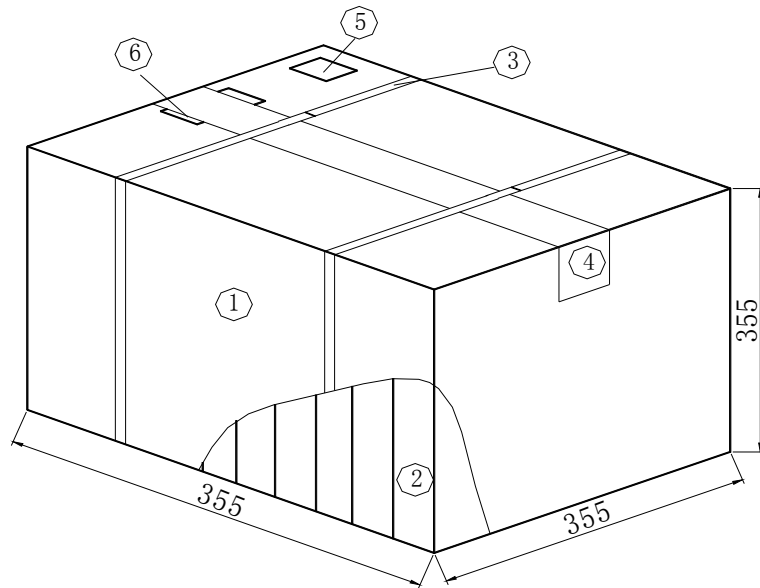

NO.	Name	Quantity
①	Package	1
②	Inner Box	10
③	Belt	2.9 m
④	Adhesive tape	1.2 m
⑤	Label	1
⑥	Certificate of approval	1

8.1.2 Section of package

Package is made of corrugated paper with thickness of 0.8cm. Package has 10 inner boxes, each box has 1 reels (each reel for plastic bag).

8.1.3 Quantity of package

Per plastic reel 4000 pieces of piezoelectric ceramic part

Product Specification	AEC Electronics Company Limited	Original Date	22/02/2019
		PN:	ACLTCV10.7BW950

Per inner box 1 reel
Per package 10 inner boxes
(40000 pieces of piezoelectric ceramic part)

8.1.4 Inner Box Dimensions

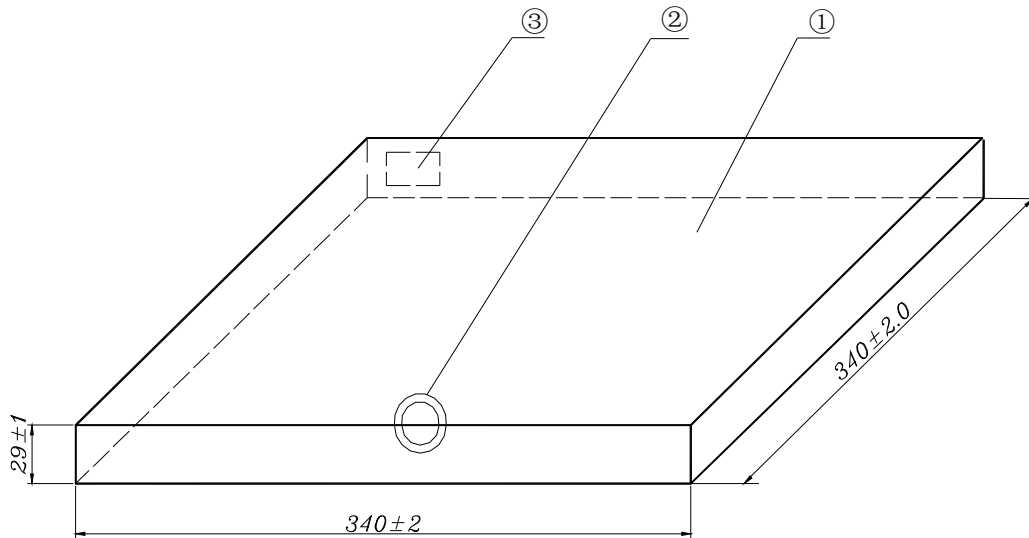

NO.	Name	Quantity
①	Inner Box	1
②	QC Label	1
③	Label	1

8.2 On reel pack, the following requirements are requested.

8.2.1 Reel

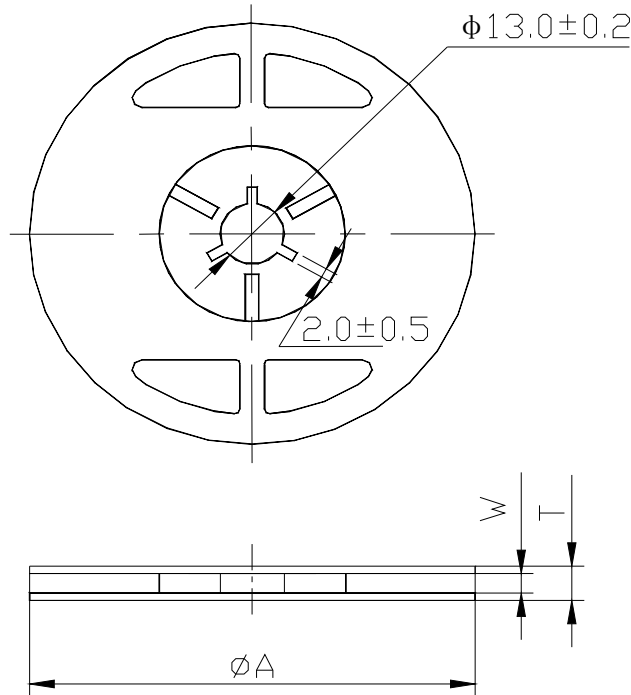

ϕA	W	T	Pieces per reel	Carrier tape size
330±3	16.4min	22.4max	4000typ.	16

8.2.3 Packing Method Sketch Map

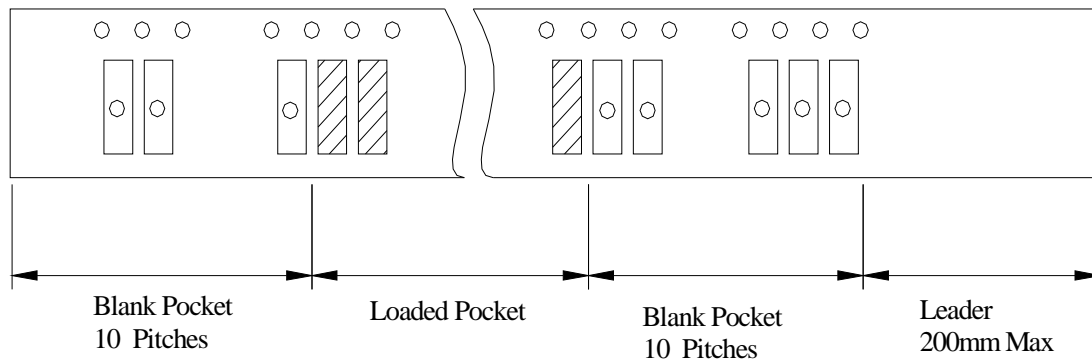

8.2.4 Test Condition Of Peeling Strength

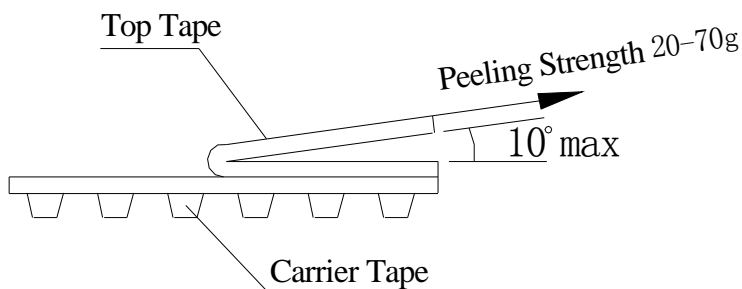

Product Specification	AEC Electronics Company Limited	Original Date	22/02/2019
		PN:	ACLTCV10.7BW950

9 · EIAJ Monthly Code

2017/2019/2021/2023		2018/2020/2022/2024	
MONTH	CODE	MONTH	CODE
JAN	A	JAN	N
FEB	B	FEB	P
MAR	C	MAR	Q
APR	D	APR	R
MAY	E	MAY	S
JUN	F	JUN	T
JUL	G	JUL	U
AUG	H	AUG	V
SEP	J	SEP	W
OCT	K	OCT	X
NOV	L	NOV	Y
DEC	M	DEC	Z

10 · OTHER

10.1 Caution

10.1.1 Don't apply excess mechanical stress to the component and terminals at soldering. Do not use this product with bend.

10.1.2 Do not clean or wash the component for it is not hermetically sealed.

10.1.3 Do not use strong acidity flux , more than 0.2wt% chlorine content , in flow soldering.

10.1.4 Don't be close to fire.

10.1.5 This specification mentions the quality of the component as a single unit. Please insure the component is thoroughly evaluated in your application circuit

10.1.6 Expire date (Shelf life) of the products is 12 months after delivery under the conditions of a sealed and an unopened package. Please use the products within 12 months after delivery. If you store the products for a long time (more than 12 months), use carefully because the products may be degraded in the solder-ability or rusty. Please confirm solder-ability and characteristics for the products regularly.

10.1.7 Exposure components under soldering condition that is exceeding our recommendation will increase the failure dangerous.

10.1.8 Please contact us before using the product as automobile electronic component.

10.2 Notice

10.2.1 Please return one of these specifications after your signature of acceptance.

10.2.2 When something gets doubtful with this specifications, we shall jointly work to get an agreement.