

DISPLAY Elektronik GmbH

DATA SHEET

LCD MODULE

DEM 16224 SYH

Product Specification

Version: 4

05.09.2022

GENERAL SPECIFICATION

MODULE NO. :

DEM 16224 SGH

CUSTOMER P/N

VERSION NO.	CHANGE DESCRIPTION	DATE
0	ORIGINAL VERSION	26.03.2001
1	UPDATE MODULE DRAWING AND CHARACTER GENERATOR ROM	04.04.2001
2	ADD VERSION	14.04.2003
2.1.1	CHANGE IC (SPLC783A1)	24.10.2008
2.1.1.1	CHANGE IC (ST7066U-0A)	06.07.2017
2.2	ADD PCB DRAWING	22.09.2017
3	UPDATE THE MODULE DRAWING	24.08.2022
4	UPDATE THE MODULE DRAWING	05.09.2022

PREPARED BY: LM

DATE: 05.09.2022

APPROVED BY: MH

DATE: 05.09.2022

CONTENTS

1.FUNCTIONS & FEATURES2

2. MECHANICAL SPECIFICATIONS.....2

3. EXTERNAL DIMENSIONS3

4. BLOCK DIAGRAM.....4

5. PIN ASSIGNMENT.....4

6. PCB DRAWING5

7. MAXIMUM ABSOLUTE LIMIT6

8. ELECTRICAL CHARACTERISTICS6

9. DISPLAY DATA RAM (DDRAM)8

10. INSTRUCTION TABLE.....9

11. LCM INITIALIZING BY INSTRUCTION10

12. CHARACTER GENERATOR ROM12

13. MODULE ACCEPT QUALITY LEVEL (AQL)13

14. RELIABILITY TEST13

15. QUALITY DESCRIPTION14

16. LCD MODULES HANDLING PRECAUTIONS.....15

17. OTHERS15

1.

FUNCTIONS & FEATURES

MODULE NAME	LCD TYPE
DEM 16224 SYH	STN Yellow-Green Reflective Positive Mode

- Viewing Direction : 6 O'clock
- Driving Scheme : 1/16 Duty Cycle, 1/5 Bias
- Power Supply Voltage : 5.0 Volt (typ.)
- V_{LCD} (VDD-V0) : 4.5 Volt (typ.)
- Display Format : 16 Characters x 2 line
- Internal Memory : CGROM (13200bits)
: CGRAM (64 x 8bits)
: DDRAM (80 x 8 bits for Digits)
- CGROM : CGROM of the ST7066U-0A
- Interface : Easy Interface with a 4-bit or 8-bit MPU

2. MECHANICAL SPECIFICATIONS

- Module Size : 66.60 x 23.30 x 2.85 mm
- Character Pitch : 3.55 x 6.30 mm
- Character Size : 2.95 x 5.55 mm
- Character Font : 5 x 8 dots
- Dot Size : 0.55 x 0.65 mm
- Dot Pitch : 0.60 x 0.70 mm

3. EXTERNAL DIMENSIONS

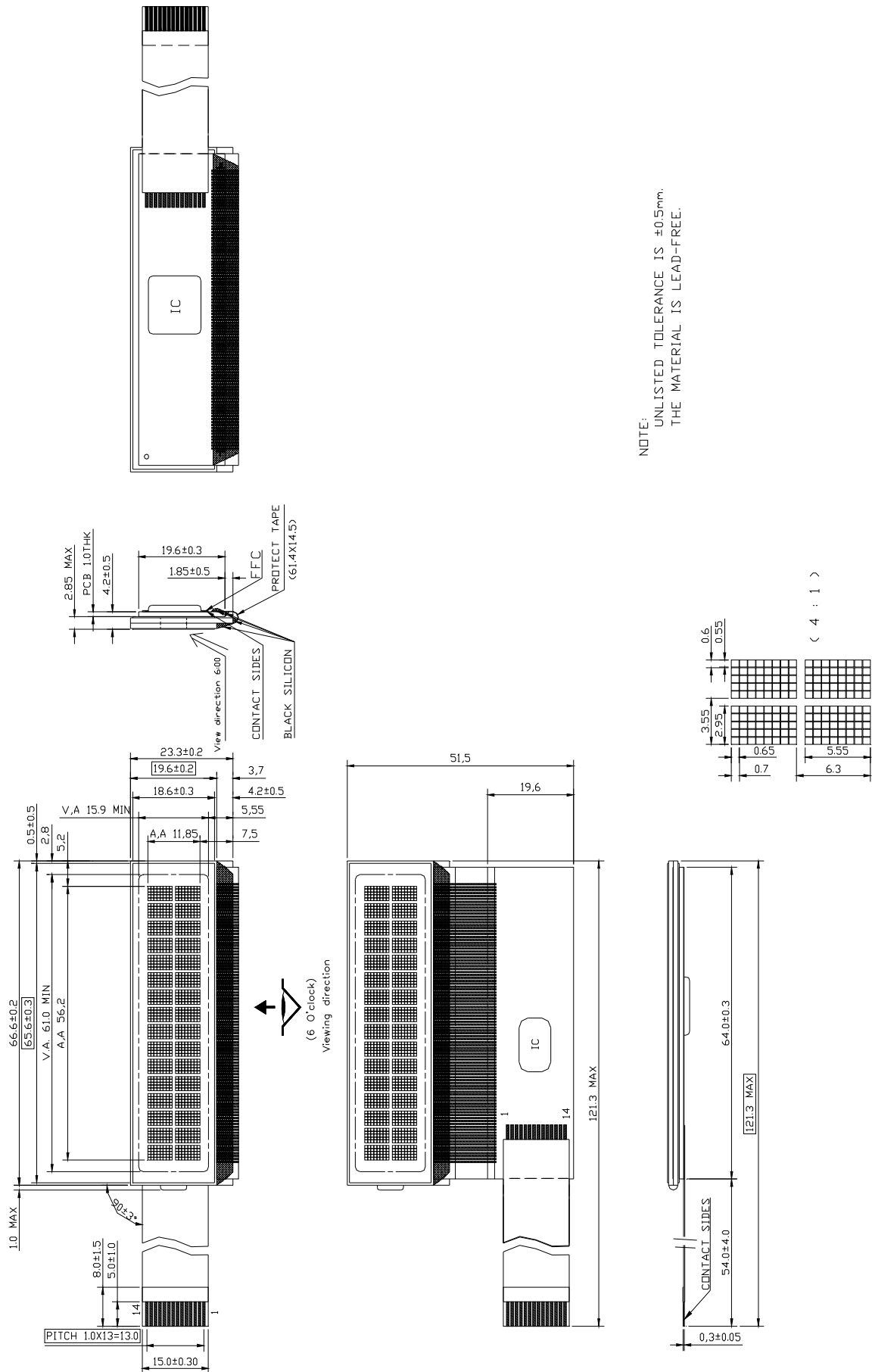

4. BLOCK DIAGRAM

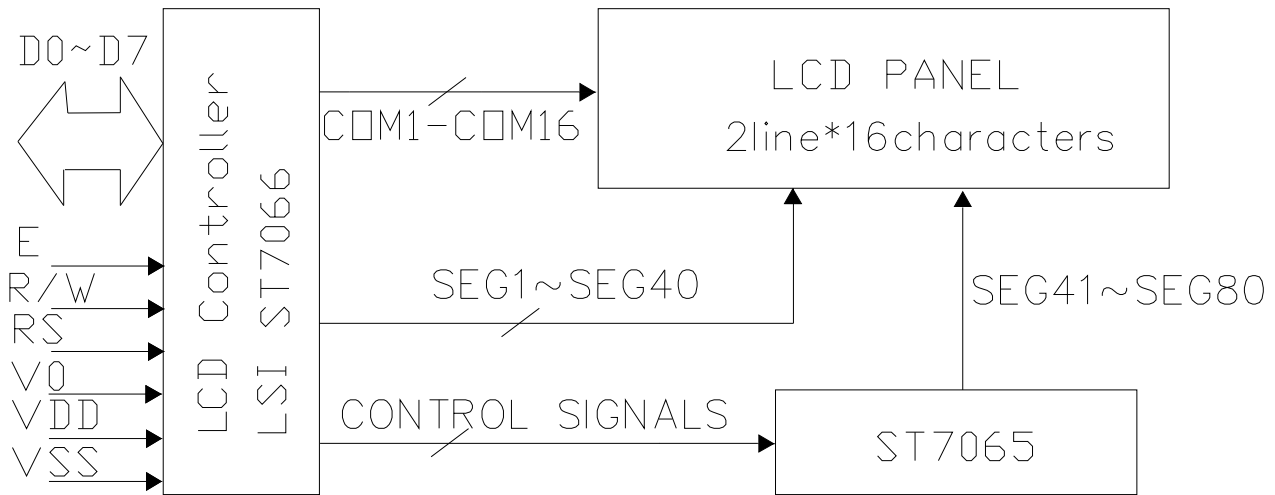

5. PIN ASSIGNMENT

Pin No.	Symbol	Function
1	VDD	Supply terminal of module 5.0 V
2	V0	Power Supply for Liquid crystal Drive
3	RS	Register select RS = 0 (Instruction register) RS = 1 (Data register)
4	R/W	Read /Write R/W = 1 (Read) R/W = 0 (Write)
5	E	A start signal for reading or writing data
6	DB0	Bi-directional data bus, data transfer is performed once, thru DB0 to DB7, in the case of interface data. Length is 8-bits; and twice, thru DB4 to DB7 in the case of interface data length is 4-bits. Upper four bits first then lower four bits.
7	DB1	
8	DB2	
9	DB3	
10	DB4	
11	DB5	
12	DB6	
13	DB7	
14	VSS	Ground terminal of module

6. PCB DRAWING

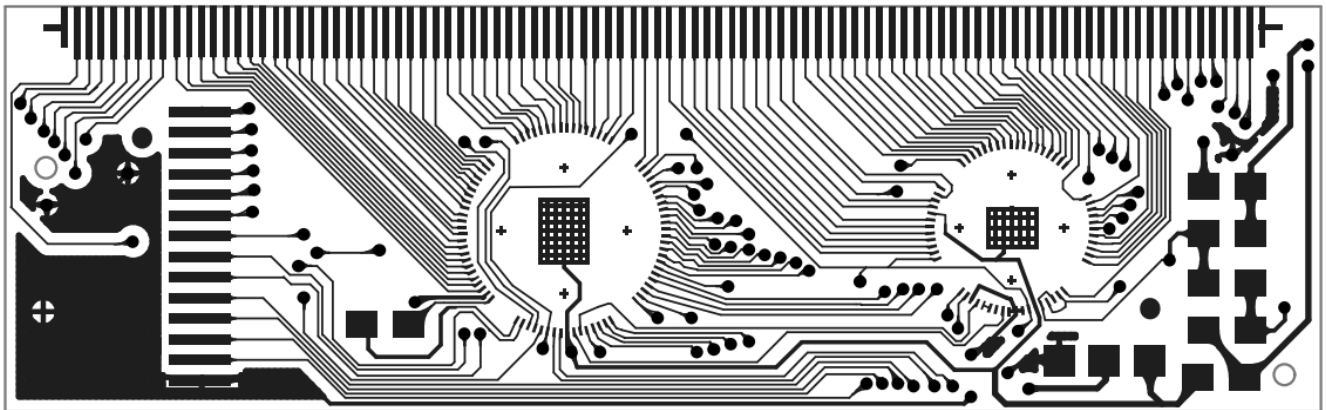

7. MAXIMUM ABSOLUTE LIMIT

Item	Symbol	Standard value	Unit
Power Supply Voltage(1)	V _{DD}	-0.3~+7.0	V
Power Supply Voltage(2)	V _{LCD}	V _{DD} -10.0~V _{DD} +0.3	V
Input Voltage	V _{IN}	-0.3~V _{DD} +0.3	V
Operating Temperature	T _{opr}	-20~+70	°C
Storage Temperature	T _{stg}	-25~+75	°C

8. ELECTRICAL CHARACTERISTICS

8-1. DC Characteristics (V_{DD}=4.5V~5.5V, T_a=-20°C to +70°C)

Item	Symbol	Standard Value			Test Condition	Unit
		MIN	TYP	MAX		
Operating Voltage	V _{DD}	4.7	5	5.3	-----	V
LCD Driving Voltage	V _{LCD}	4.2	4.5	4.8	V _{DD} -V ₀	V
Supply Current	I _{DD}	----	TBD	----	-----	mA

8-2 AC Characteristics (VDD=4.5V~5.5V, Ta= -20°C to +70°C)

8-2-1 Write Mode (Writing Data from MPU to Module Series)

Characteristic	Symbol	Min	Type	Max	Unit	Test PIN
Enable Cycle Time	t_c	1200	---	---	ns	E
Enable Pulse Time	T_{PW}	140	---	---	ns	E
Enable Rise/Fall Time	T_R, T_F	---	---	25	ns	E
Address Set-up Time	T_{AS}	0	---	---	ns	RW,RS,E
Address Hold Time	T_{AH}	10	---	---	ns	RW,RS,E
Data Set-up Time	T_{DSW}	40	---	---	ns	DB0~DB7
Data Hold Time	T_H	10	---	---	ns	DB0~DB7

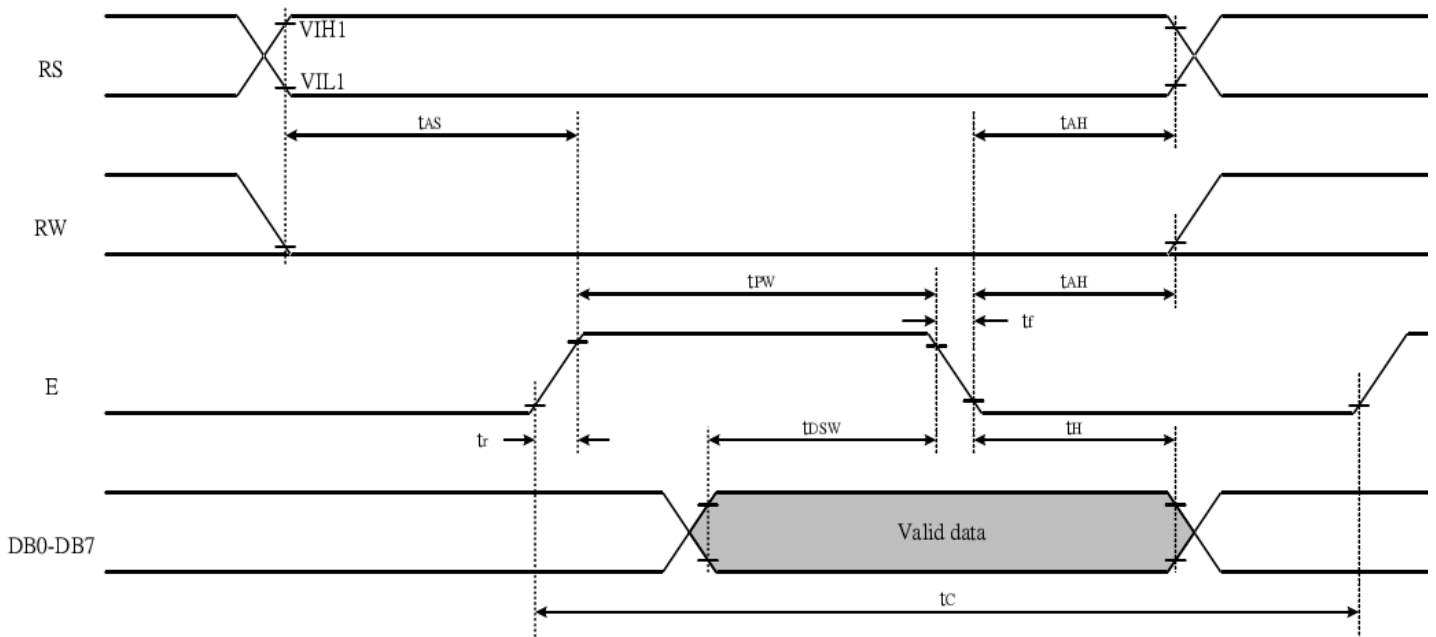

8-2-2 Read Mode (Reading Data from Module Series to MPU)

Characteristic	Symbol	Min	Type	Max	Unit	Test PIN
Enable Cycle Time	t_c	1200	---	---	ns	E
Enable Pulse Time	T_{PW}	140	---	---	ns	E
Enable Rise/Fall Time	T_R, T_F	---	---	25	ns	E
Address Set-up Time	T_{AS}	0	---	---	ns	RW,RS,E
Address Hold Time	T_{AH}	10	---	---	ns	RW,RS,E
Data Set-up Time	T_{DDR}	---	---	100	ns	DB0~DB7
Data Hold Time	T_H	10	---	---	ns	DB0~DB7

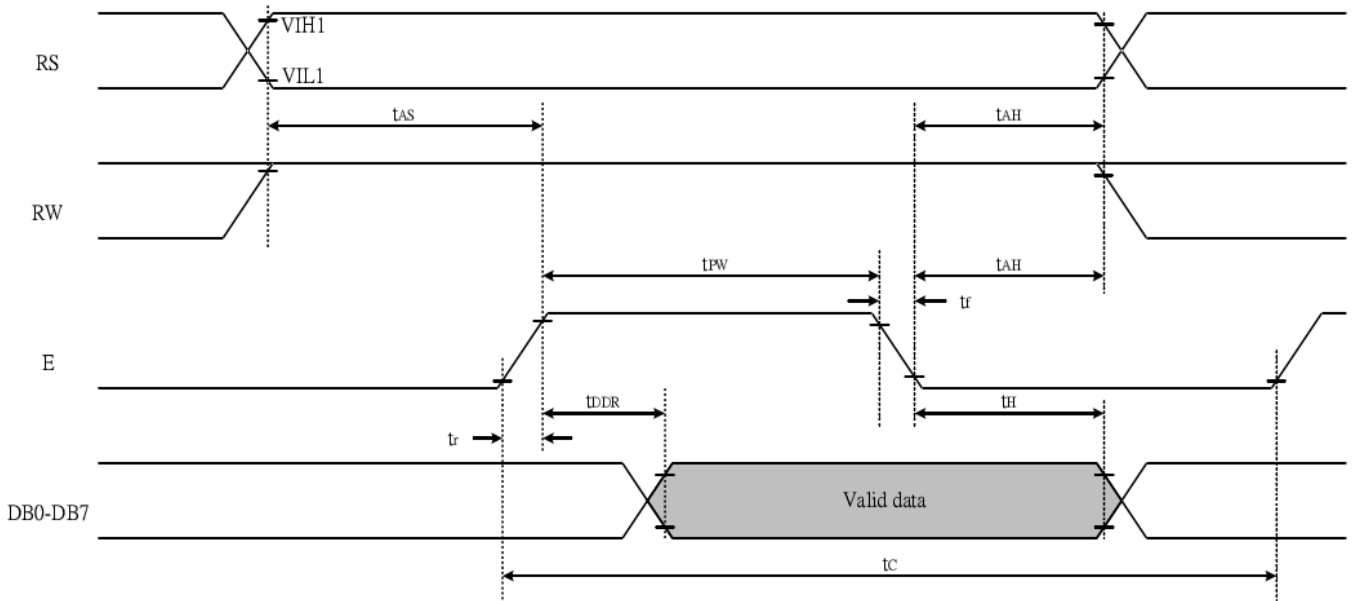

9. DISPLAY DATA RAM (DDRAM)

	1	2	3	4	5	6	7	8	9	10	11	12	13	14	15	16	← DISPLAY POSITION
FIRST LINE	00	01	02	03	04	05	06	07	08	09	0A	0B	0C	0D	0E	0F	← DDRAM ADDRESS
SECOND LINE	40	41	42	43	44	45	46	47	48	49	4A	4B	4C	4D	4E	4F	

10. INSTRUCTION TABLE

Command	RS	R/W	DB7	DB6	DB5	DB4	DB3	DB2	DB1	DB0	Execution time (fosc=270KHz)	Remark
Clear Display	0	0	0	0	0	0	0	0	0	1	1.52ms	Write"20H" to DDRAM. And set DDRAM address to "00H" from AC
Return home	0	0	0	0	0	0	0	0	1	x	1.52ms	Set DDRAM address to "00H" from AC and return cursor to its original position if shifted. The contents of DDRAM are not changed.
Entry mode Set	0	0	0	0	0	0	0	1	I/D	S	37us	Sets cursor move direction and specifies display shift. These operations are performed during data write and read.
Display on/off control	0	0	0	0	0	0	1	D	C	B	37us	D=1: entire display on C=1: cursor on B=1: cursor position on
Cursor or Display Shift	0	0	0	0	0	1	S/C	R/L	x	x	37us	Set cursor moving and display shift control bit, and the direction, without changing DDRAM data.
function Set	0	0	0	0	1	DL	N	F	x	x	37us	DL: interface data is 8/4 bits N: number of line is 2/1 F: font size is 5x11/5x8
Set CGRAM address	0	0	0	1	AC5	AC4	AC3	AC2	AC1	AC0	37us	Set CGRAM address in address counter
Set DDRAM address	0	0	1	AC6	AC5	AC4	AC3	AC2	AC1	AC0	37us	Set DDRAM address in address counter
Read busy flag& address	0	1	BF	AC6	AC5	AC4	AC3	AC2	AC1	AC0	0us	Whether during internal operation or not can be known by reading BF. The contents of address counter can also be read.
Write data to RAM	1	0	D7	D6	D5	D4	D3	D2	D1	D0	37us	Write data into internal RAM (DDRAM/CGRAM)
Read data from RAM	1	1	D7	D6	D5	D4	D3	D2	D1	D0	37us	Read data from internal RAM (DDRAM / CGRAM)

Note:

Be sure the ST7066U is not in the busy state (BF=00 before sending an instruction from the MPU to the ST7066U. If an instruction is sent without checking the busy flag, the time between the first instruction and next instruction will take much longer than the instruction time itself. Refer to instruction table for the list of each instruction execution time.

11. LCM INITIALIZING BY INSTRUCTION

- 8-bit Interface ($f_{osc}=270KHz$)

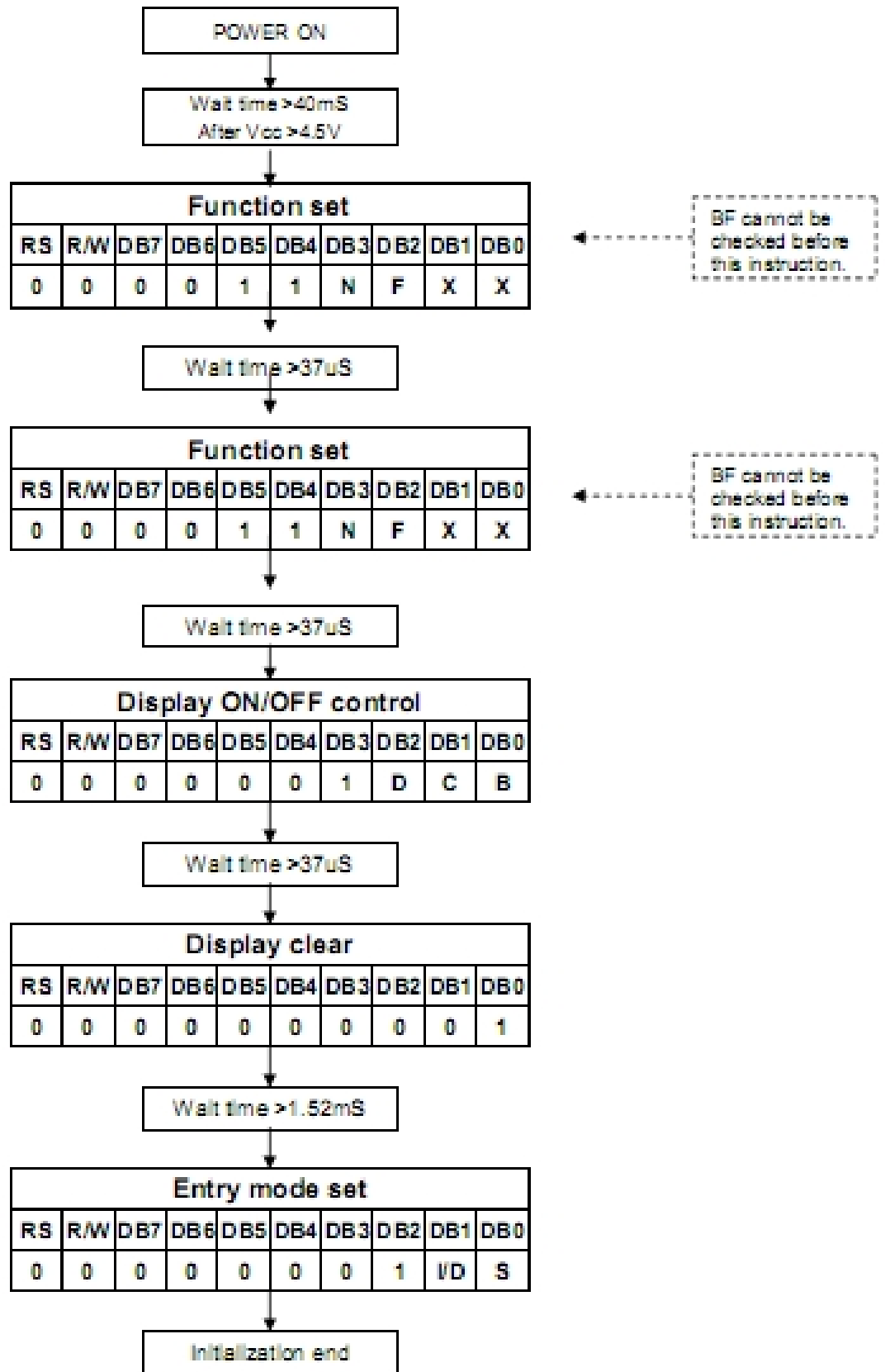

● 4-bit Interface (fosc=270KHz)

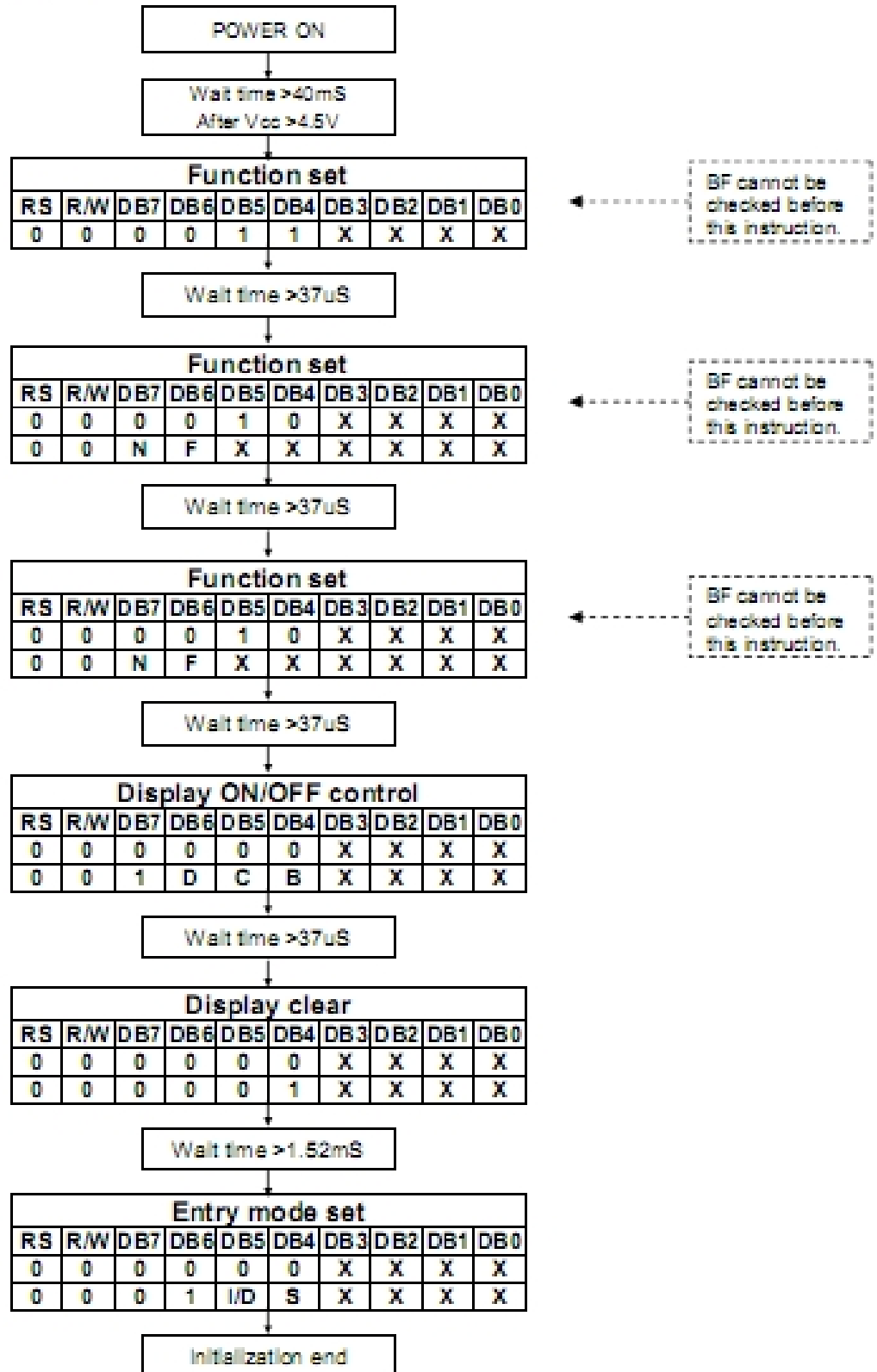

12. CHARACTER GENERATOR ROM

NO.7066-0A

b7-b4 b3-b0	0000	0001	0010	0011	0100	0101	0110	0111	1000	1001	1010	1011	1100	1101	1110	1111
0000	CG RAM (1)			0	1	P	Q	R				一	二	三	四	五
0001	(2)		!	1	A	a	q				=	F	f	G	g	h
0010	(3)		"	2	B	b	r				r	イ	ウ	×	p	q
0011	(4)		#	3	C	c	s				┘	ウ	テ	エ	o	o
0100	(5)		\$	4	D	d	t				√	エ	ト	フ	u	o
0101	(6)		%	5	E	e	u				*	オ	★	1	o	0
0110	(7)		&	6	F	f	v				ヲ	カ	ニ	ヨ	p	o
0111	(8)		'	7	G	g	w				ヲ	サ	ア	ワ	g	o
1000	(1)		(8	H	h	x				ノ	ウ	ホ	ウ	o	o
1001	(2))	9	I	i	y				ウ	ウ	ノ	ウ	u	u
1010	(3)		*	:	J	j	z				エ	コ	ノ	ノ	U	o
1011	(4)		+	;	K	k	<				オ	サ	ヒ	ロ	o	o
1100	(5)		,	<	L	l	l				オ	ウ	ウ	ウ	o	o
1101	(6)		-	=	M	m	>				ユ	ア	ノ	ウ	ト	+
1110	(7)		.	>	N	n	*				ヨ	ヒ	ホ	ノ	o	o
1111	(8)		/	?	O	o	*				ウ	ウ	ア	ノ	o	o

13. MODULE ACCEPT QUALITY LEVEL (AQL)

13.1 AQL Standard Value: Fatal Defect =0.1, Major Defect=0.65; Minor Defect =2.5.

13.2 Curtailed Inspection Scheme

Type	Batch Qty	inspection Qty	inspection rate	AQL value	pass	Reject
module product	350PCS < 1000PCS	125pcs	>25%	0.1	0	1
				0.65	2	3
				2.5	7	8
	200PCS < 350PCS	80pcs	>23%	0.1	0	1
				0.65	1	2
				2.5	5	6
	<200PCS	32pcs	>16%	0.1	0	1
				0.65	0	1
				2.5	4	5
Module sample	<200PCS	All inspected	/	/	/	The sample will be reject when the fateful defect>2pcs or main defect>5pcs.
	>200PCS	125pcs				

- Notes:**
- 1). Batch QTY is the production amount that Production department ship to QA department.
 - 2). All of product will be inspected if the batch QTY less than inspected QTY.
 - 3). Each batch fixed to be 500pcs.

14. RELIABILITY TEST

Operating life time: Longer than 50000 hours (at room temperature without direct irradiation of sunlight)

Reliability characteristics shall meet following requirements.

TEMPERATURE TESTS	NORMAL GRADE
High Temperature Storage	+75°C x 96hrs (Without Polarizer)
Low Temperature Storage	-25°C x 96hrs
High Temperature Operation	+70°C x 96hrs
Low Temperature Operation	-20°C x 96hrs
High Temperature, High Humidity	+70°C x 95%RH x 96hrs (Without Polarizer)
Thermal Shock	<div style="border: 1px solid black; padding: 5px; display: inline-block;"> -20°C x 30min. ↓ 10s 5Cycles ↓ +70°C x 30min. </div>
Vibration Test	Frequency x Swing x Time 40Hz x 4mm x 4hrs
Drop Test	Drop height x Times 1.0m x 6times

15. QUALITY DESCRIPTION

DEFECT SPECIFICATION:

Specific type-related items are covered in this sheet.

a: Table for Cosmetic defects
 (Note: nc = not counted).
 Sizes and number of defects
 (Max. Qty)

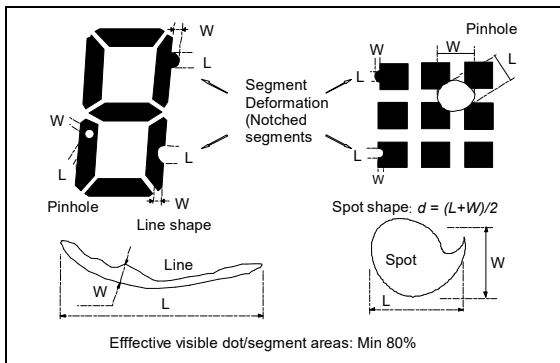

Examples/ Shapes

b: Glass defects

b1: Glass defects at contact ledge

b2: Glass chipping in other areas shall not be in conflict

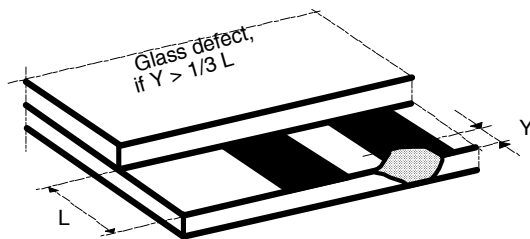

with the product's function.

Defect Type	Max. defect size [μm] d or L W	Max. Quantity.
Black or White Spots	$d \leq 150$	nc
	$150 < d \leq 300$	5
Black or White Lines	-- $W \leq 10$	nc
	$L \leq 5000$ $W \leq 30$	3
	$L \leq 2000$ $W \leq 50$	2
Pinhole	$d \leq 150$	nc
	$150 < d \leq 300$	1/segment
(Total defects)		(5)
Segment Deformation	$W \leq 100$	nc
Bubble (e.g. under pola)	$d \leq 150$	nc
	$200 < d \leq 400$	3
	$400 < d \leq 600$	1

16. LCD MODULES HANDLING PRECAUTIONS

- Please remove the protection foil of polarizer before using.
- The display panel is made of glass. Do not subject it to a mechanical shock by dropping it from a high place, etc.
- If the display panel is damaged and the liquid crystal substance inside it leaks out, do not get any in your mouth. If the substance come into contact with your skin or clothes promptly wash it off using soap and water.
- Do not apply excessive force to the display surface or the adjoining areas since this may cause the color tone to vary.
- The polarizer covering the display surface of the LCD module is soft and easily scratched. Handle this polarize carefully.
- To prevent destruction of the elements by static electricity, be careful to maintain an optimum work environment.
 - Be sure to ground the body when handling the LCD module.
 - Tools required for assembly, such as soldering irons, must be properly grounded.
 - To reduce the amount of static electricity generated, do not conduct assembly and other work under dry conditions.
 - The LCD module is coated with a film to protect the display surface. Exercise care when peeling off this protective film since static electricity may be generated.
- Storage precautions
When storing the LCD modules, avoid exposure to direct sunlight or to the light of fluorescent lamps. Keep the modules in bags designed to prevent static electricity charging under low temperature / normal humidity conditions (avoid high temperature / high humidity and low temperatures below 0°C). Whenever possible, the LCD modules should be stored in the same conditions in which they were shipped from our company.

17. OTHERS

- Liquid crystals solidify at low temperature (below the storage temperature range) leading to defective orientation of liquid crystal or the generation of air bubbles (black or white). Air bubbles may also be generated if the module is subjected to a strong shock at a low temperature.
- If the LCD modules have been operating for a long time showing the same display patterns may remain on the screen as ghost images and a slight contrast irregularity may also appear. Abnormal operating status can be resumed to be normal condition by suspending use for some time. It should be noted that this phenomena does not adversely affect performance reliability.
- To minimize the performance degradation of the LCD modules resulting from caused by static electricity, etc. exercise care to avoid holding the following sections when handling the modules:
 - Exposed area of the printed circuit board.
 - Terminal electrode sections.