

DISPLAY Elektronik GmbH

DATA SHEET

LCD MODULE

DEM 240128C2 FGH-PW

Product Specification

Version: 1

09.12.2022

CONTENTS

1. FUNCTIONS & FEATURES2

2. MECHANICAL SPECIFICATIONS.....2

3. EXTERNAL DIMENSIONS3

4. BLOCK DIAGRAM4

5. PIN ASSIGNMENT.....5

6. POWER SUPPLY.....6

7. ABSOLUTE MAXIMUM RATINGS(VSS=0V, TA=25°C)6

8. PCB DRAWING AND DESCRIPTION7

9. BACKLIGHT ELECTRICAL/OPTICAL SPECIFICATIONS.....9

10. ELECTRICAL CHARACTERISTICS10

11. COMMAND DEFINITIONS.....12

12. QUALITY DESCRIPTION14

13. MODULE ACCEPT QUALITY LEVEL (AQL)14

14. RELIABILITY TEST15

15. LCD MODULES HANDLING PRECAUTIONS.....16

16. OTHERS16

1. FUNCTIONS & FEATURES

MODULE NAME	LCD Type	Remark
DEM 240128C2 FGH-PW	FSTN Transflective Positive Mode	DC/DC Converter TJ7660 / AIP7660

- Glass Thickness : 1.1mm
- Viewing Direction : 6 O'clock
- Driving Scheme : 1/128Duty, 1/12 Bias
- Power Supply for logic : 5.0 Volt (typ.)
- Backlight Color : LED, White
- Display Content : 240 x 128 Dots
- V_{LCD} : 17.0 Volt (typ.)
- Driver IC : UCi0086 (Ultrachip)
- Controller IC : UCi6963 (Ultrachip)
- RoHS Conformed

2. MECHANICAL SPECIFICATIONS

- Module Size : 100.00 x 65.00 x 12.30 mm
- Viewing Area : 78.00 x 45.00 mm
- Active Area : 71.96 x 42.2 mm
- Dot Pitch : 0.30 x 0.33 mm
- Dot Size : 0.26 x 0.29 mm
- Dot Gap : 0.04 mm

3. EXTERNAL DIMENSIONS

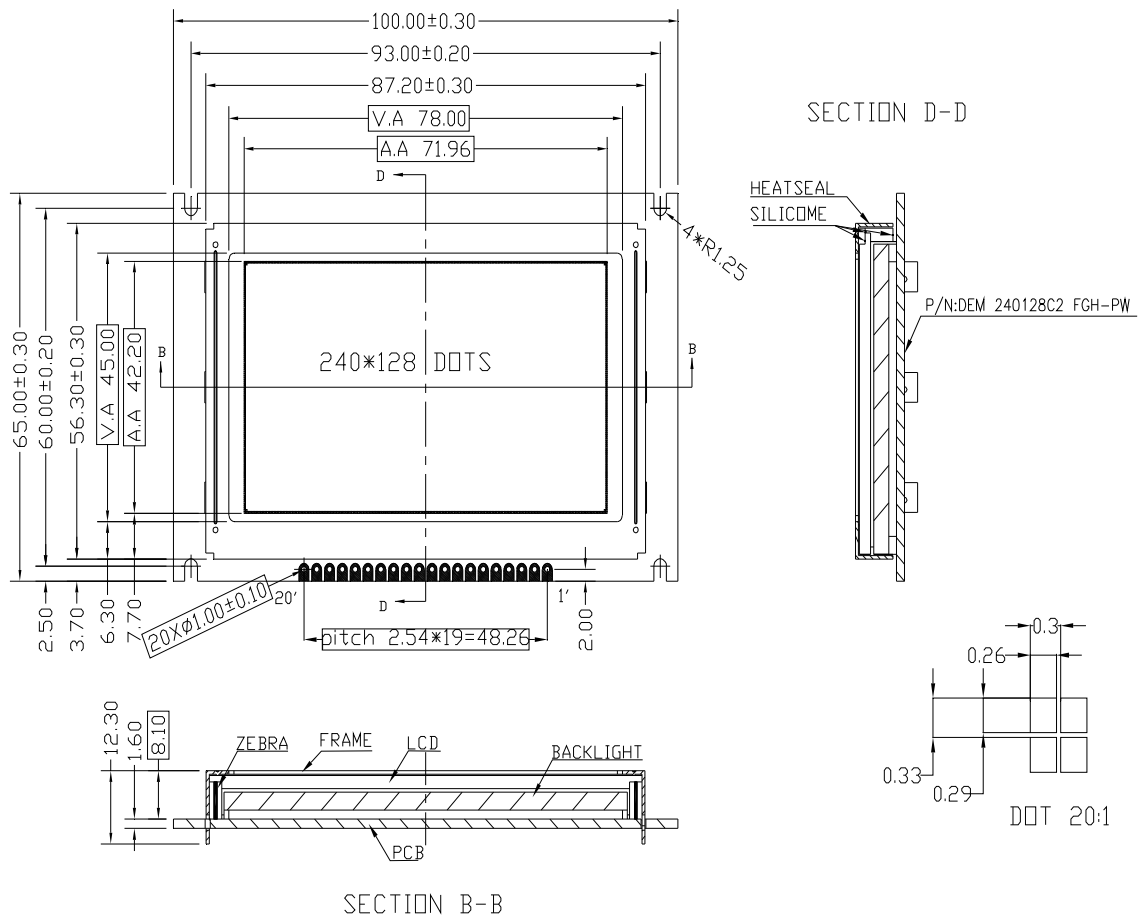

Remarks:

- 1, Unmarked Tolerance ± 0.30
- 2, All material comply with RoHs.

4. BLOCK DIAGRAM

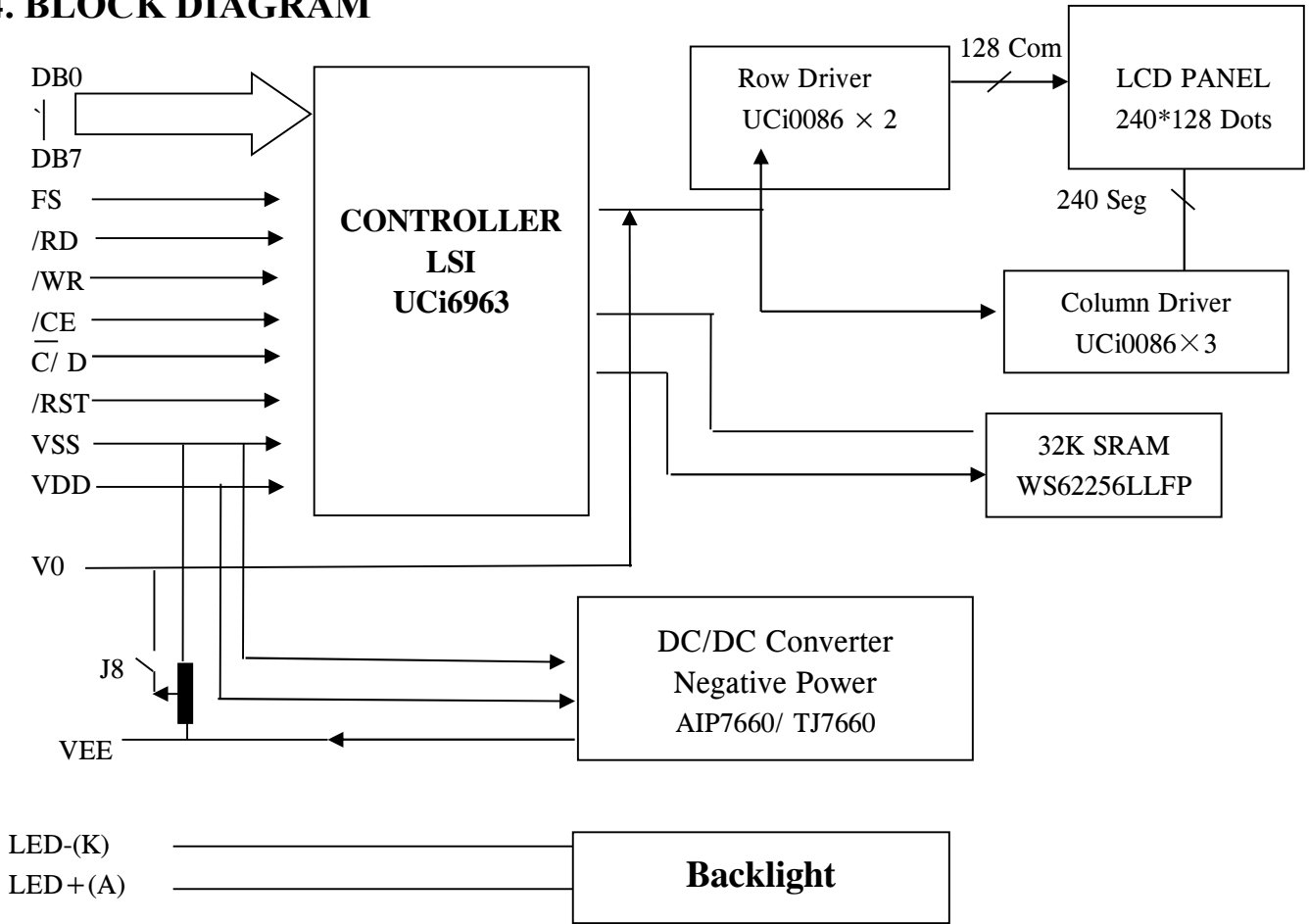

5. PIN ASSIGNMENT

NO.	SYMBOL	FUNCTION
1	VEE	Power supply output for LCD.
2	VSS	Ground (0V)
3	VDD	Power Supply(+5V)
4	V0	Power Supply for LCD Drive
5	/WR	Data write. Write data to controller UCi6963 when “L”
6	/RD	Data read. Read data from controller UCi6963 when “L”
7	/CE	Chip enable of controller when “L”
8	C/ D	Command/Data read/write. “H” for command read/write and “L” for data read/write
9	/RST	Controller reset when “L”
10	DB0	Data input/output(LSB)
11	DB1	Data input/output
12	DB2	Data input/output
13	DB3	Data input/output
14	DB4	Data input/output
15	DB5	Data input/output
16	DB6	Data input/output
17	DB7	Data input/output(MSB)
18	FS	Font select. “H” for 6x8 font & “L” for 8x8 font
19	LED+(A)	Anode of LED backlight
20	LED-(K)	Cathode of LED backlight

Note: This pin is electrically connected to the metal bezel (frame), but is otherwise not connected. User can choose to connect this pin to ground or leave it open.

6. POWER SUPPLY

Mode (Internal contrast regulation)-J8 is close

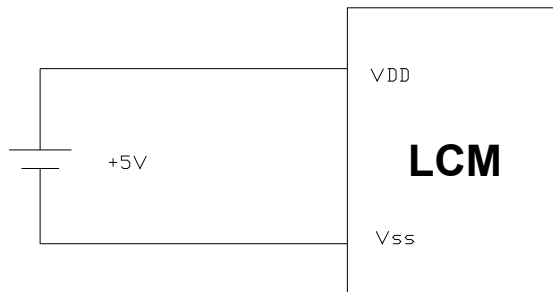

Mode (External contrast regulation)-J8 is open

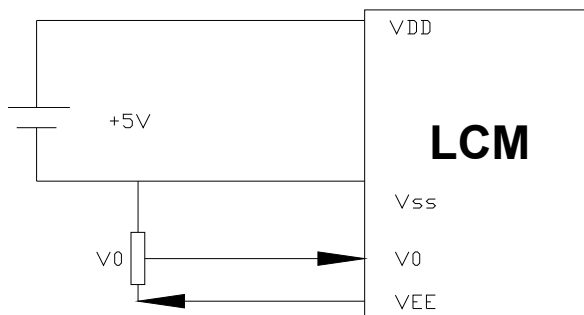

7. ABSOLUTE MAXIMUM RATINGS (V_{SS}=0V, T_a=25°C)

PARAMETER	SYMBOL	RATING	UNIT
Supply Voltage (Logic)	V _{DD}	-0.3 to 7.0	V
Input Voltage	V _{IN}	-0.3 to V _{DD} +0.3	V
Operating Temperature	T _{OPR}	-20 to 70	°C
Storage Temperature	T _{STG}	-25 to 75	°C

8. PCB DRAWING AND DESCRIPTION

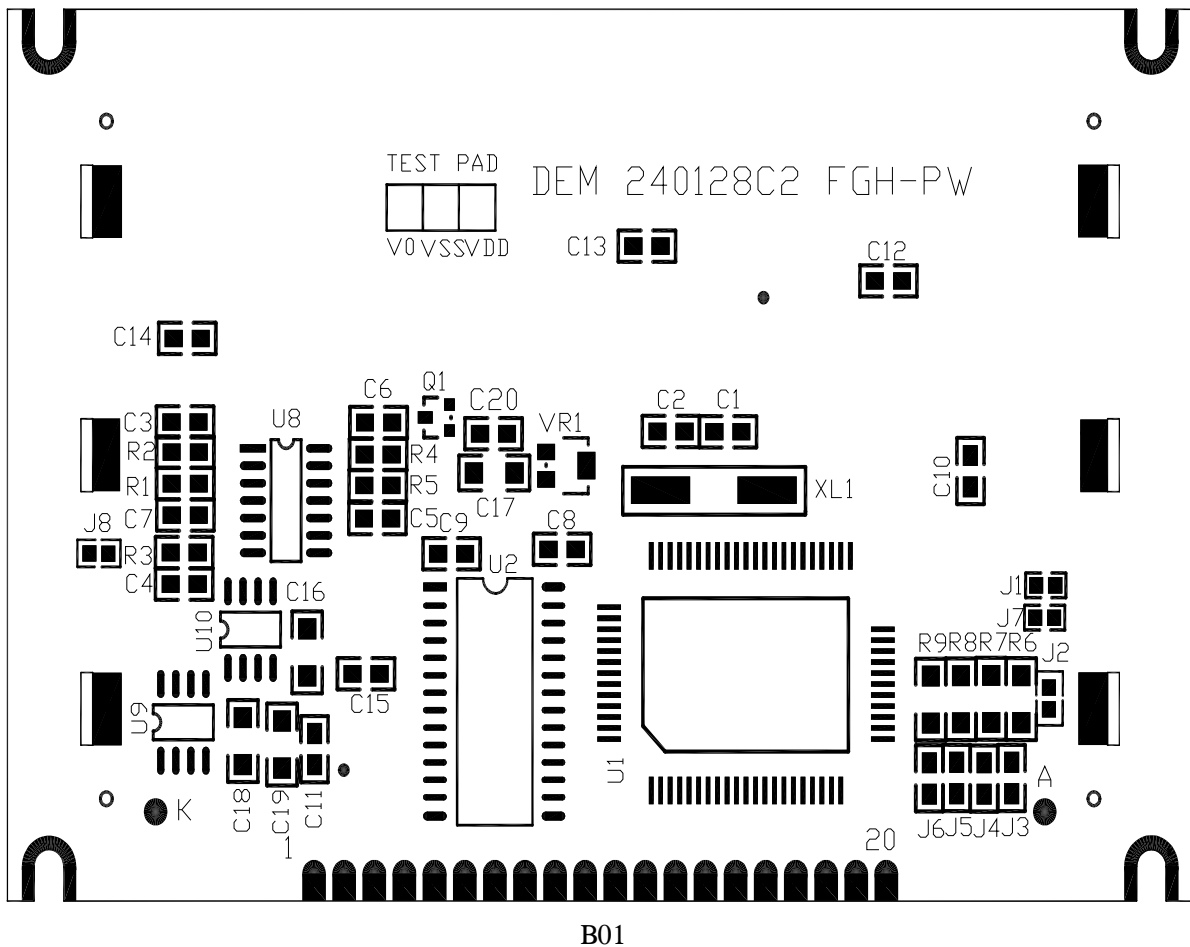

8.1 DESCRIPTION:

8-1-1. The polarity of the pin 19 and the pin 20:

J3, J5	J6, J4	LED Polarity	
		19Pin	20 Pin
Each closed	Each open	Anode	Cathode
Each open	Each closed	Cathode	Anode

Note: In application J3=J5 =0 Ohm, J4=J6=open.

8-1-2. The J1 is metal-bezel GND to module GND and J7 is mounting holes GND to module GND.

Note: In application J1=0 Ohm, J7=0 Ohm.

8-1-3. The LED resistor should be bridged when J2 is closed

Note: In application module, J2= open

8-1-4. The R6 and the R7, R8, R9 are the LED resistor.

Note: In application module, R6=10 Ohm; R7= R8= R9=open

8-1-5. The module use internal contrast regulation when J8 is closed.

Note: In application J8 is open, but potentiometer is calibrated by the factory

8.2 Example application

8-2-1. The LED resistor should be bridged as following.

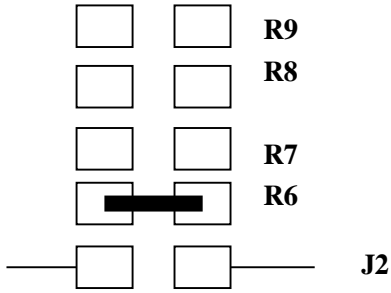

8-2-2. The 19 pin is the anode and the 20 pin is the cathode as following.

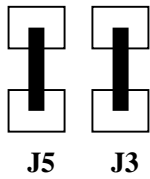

8-2-3. The 19 pin is the cathode and the 20 pin is the anode as following.

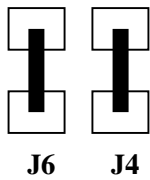

8-2-4. The metal-bezel is on ground as following.

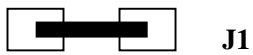

8-2-5. The mounting holes is on ground as following



8-2-6. The module use internal contrast regulation as following.

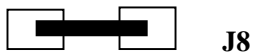

9. BACKLIGHT ELECTRICAL/OPTICAL SPECIFICATIONS

ELECTRICAL–OPTICAL CHARACTERISTICS

Item	Symbol	min.	typ.	max.	Unit	Condition
Forward Voltage	Vf	3.8	4.1	4.4	v	If= 90 mA
Reverse Current	Ir		30		μA	Vr= 0.8 V
Dominant wave length	λD				nm	If= 90 mA
Spectral Line Half width	Δλ				nm	If= 90 mA
Luminance	Lv	277	370		cd/m ²	If= 90 mA
Lifetime	50000hours (brightness reduce half)					

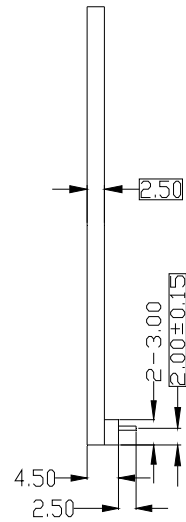
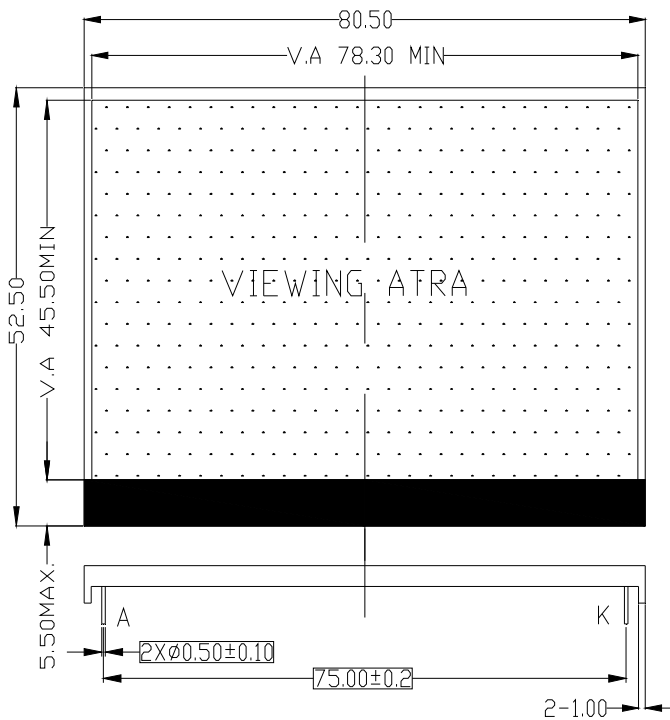

CHROMATICS COORDINATES

x	0.296	0.287	0.330	0.330
y	0.276	0.295	0.339	0.318

TOLERANCE IS ±0.01

- Remarks:
 1, Unmarked tolerance is ±0.30;
 2, Color: White
 3, All material comply with RoHs.

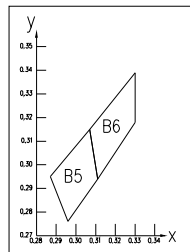
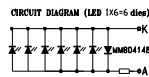

10. ELECTRICAL Characteristics

10.1 DC Characteristics

Parameter	Symbol	Conditions	Min.	Typ.	Max.	Units
Supply Voltage (Logic)	V _{DD}	-	4.7	5.0	5.3	V
High Level Input Voltage	V _{IH}	-	0.8V _{DD}	-	V _{DD}	V
Low Level Input Voltage	V _{IL}	-	0	-	0.2 V _{DD}	V
High Level Output Voltage	V _{OH}		V _{DD} -0.3	-	V _{DD}	V
Low Level Output Voltage	V _{OL}		0	-	0.3	V
Current Consumption(Operating)	I _{DD(1)}	V _{DD} =5.0V f _{OSC} = 4.0 MHz	-	3.0	5	mA
Current Consumption(Halt)	I _{DD(2)}	V _{DD} =5.0V		1	2	uA

10.2 AC Characteristics

Parameter	Symbol	Min.	Max.	Units
C/D Setup Time	t _{CDS}	100	-	ns
C/D Hold Time	t _{CDH}	10	-	ns
CE, RD, WR Pulse Width	t _{CE} , t _{RD} , t _{WR}	80	-	ns
Data Setup Time	t _{DS}	80	-	ns
Data Hold Time	t _{DH}	40	-	ns
Access Time	t _{ACC}	-	150	ns
Output Hold Time	t _{OH}	10	50	ns

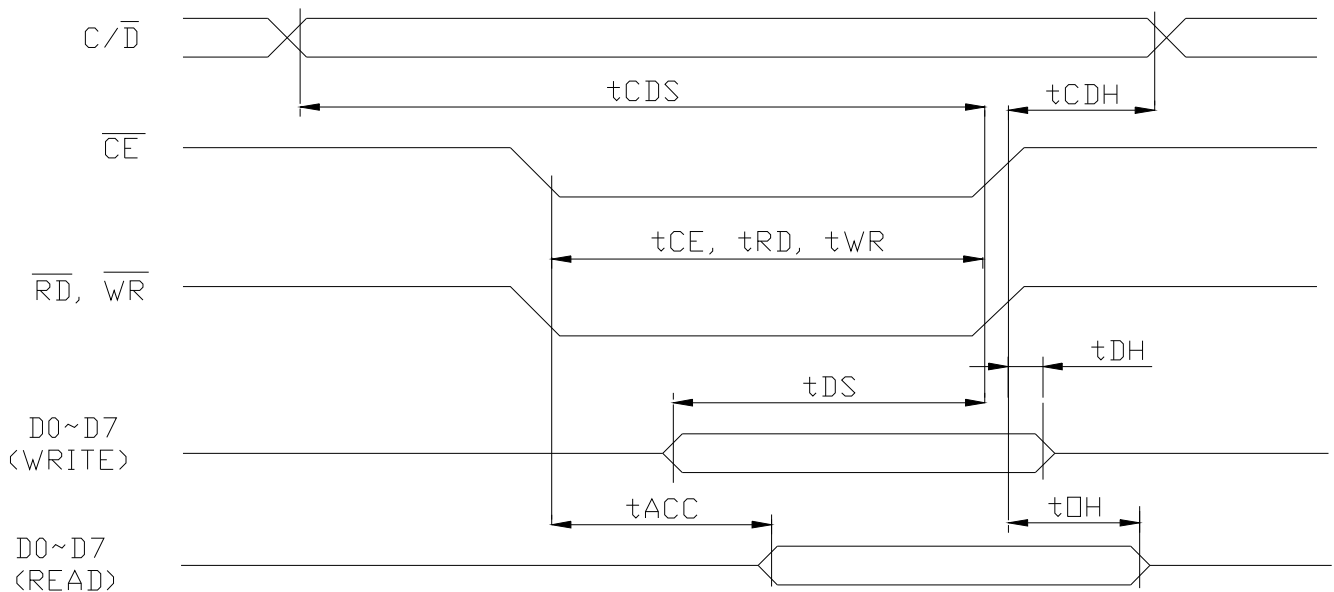

10.3 Power Supply ON/OFF/RESET Sequence

- ON Sequence

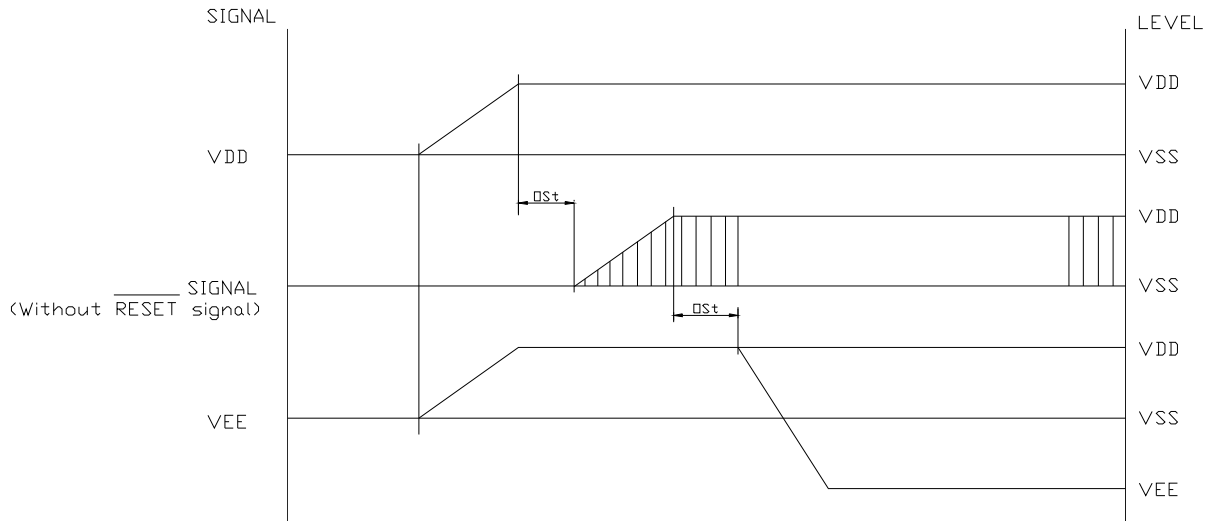

- OFF Sequence

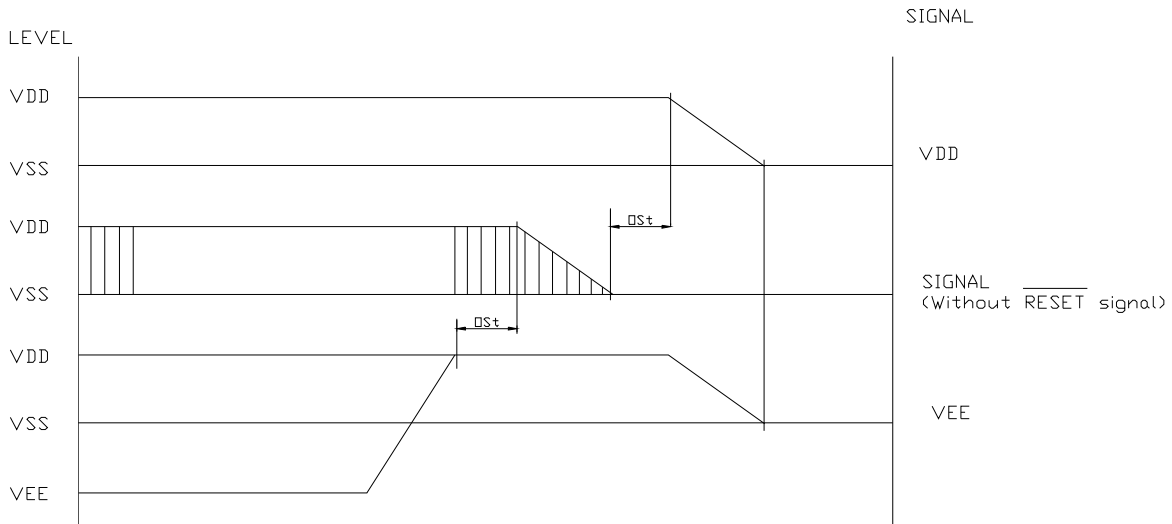

- Reset Sequence

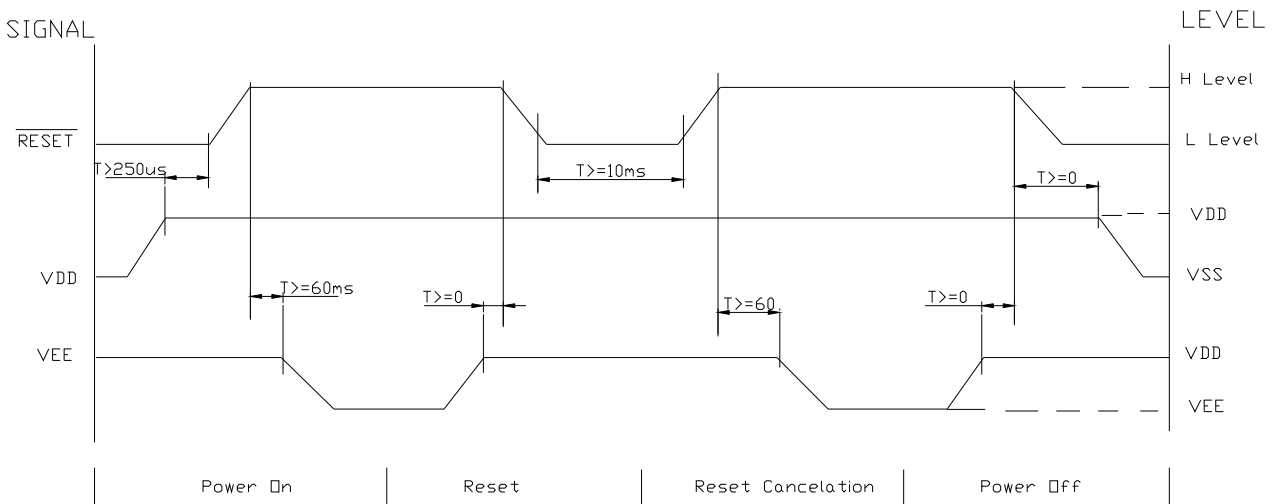

Please maintain the above sequence when turning on and off the power supply of the module.

If VEE is supplied to the module while internal alternate signal for LCD driving (M) is unstable or RESET is active, DC component will be supplied to the LCD panel. This may cause damage to the LCD module.

11. COMMAND DEFINITIONS

No.	Command	C/D	W/R	D7	D6	D5	D4	D3	D2	D1	D0	Action	Value
1.	Set Cursor Pointer	1	0	0	0	1	0	0	0	0	1		21h
		0	0	#	#	#	#	#	#	#	#	Set X address	
		0	0	#	#	#	#	#	#	#	#	Set Y address	
2.	Set Offset Register	1	0	0	0	1	0	0	0	1	0		22h
		0	0	#	#	#	#	#	#	#	#	Data	
		0	0	0	0	0	0	0	0	0	0	0	
3.	Set Address Pointer	1	0	0	0	1	0	0	1	0	0		24h
		0	0	#	#	#	#	#	#	#	#	Low address	
		0	0	#	#	#	#	#	#	#	#	High address	
4.	Set Text Home Addr.	1	0	0	1	0	0	0	0	0	0		40h
		0	0	#	#	#	#	#	#	#	#	Low address	
		0	0	#	#	#	#	#	#	#	#	High address	
5.	Set Text Area	1	0	0	1	0	0	0	0	0	1		41h
		0	0	#	#	#	#	#	#	#	#	Columns	
		0	0	0	0	0	0	0	0	0	0	0	
6.	Set Graphic Home Addr.	1	0	0	1	0	0	0	0	1	0		42h
		0	0	#	#	#	#	#	#	#	#	Low address	
		0	0	#	#	#	#	#	#	#	#	High address	
7.	Set Graphic Area	1	0	0	1	0	0	0	0	1	1		43h
		0	0	#	#	#	#	#	#	#	#	Columns	
		0	0	0	0	0	0	0	0	0	0	0	
8.	OR mode	1	0	1	0	0	0	-	0	0	0		8xh
9.	EXOR mode	1	0	1	0	0	0	-	0	0	1		
10.	AND mode	1	0	1	0	0	0	-	0	1	1		
11.	Text Attribute mode	1	0	1	0	0	0	-	1	0	0		
		0	0	-	-	-	-	#	#	#	#		
12.	Internal CG ROM mode	1	0	1	0	0	0	0	-	-	-		
13.	External CG RAM mode	1	0	1	0	0	0	1	-	-	-		
14.	Display Mode	1	0	1	0	0	1	#	#	#	#	Switch Graphic/Text/Cursor/Blink ON/OFF	9xh
15.	Cursor Pattern Select	1	0	1	0	1	0	0	#	#	#	Set cursor: 1~8-line	Axh
16.	Data-write and Increase ADP	1	0	1	1	0	0	0	0	0	0		C0h
		0	0	#	#	#	#	#	#	#	#	Data	
17.	Data-read and Increase ADP	1	1	1	1	0	0	0	0	0	1		C1h
18.	Data-write and Decrease ADP	1	0	1	1	0	0	0	0	1	0		C2h
		0	0	#	#	#	#	#	#	#	#	Data	
19.	Data-read and Decrease ADP	1	1	1	1	0	0	0	0	1	1		C3h
20.	Data-write and Non-variable ADP	1	0	1	1	0	0	0	1	0	0		C4h
		0	0	#	#	#	#	#	#	#	#	Data	
21.	Data-read and Non-variable ADP	1	1	1	1	0	0	0	1	0	1		C5h
22.	Set Data Auto Write	1	0	1	0	1	1	0	0	0	0		B0h
23.	Set Data Auto Read	1	0	1	0	1	1	0	0	0	1		B1h
24.	Auto Reset	1	0	1	0	1	1	0	0	1	0		B2h
25.	Screen Peek	1	0	1	1	1	0	0	0	0	0		E0h
26.	Screen Copy	1	0	1	1	1	0	1	0	0	0		E8h
27.	Bit Set/Reset	1	0	1	1	1	1	#	#	#	#	Set/Reset Bit 0~7	Fxh
28.	Whole Screen Reverse (Triple-byte command)	1	0	1	1	0	1	0	0	0	0		D0h
		0	0	-	-	-	-	-	-	-	#	0: Normal 1: Reverse	
		0	0	-	-	-	-	-	-	-	-	(Don't Care)	

No.	Command	C/D	W/R	D7	D6	D5	D4	D3	D2	D1	D0	Action	Value
29.	Blink Time (Triple-byte command)	1	0	0	1	0	1	0	0	0	0		50h
		0	0	-	-	-	-	-	#	#	#	000b: 0.066s 100b: 1s 001b: 0.25s 101b: 1.25s 010b: 0.5s 110b: 1.5s 011b: 1.75s 111b: 2s	010b
		0	0	-	-	-	-	-	-	-	-	-	(Don't Care)
30.	Cursor Auto Moving (Triple-byte command)	1	0	0	1	1	0	0	0	0	0		60h
		0	0	-	-	-	-	-	-	-	#	0: disable 1: enable	
		0	0	-	-	-	-	-	-	-	-	-	(Don't Care)
31.	CGROM Font Select (Triple-byte command)	1	0	0	1	1	1	0	0	0	0		70h
		0	0	-	-	-	-	-	-	#	#	00b: Don't care 01b: Don't care 10b: CGROM Font-01 11b: CGROM Font-02	
		0	0	-	-	-	-	-	-	-	-	-	(Don't Care)

12. QUALITY DESCRIPTION

DEFECT SPECIFICATION:

Specific type-related items are covered in this sheet.

a: Table for Cosmetic defects
 (Note: nc = not counted).
 Sizes and number of defects
 (Max. Qty)

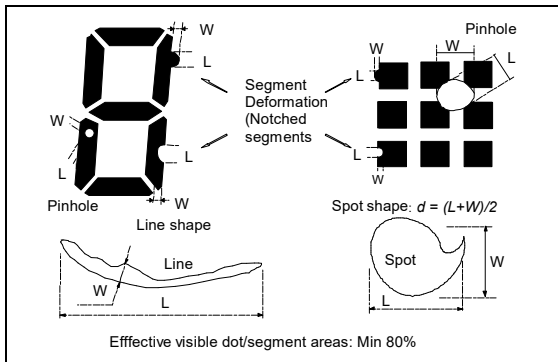

Shapes

b: Glass defects
 b1: Glass defects at contact ledge

Examples/

Defect Type	Max. defect size [μm] d or L W	Max. Quantity
Black or White Spots	$d \leq 150$	nc
	$150 < d \leq 300$	5
Black or White Lines	-- $W \leq 10$	nc
	$L \leq 5000$ $W \leq 30$	3
	$L \leq 2000$ $W \leq 50$	2
Pinhole	$d \leq 150$	nc
	$150 < d \leq 300$	1/segment
(Total defects)		(5)
Segment Deformation	$W \leq 100$	nc
Bubble (e.g. under pola)	$d \leq 150$	nc
	$200 < d \leq 400$	3
	$400 < d \leq 600$	1

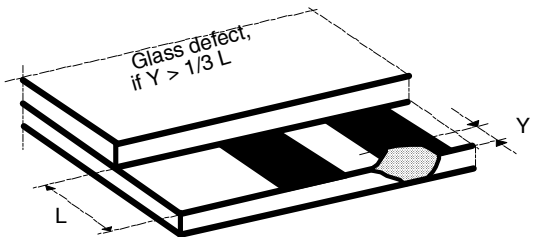

b2: Glass chipping in other areas shall not be in conflict with the product's function.

13. MODULE ACCEPT QUALITY LEVEL (AQL)

13.1 AQL Standard Value: Critical Defect =0.1, Major Defect=0.65; Minor Defect =2.5.

13.2 Inspection Plan: MIL-STD-105E, Normal Inspection Level II, Single Sampling Plan

14. RELIABILITY TEST

Operating life time: 50000 hours (at room temperature without direct irradiation of sunlight)

Reliability characteristics shall meet following requirements.

Test Item	Test Condition
High Temperature Storage	+75□ x 96hrs
Low Temperature Storage	-25□ x 96hrs
High Temperature Operation	+70□ x 96hrs
Low Temperature Operation	-20□ x 96hrs
High Temperature, High Humidity	+60□ x 95%RH x 96hrs
Thermal Shock	-20°C x 30min → +25°C x 10s → +70°C x 30min 5Cycles
Vibration Test	Frequency x Swing x Time 40Hz x 4mm x 4hrs
Drop Test	Drop height x No. of drops 1.0m x 6drops

15. LCD MODULES HANDLING PRECAUTIONS

- Please remove the protection foil of polarizer before using.
- The display panel is made of glass. Do not subject it to a mechanical shock by dropping it from a high place, etc.
- If the display panel is damaged and the liquid crystal substance inside it leaks out, do not get any in your mouth. If the substance come into contact with your skin or clothes promptly wash it off using soap and water.
- Do not apply excessive force to the display surface or the adjoining areas since this may cause the color tone to vary.
- The polarizer covering the display surface of the LCD module is soft and easily scratched. Handle this polarize carefully.
- To prevent destruction of the elements by static electricity, be careful to maintain an optimum work environment.
 - Be sure to ground the body when handling the LCD module.
 - Tools required for assembly, such as soldering irons, must be properly grounded.
 - To reduce the amount of static electricity generated, do not conduct assembly and other work under dry conditions.
 - The LCD module is coated with a film to protect the display surface. Exercise care when peeling off this protective film since static electricity may be generated.
- Storage precautions
When storing the LCD modules, avoid exposure to direct sunlight or to the light of fluorescent lamps. Keep the modules in bags designed to prevent static electricity charging under low temperature / normal humidity conditions (avoid high temperature / high humidity and low temperatures below 0°C). Whenever possible, the LCD modules should be stored in the same conditions in which they were shipped from our company.

16. OTHERS

- Liquid crystals solidify at low temperature (below the storage temperature range) leading to defective orientation of liquid crystal or the generation of air bubbles (black or white). Air bubbles may also be generated if the module is subjected to a strong shock at a low temperature.
- If the LCD modules have been operating for a long time showing the same display patterns may remain on the screen as ghost images and a slight contrast irregularity may also appear. Abnormal operating status can be resumed to be normal condition by suspending use for some time. It should be noted that this phenomena does not adversely affect performance reliability.
- To minimize the performance degradation of the LCD modules resulting from caused by static electricity, etc. exercise care to avoid holding the following sections when handling the modules:
 - Exposed area of the printed circuit board
 - Terminal electrode sections