

Ambient Light Sensor - Surface Mount ALS-DPDIC17-78C/L653/TR8

Features

- Good low light sensitivity
- Excellent infrared immunity
- Good output linearity across light intensity
- Automatically rejects 50/60-Hz lighting ripple
- Spectral response close to the human eye's response
- Precisely measures illumination in diverse lighting conditions
- Programmable interrupt function with user-defined upper and lower threshold settings
- 16bits digital output with I²C (standard-mode and fast-mode, up to 400 KHz)
- Excellent temperature compensation: -40 to 85°C
- Size : 2.0mm(L)*2.0mm(W)*0.63mm(H)
- The product itself will remain within RoHS compliant version
- Compliance with EU REACH
- Compliance Halogen Free(Br < 900ppm, Cl < 900ppm, Br+Cl < 1500ppm)

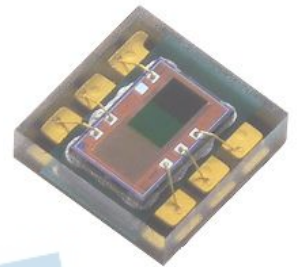

Description

The ALS-DPDIC17-78C/L653/TR8 is a light-to-digital converter that transforms light intensity to a digital signal output capable of I²C interface. It is an advanced ambient light sensor with excellent temperature compensation designed by CMOS process. Each device combines one broadband photodiode (visible plus infrared), one infrared-responding photodiode, amplifiers, and digital circuits in a single chip. Two integrating ADCs convert the photodiode currents to a digital output that represents the irradiance measured on each channel with 16-bits resolution. This digital output can be connect to a micro-controller where illumination (ambient light level) in lux is derived using an empirical formula to approximate the human eye response. The ALS-DPDIC17-78C/L653/TR8 device supports several interrupt features that can be used in many different applications.

Applications

Vehicle, Security, Camcorder, TFT LCD, Note Book, PDA, Mobile Phone, Smart Phone.

Pad Descriptions

Symbol	Type	Function
VDD	Power	Supply voltage.
ADDR	Input	I2C device address select, IO traps.
VSS	Power	Power supply ground.
SCL	Input	I2C serial clock input terminal, clock signal for I2C serial data.
INT	Output	Level or pulse interrupt.
SDA	Input / Output	I2C serial data I/O terminal, serial data I/O for I2C.

Function Block Diagram

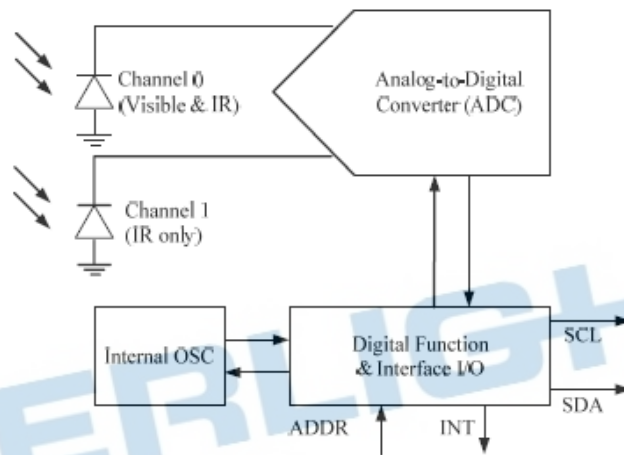

Detailed Description

ALS-DPDIC17-78C/L653/TR8 is an ambient light sensor device that contains two integrating analog-to-digital converters (ADC) that integrate currents from two photodiodes. Photodiode 0 is sensitive to both visible and infrared, while photodiode 1 is mostly sensitive to infrared light. The spectral response of the two photodiodes is independent from one another and integration of both channels occurs simultaneously. Upon completion of the conversion cycle, the conversion result is transferred to the channel 0 and channel 1 data registers, respectively. After the transfer, the device automatically begins the next integration cycle.

Communication to the device is accomplished through a standard I2C serial bus. Consequently, the ALS-DPDIC17-78C/L653/TR8 device can be easily connected to a microcontroller or embedded controller, no external circuitry is required. Please refer to the chapter "I2C Protocols" for detailed communication method. The ALS-DPDIC17-78C/L653/TR8 devices also support several interrupt features that simplifies and improves system efficiency by eliminating the need to poll a sensor for a light intensity value. The primary purpose of the interrupt function is to detect a meaningful change in light intensity or time as user wish. The ALS-DPDIC17-78C/L653/TR8 devices have the ability to define two thresholds: high and low levels. An interrupt is generated when the value of a conversion exceed either of these limits.

Absolute Maximum Ratings

Parameter	Symbol	Limit Values		Units	Notes
		Min.	Max.		
Voltages					
Supply Voltage	V_{DD}	-0.5	3.8	V	
Digital Output Voltage Range	V_O	-0.5	3.8	V	
Temperatures					
Storage Temperature	T_{stg}	-40	85	°C	
ESD					
ESD Tolerance		-	2	kV	Human body model
Note: Stresses beyond those listed under “absolute maximum ratings” may cause permanent damage to the device. These are stress ratings only and functional operation of the device at these or any other conditions beyond those indicated under “recommended operating conditions” is not implied. Exposure to absolute-maximum-ratings conditions for extended periods may affect device reliability.					

Recommended Operating Conditions

Parameter	Symbol	Min.	Typ.	Max.	Units	Notes
Supply Voltage	V_{DD}	2.7	3.3	3.6	V	
Operating Free-air Temperature	T_A	-40	-	85	°C	
SCL, SDA Input Low Voltage	V_{IL}	-	-	0.8	V	
SCL, SDA Input High Voltage	V_{IH}	2.1	-	-	V	
SDA Output Low Voltage	V_{OL}	0	-	0.3	V	$I_{OL} = 3mA$

Operating Characteristics and Electrical Characteristics (VDD = 3.3V, Ta = 25°C)

Parameter	Test Conditions	Channel	Min.	Typ.	Max.	Units
ALS detection resolution	ALS gain=X15; TIG=255T	-	-	0.006	-	lux/count
ALS maximum detection	ALS gain=X1; TIG=1T	-	-	992,656	-	lux
Dark A/DC Count Value	$E_v=0$ lux, white LED	CH0-CH1	-	-	3	count
A/DC Count Value	ALS gain=X15; TIG=19T(51.3ms); $E_v = 100$ lux, white LED		1088	1360	1632	count
	ALS gain=X15; TIG=255T(688.5ms) ; $E_v = 100$ lux , white LED	14592	18240	21888		
Supply Current	Normal	-	-	200	-	uA
	Power-down	-	-	5	-	uA
Peak Sensitivity Wavelength	-	-	-	500	-	nm

AC Electrical Characteristics (VDD = 3.3V, T_A = 25°C)

Parameter	I2C Standard Mode		I2C Fast Mode		Units
	Min.	Max.	Min.	Max.	
f _(SCL)	0	100	0	400	kHz
t _(BUF)	4.7	-	1.3	-	us
t _(HDSTA)	4	-	0.6	-	us
t _(SUSTA)	4.7	-	0.6	-	us
t _(SUSTO)	4	-	0.6	-	us
t _(HDDAT)	0	3.45	0	0.9	us
t _(SUDAT)	250	-	100	-	us
t _(LOW)	4.7	-	1.3	-	us
t _(HIGH)	4	-	0.6	-	us
t _(f)	-	300	-	300	us
t _(r)	-	1000	-	300	us

Parameter Measurement Information

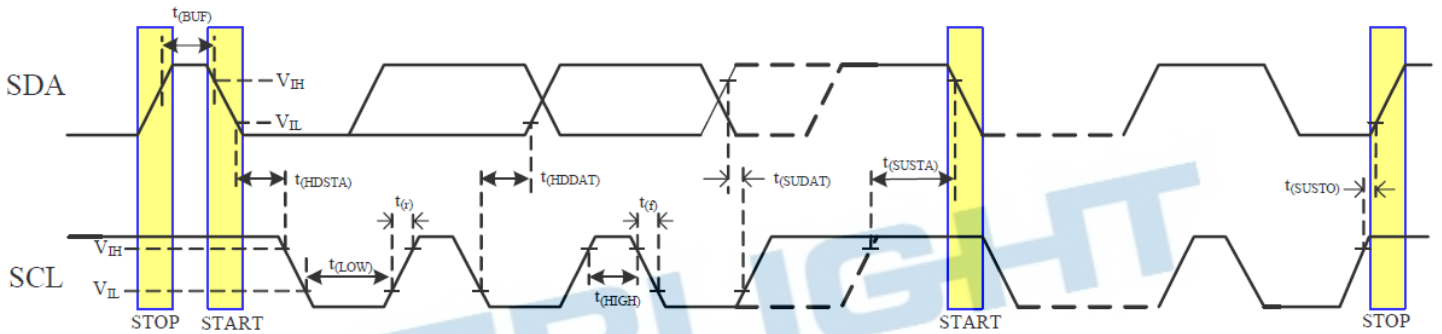

Application Circuit

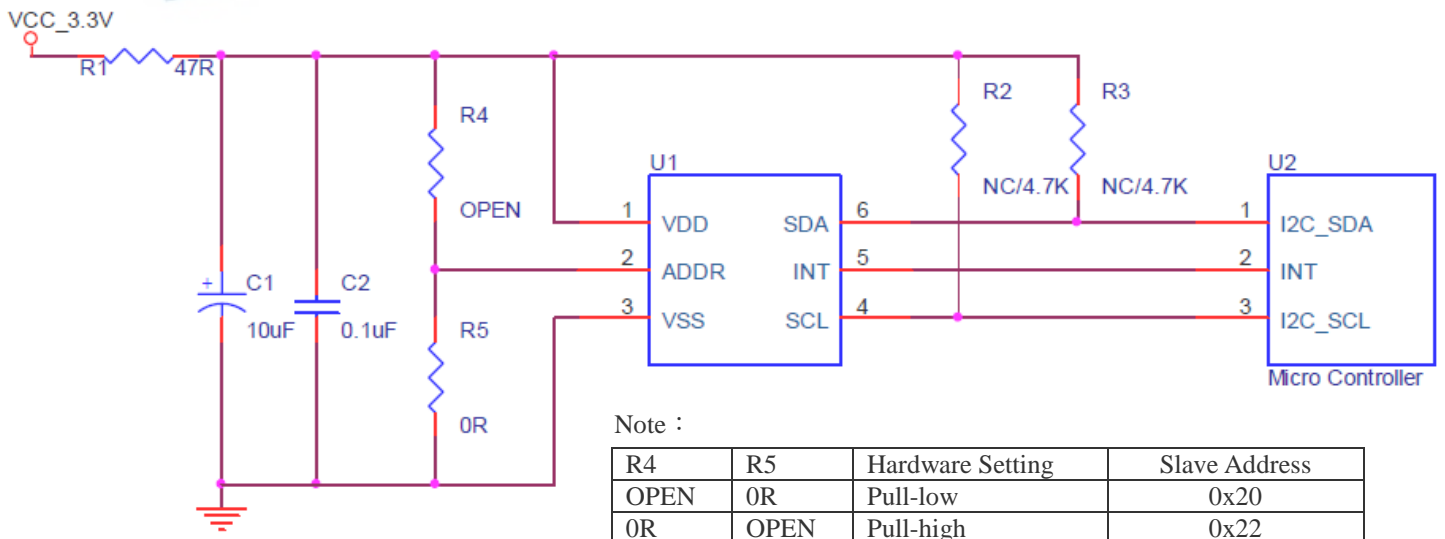

The capacitor C1 and C2 near VDD is essential for power noise rejection. The recommended value of C1 is 10uF.

Electrical and Optical Characteristics ($T_a=25^\circ\text{C}$)

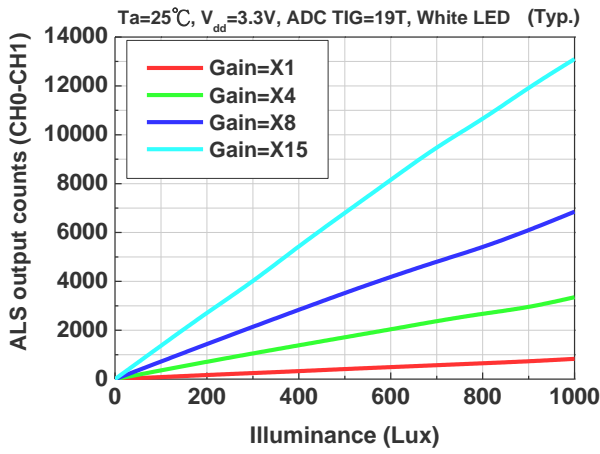

Fig.1 ALS output data vs. ALS Gain

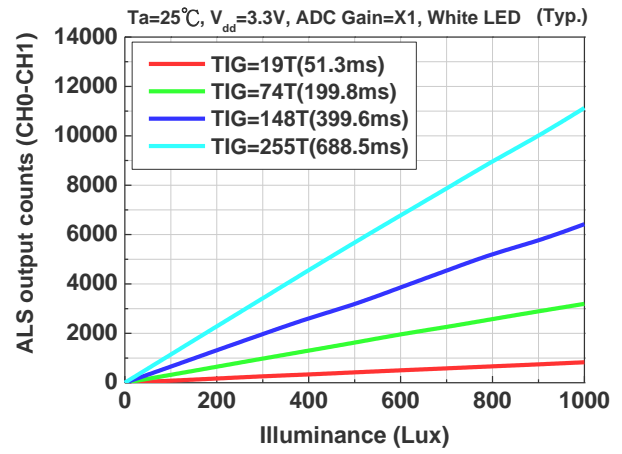

Fig.2 ALS output data vs. ADC TIG

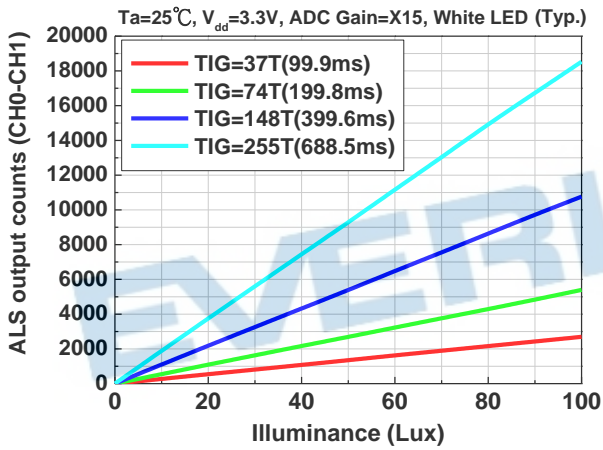

Fig.3 ALS output data vs. ADC TIG

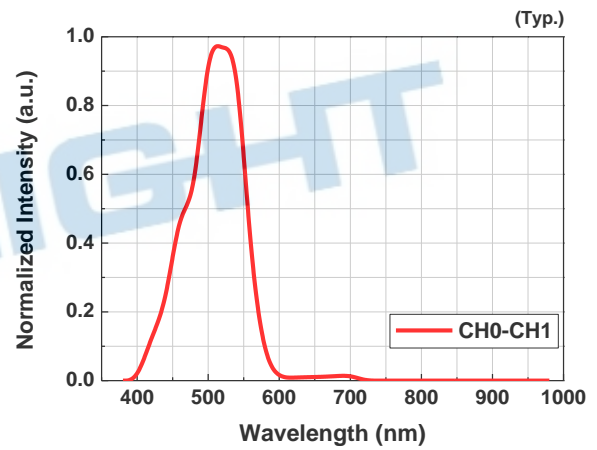
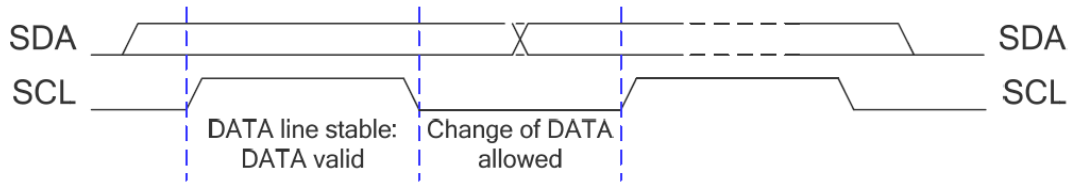

Fig.4 Spectral vs. Wavelength

NOTE: The A/DC TIG value is integration time. There are TIG=1T=2.7 ms, 19T=51.3 ms, 37T=99.9 ms, 74T=199.8 ms, 148T=399.6 ms, 255T= 688.5 ms.

I²C Bus Overview

The data on the SDA line must be stable during the HIGH period of the clock. The HIGH or LOW state of the data line can only change when the clock signal on the SCL line is LOW.



To address a specific device, the master initiates a START condition by pulling the data signal line (SDA) from a HIGH to a LOW logic level while SCL is HIGH. All slaves on the bus shift in the slave address byte on the rising edge of SCL, with the last bit indicating whether a read or write operation is intended. During the ninth clock pulse, the slave being addressed responds to the master by generating an Acknowledge and pulling SDA LOW.

Data transfer is then initiated and eight bits of data are sent, followed by an Acknowledge bit. During data transfer, SDA must remain stable while SCL is HIGH. Any change in SDA while SCL is HIGH is interpreted as a START or STOP condition.

Once all data have been transferred, the master generates a STOP condition, indicated by pulling SDA from LOW to HIGH while SCL is HIGH.

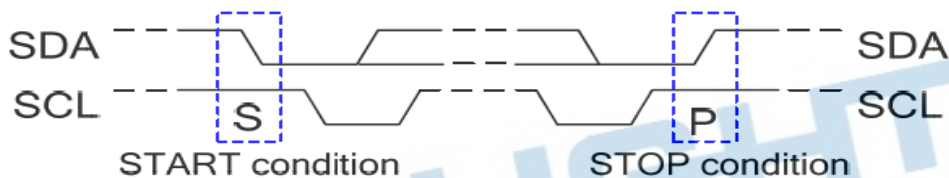

The device that initiates the transfer is called a master, and the devices controlled by the master are slaves. The bus must be controlled by a master device that generates the serial clock (SCL), controls the bus access, and generates START and STOP conditions.

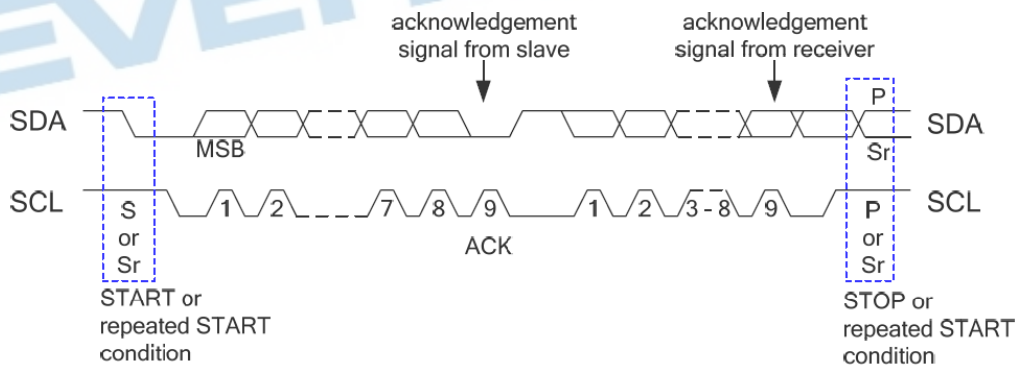

I²C Bus Address

Interface and control of the ALS-DPDIC17-78C/L653/TR8 is accomplished through a two-wire serial interface to a set of registers that provide access to device control functions and output data. The serial interface is compatible with I²C bus Fast-Mode. To communicate with the ALS-DPDIC17-78C/L653/TR8, the master must first address slave devices via a slave address byte. The slave address byte consists of seven address bits, and a direction bit indicating the intent of executing a read or write operation. The ALS-DPDIC17-78C/L653/TR8 offers two slave addresses that are selectable via an external pin (ADDR). The slave address options are shown in below.

ADDR Terminal Level	Slave Address
VSS	0010000
VDD	0010001

NOTE: The slave addresses are 7 bits. A read/write bit should be appended to the slave address by the master device to properly communicate with the ALS-DPDIC17-78C/L653/TR8 device.

I²C Bus Protocols

The ALS-DPDIC17-78C/L653/TR8 implements the following protocols of the I²C specification:

- ◆ Write Byte Protocol
- ◆ Read Byte Protocol
- ◆ Write Burst Protocol
- ◆ Read Burst Protocol

Write Byte Protocol

S	Slave Address	Wr	A	Register Address=N	A	Data N	A	P
---	---------------	----	---	--------------------	---	--------	---	---

Read Byte Protocol

S	Slave Address	Wr	A	Register Address=N	A
---	---------------	----	---	--------------------	---

S	Slave Address	Rd	A	Data N	A	P
---	---------------	----	---	--------	---	---

Write Burst Protocol

S	Slave Address	Wr	A	Register Address=N	A	Data N	A
---	---------------	----	---	--------------------	---	--------	---

Data N+1	A	Data N+2	A	P
----------	---	----------	---	-------	---

Read Burst Protocol

S	Slave Address	Wr	A	Register Address=N	A
---	---------------	----	---	--------------------	---

S	Slave Address	Rd	A	Data N	A	Data N+1	A
---	---------------	----	---	--------	---	----------	---

Data N+2	A	Data N+3	A	P
----------	---	----------	---	-------	---

Note:

A Acknowledge (this bit position may be 0 for an ACK or 1 for a NACK)

P Stop Condition

Rd Read (bit value of 1)

S Start Condition

Sr Repeated Start Condition

Wr Write (bit value of 0)

... Continuation of protocol

Master-to-Slave

Slave-to-Master

Register Table

The ALS-DPDIC17-78C/L653/TR8 is controlled and used via below registers.

Addr.	Bits	Type	Default	Name	Register Function																
0x00	[7:0]	RO	0x26	PNO_LB	Product number, Low Byte																
0x01	[7:0]	RO	0x11	PNO_HB	Product number, High Byte																
0x02	-	-	-	-	Reserved																
0x03	[7:0]	RW	0x04	OP_MODE	Operation mode																
	[7:4]	RW	0	-	Reserved. The field is always 0.																
	[3]	RW	0	-	Must set to 0																
	[2]	RW	1	-	Must set to 1																
	[1]	RW	0	PD	Power down control 0: chip active 1: chip power down																
	[0]	RW	0	-	Must set to 0																
0x04	[7:0]	RW	0x94	TIG_SEL	Integration time (TIG) is selected by TIG_SEL . The standard value with default setting is as following. <table border="1" style="margin-left: 20px;"> <thead> <tr> <th>Integration time (TIG)</th> <th>TIG_SEL Value</th> </tr> </thead> <tbody> <tr> <td>1T = 2.7ms (Typical)</td> <td>0x01</td> </tr> <tr> <td>2T = 5.4ms (Typical)</td> <td>0x02</td> </tr> <tr> <td>19T = 51.3ms (Typical)</td> <td>0x13</td> </tr> <tr> <td>37T = 99.9ms (Typical)</td> <td>0x25</td> </tr> <tr> <td>74T = 199.8ms (Typical)</td> <td>0x4A</td> </tr> <tr> <td>148T = 399.6ms (Typical)</td> <td>0x94</td> </tr> <tr> <td>255T = 688.5ms (Typical)</td> <td>0xFF</td> </tr> </tbody> </table>	Integration time (TIG)	TIG_SEL Value	1T = 2.7ms (Typical)	0x01	2T = 5.4ms (Typical)	0x02	19T = 51.3ms (Typical)	0x13	37T = 99.9ms (Typical)	0x25	74T = 199.8ms (Typical)	0x4A	148T = 399.6ms (Typical)	0x94	255T = 688.5ms (Typical)	0xFF
Integration time (TIG)	TIG_SEL Value																				
1T = 2.7ms (Typical)	0x01																				
2T = 5.4ms (Typical)	0x02																				
19T = 51.3ms (Typical)	0x13																				
37T = 99.9ms (Typical)	0x25																				
74T = 199.8ms (Typical)	0x4A																				
148T = 399.6ms (Typical)	0x94																				
255T = 688.5ms (Typical)	0xFF																				
0x05	[7:0]	RW	0xFF	CGAIN	Current gain, CGAIN used to increase low light sensitivity <table border="1" style="margin-left: 20px;"> <thead> <tr> <th>Current gain (CG)</th> <th>CGAIN Value</th> </tr> </thead> <tbody> <tr> <td>x1</td> <td>0x11</td> </tr> <tr> <td>x2</td> <td>0x22</td> </tr> <tr> <td>x3</td> <td>0x33</td> </tr> <tr> <td>.</td> <td>.</td> </tr> <tr> <td>.</td> <td>.</td> </tr> <tr> <td>..</td> <td>..</td> </tr> <tr> <td>x15</td> <td>0xFF</td> </tr> </tbody> </table>	Current gain (CG)	CGAIN Value	x1	0x11	x2	0x22	x3	0x33	x15	0xFF
Current gain (CG)	CGAIN Value																				
x1	0x11																				
x2	0x22																				
x3	0x33																				
.	.																				
.	.																				
..	..																				
x15	0xFF																				
0x06	-	-	-	-	Reserved																
-	-	-	-	-	Reserved																
0x0F					Reserved																

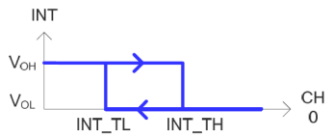
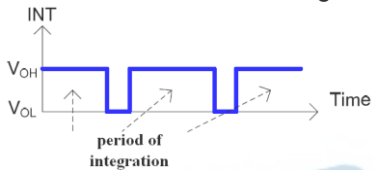
0x10	[7:0]	RW	0x00	INT_CTL	Interrupt control
	[7:5]	RW	0	-	Reserved. The field is always 0.
	[4:3]	RW	0	INT_MOD	<p>Interrupt mode Interrupt's source is CH0, and has 4 interrupt mode: 0: Hysteresis interrupt</p>  <p>1: Reserved 2: Level interrupt When CH0[15:0] <= INT_TL[15:0], interrupt occurs. And user should write INT_CLR to clear it. 3: Pulse interrupt The interrupt flag occurs on no-integrated period to inform micro-controller to read register 0x20~0x24, so it occurs periodically.</p> 
	2	RW	0	INT_PO	<p>Interrupt pole 0: Active low 1: Active high</p>
	1	RW	0	INT_ENH	<p>Interrupt disable /enable 0: Disable 1: Enable</p>
	0	RW	0	INT_CLR	Interrupt clear, only works on mode2 (level interrupt) of INT_MOD .
0x11	[7:0]	RW	0xD0	INT_THL	Interrupt high threshold, Low byte
0x12	[7:0]	RW	0x07	INT_THH	Interrupt high threshold, High byte
0x13	[7:0]	RW	0xE8	INT_TLL	Interrupt low threshold, Low byte
0x14	[7:0]	RW	0x03	INT_TLH	Interrupt low threshold, High byte
0x20	[0]	RO	-	UPDATE	<p>User should read this register first for updating following register 0x21~0x24. When micro-controller read this register, the shortest period must be longer than integration time (TIG').</p>
0x21	[7:0]	RO	-	CH0_LB	ADC channel 0, Low byte
0x22	[7:0]	RO	-	CH0_HB	ADC channel 0, High byte
0x23	[7:0]	RO	-	CH1_LB	ADC channel 1, Low byte
0x24	[7:0]	RO	-	CH1_HB	ADC channel 1, High byte

Note: RO = Read Only; RW = Read/Write. Reserved bytes must not be accessed otherwise unpredictable results may occur.

Basic Operation

After starting the device, user first write **PD=1** to power down the device. User could set the device to active mode by writing **PD=0**. To operate the device in active mode, issue a command to access the **UPDATE** register. User should read this register first for updating following register 0x21~0x24. When micro-controller read the **UPDATE** register, the shortest period must be longer than integration time (TIG'). The integration time is 400ms (default value). After 400 ms, the conversion results will be available in the **CH0** (register 0x21~0x22) and **CH1** (register 0x23~0x24).

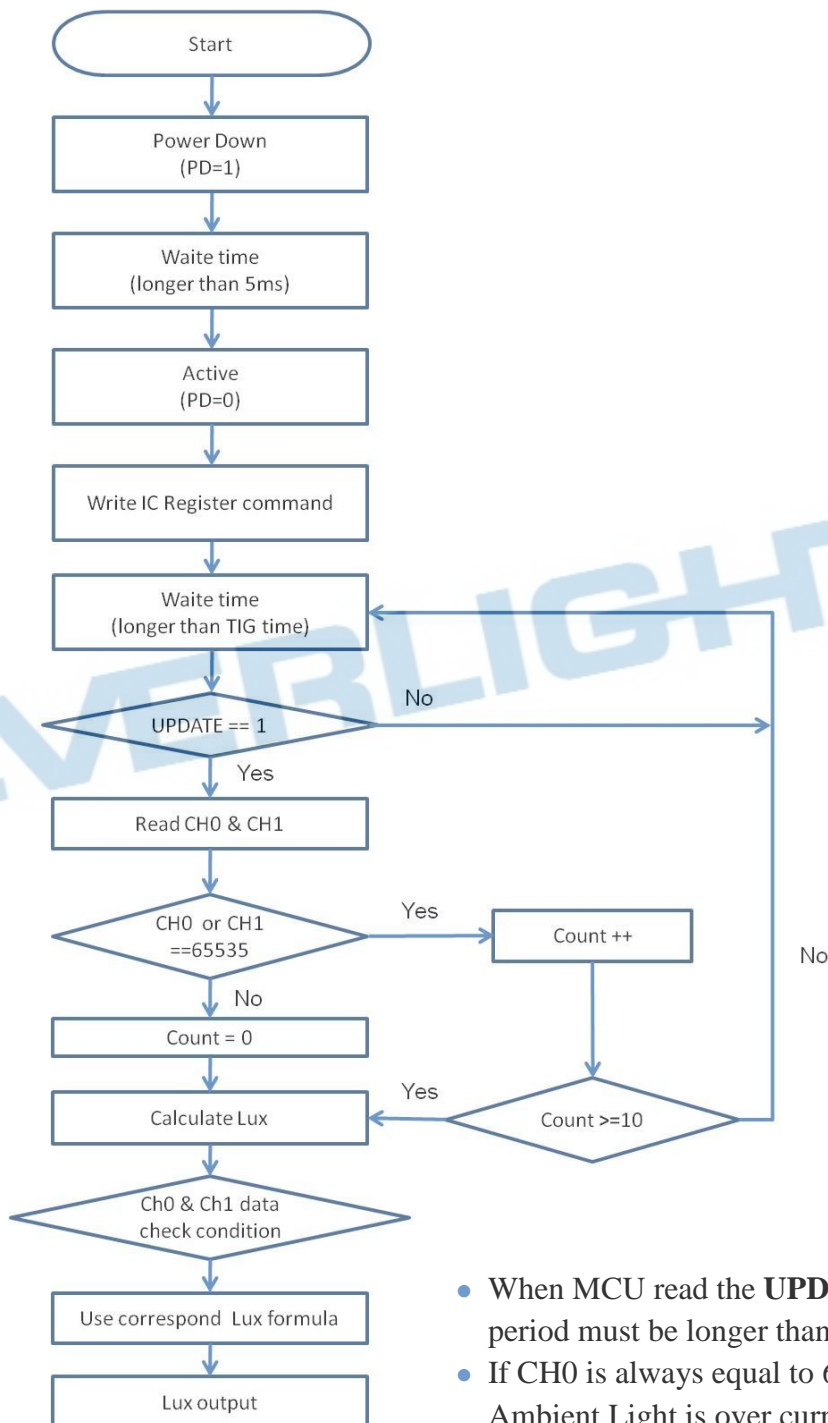

- When MCU read the **UPDATE** register, the shortest period must be longer than integration time(TIG').
- If CH0 is always equal to 65535, that means the Ambient Light is over current range.

Lux Calculating

User could calculate lux value by using the following equation (for white LED)

- if $CH0 > CH1$, $Lux = (CH0 - CH1) \times (15 / CG) \times (148 / TIG) \times K$
- else if $(CH0 > (CH1 * CH1K))$, $Lux = (CH0 - (CH1 * CH1K)) \times (15 / CG) \times (148 / TIG) \times K$
- else $Lux = (CH0) \times (15 / CG) \times (148 / TIG) \times CH0K$

Recommend Calibrate value : $K = 0.009$, $CH1K=0.93$, $CH0K =0.0013$

Note: **CG** range is 1~15.

VDD Power-up and Power Supply

Upon power-up, please ensure the slew rate of VDD greater than 1.0 V/mS. After power-up, the supply voltage shall NOT drop below 2.0V. Once it happens, please switch off the power, wait more than 1 second, and then power on the device again.

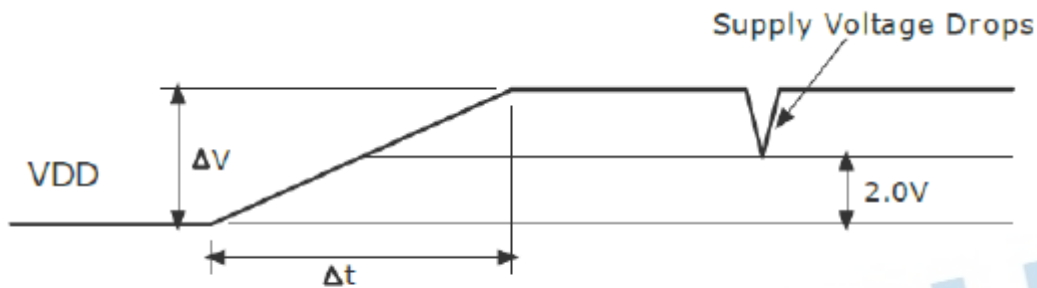

$$\text{Slew Rate} = \frac{\Delta V}{\Delta t} > 1.0 \text{ V/mS}$$

EVERLIGHT

Package Outlines (Unit: mm)

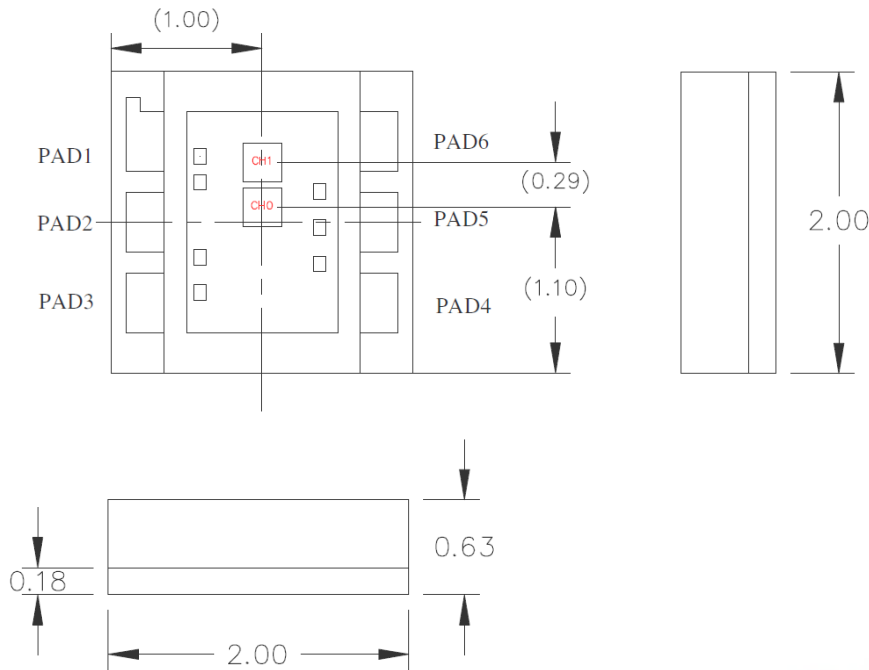

Pad Number	Pad Name
1	VDD
2	ADDR
3	VSS
4	SCL
5	INT
6	SDA

Pad Number	Pad Size(μ m)
CH0	256.6*256.6
CH1	256.6*256.6

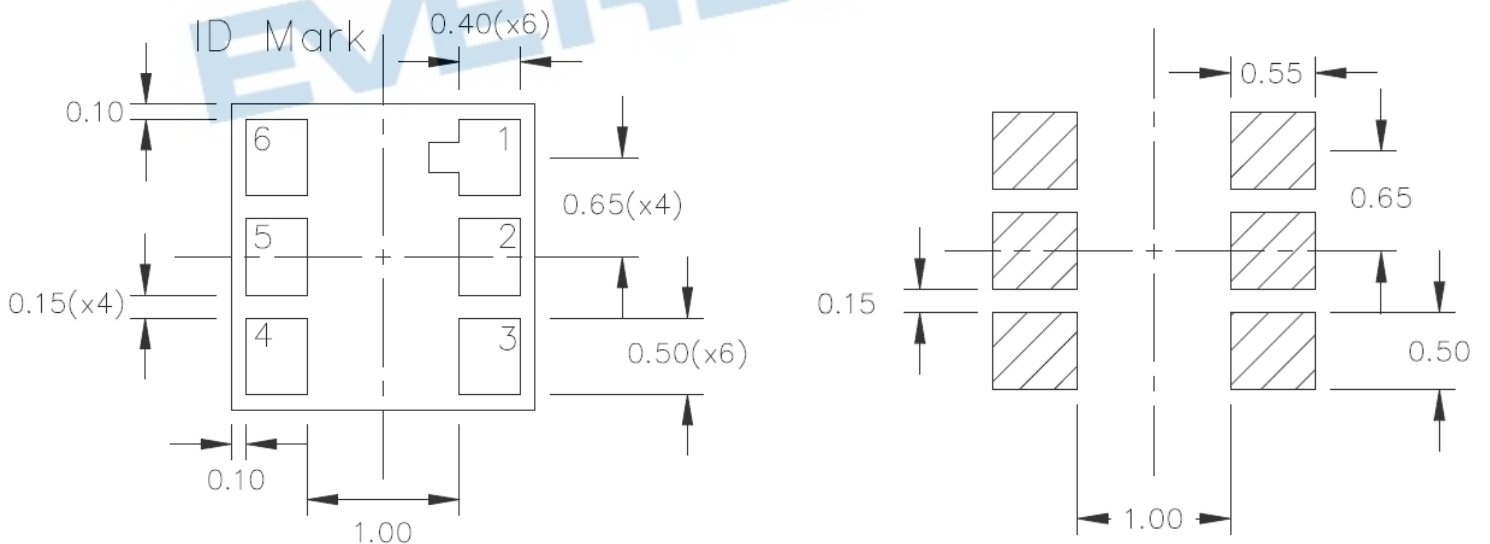

recommend soldering pattern

Note: Tolerances unless mentioned ± 0.2 mm. Unit = mm

Recommended method of storage

1. Do not open moisture proof bag before devices are ready to use.
2. Shelf life in sealed bag from the bag seal date: 18 months at 10°C~30°C and < 90% RH.
3. After opening the package, the devices must be stored at 10°C~30°C and ≤ 60%RH, and used within 168 hours (floor life).
4. If the moisture absorbent material (desiccant material) has faded or unopened bag has exceeded the shelf life or devices (out of bag) have exceeded the floor life, baking treatment is required.
5. If baking is required, refer to IPC/JEDEC J-STD-033 for bake procedure or recommend the following conditions:
 - 192 hours at 40°C +5/-0°C and < 5 % RH (reeled/tubed/loose units) or
 - 96 hours at 60°C ± 5°C and < 5 % RH (reeled/tubed/loose units) or
 - 24 hours at 125°C ± 5°C, not suitable for reel or tubes.

Recommended Solder Profile

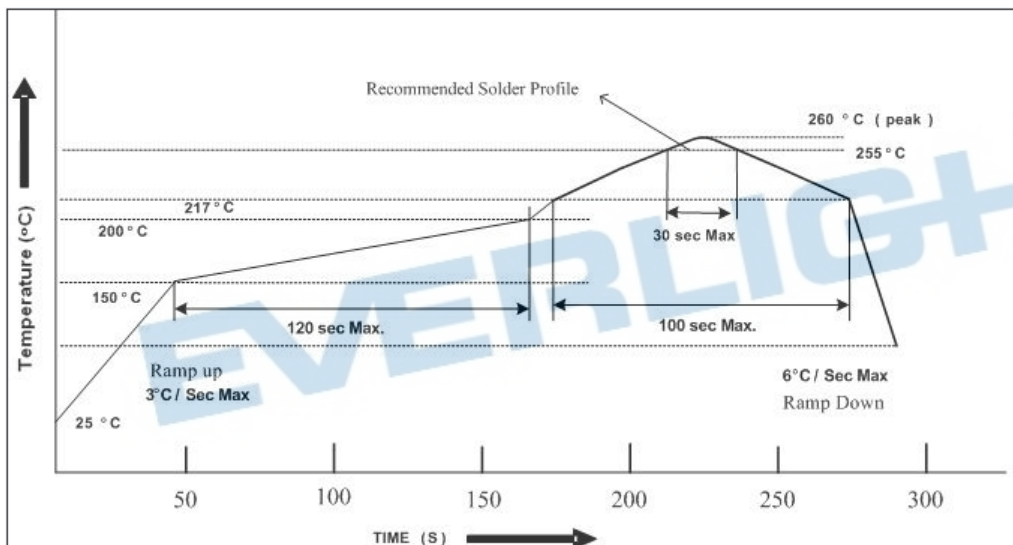

Notice:

- (1) Reflow soldering should not be done more than two times.
- (2) When soldering, do not put stress on the devices during heating.
- (3) After soldering, do not warp the circuit board.

Soldering Iron

Each terminal is to go to the tip of soldering iron temperature less than 350°C for 3 seconds within once in less than the soldering iron capacity 25W. Leave two seconds and more intervals, and do soldering of each terminal. Be careful because the damage of the product is often started at the time of the hand solder.

Repairing

Repair should not be done after the device have been soldered. When repairing is unavoidable, a double-head soldering iron should be used (as below figure). It should be confirmed beforehand whether the characteristics of the device will or will not be damaged by repairing.

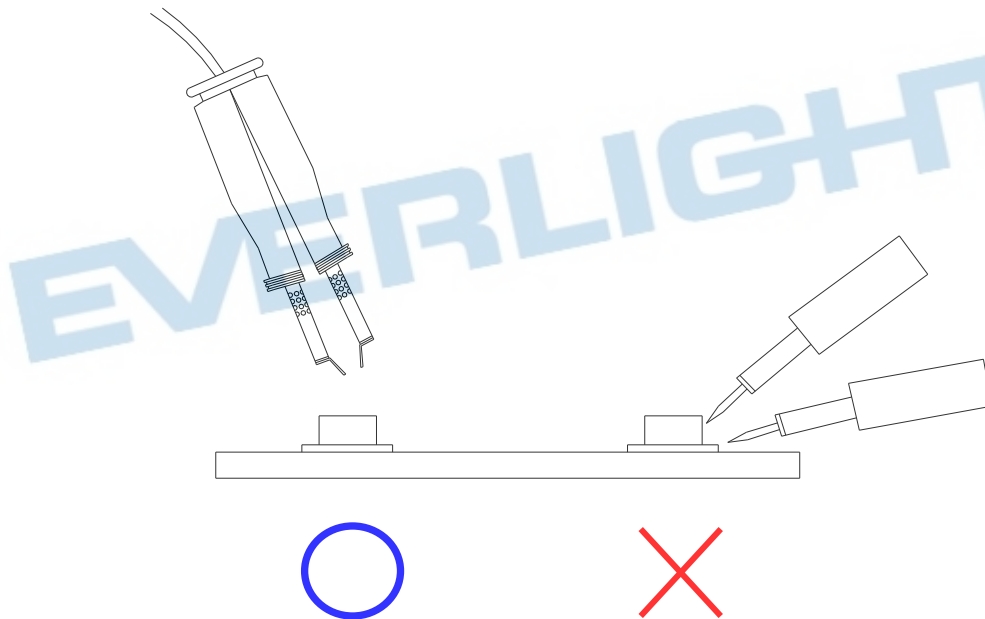

Label Explanation

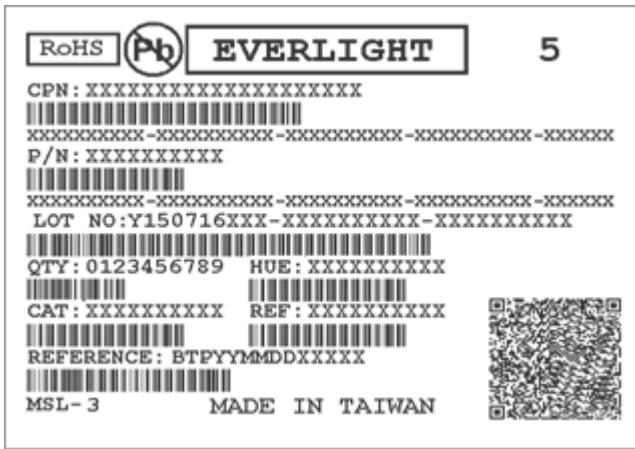

- CPN: Customer's Product Number
- P/N: Product Number
- QTY: Packing Quantity
- CAT: Luminous Intensity Rank
- HUE: Dom. Wavelength Rank
- REF: Forward Voltage Rank
- LOT No: Lot Number

Packing Quantity Specification

2000 PCS/ 1 Reel

Reel Dimensions

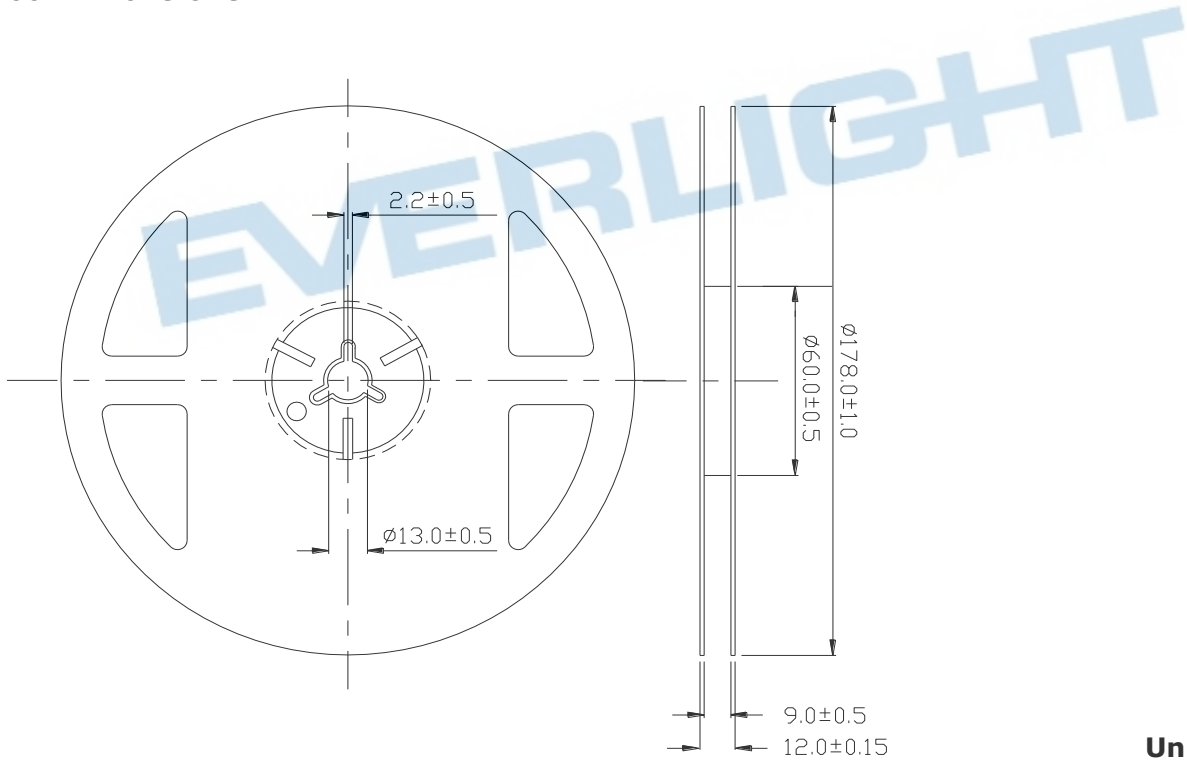

Unit: mm

Tape Dimensions

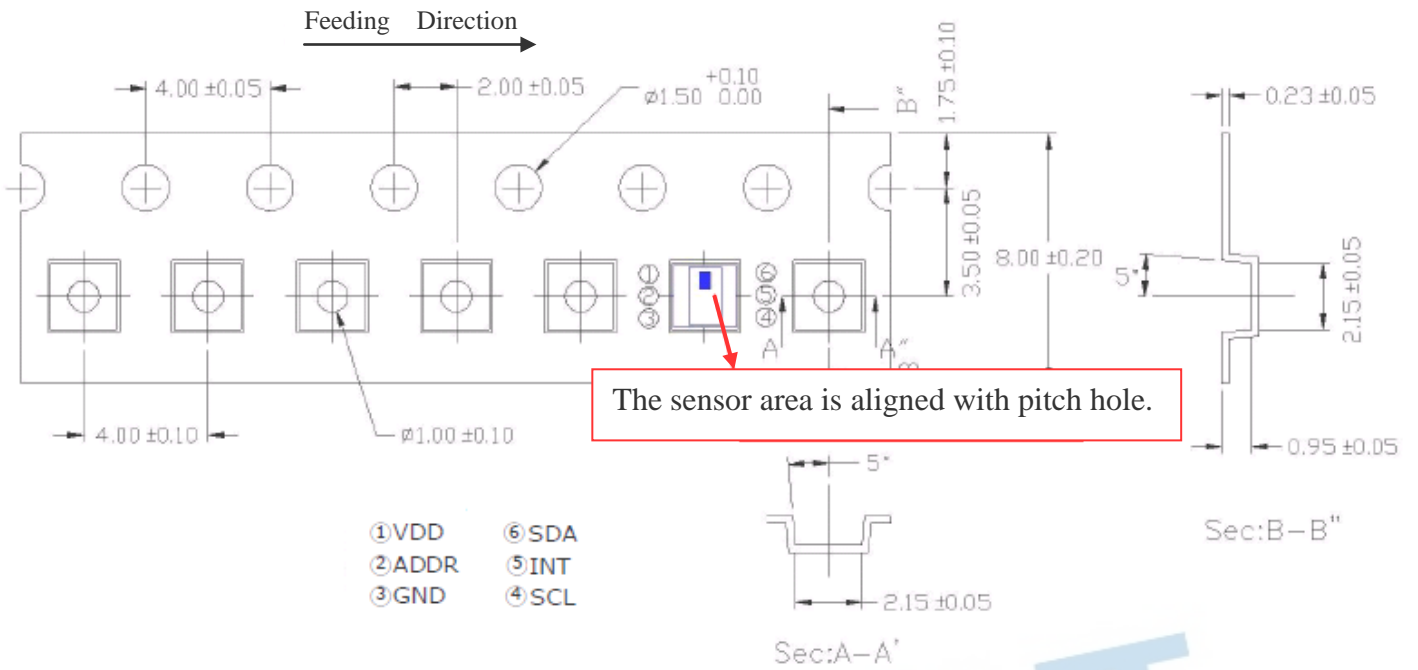

Unit: mm

Moisture Resistant Packing Process

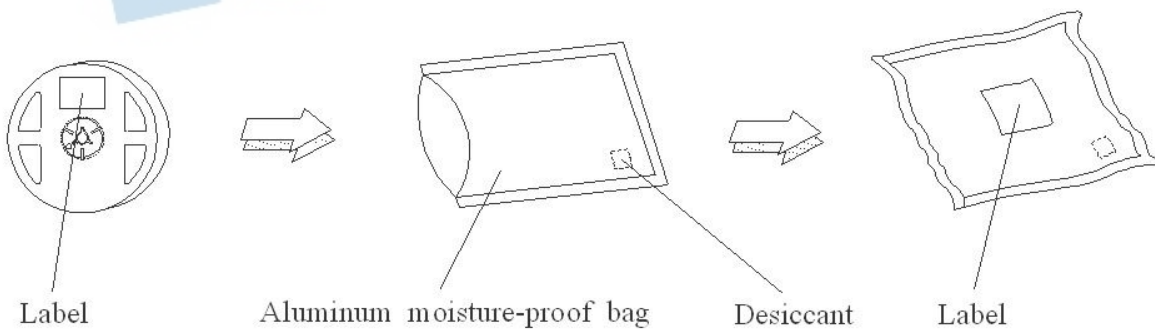

DISCLAIMER

1. EVERLIGHT reserves the right(s) on the adjustment of product material mix for the specification.
2. The product meets EVERLIGHT published specification for a period of twelve (12) months from date of shipment.
3. The graphs shown in this datasheet are representing typical data only and do not show guaranteed values.
4. When using this product, please observe the absolute maximum ratings and the instructions for using outlined in these specification sheets. EVERLIGHT assumes no responsibility for any damage resulting from the use of the product which does not comply with the absolute maximum ratings and the instructions included in these specification sheets.
5. These specification sheets include materials protected under copyright of EVERLIGHT. Reproduction in any form is prohibited without obtaining EVERLIGHT's prior consent.
6. This product is not intended to be used for military, aircraft, automotive, medical, life sustaining or life saving applications or any other application which can result in human injury or death. Please contact authorized Everlight sales agent for special application request.

EVERLIGHT