

Fusing time DIN ISO 8820-3 [s]		
Load [%]	Minimum [s]	Maximum [s]
100 %	360,000	-
135 %	60	900
160 %	10	200
200 %	2	60
350 %	0.2	7
600 %	0.04	1

Rating [ A ]	Color	Volt [ V ]	iMaXX Reference
20	Yellow	32	F9020
25	Grey	32	F9025
30	Green	32	F9030
40	Orange	32	F9040
50	Red	32	F9050
60	Blue	32	F9060
70	Brown	32	F9070
80	Natural	32	F9080
100	Violet	32	F9100

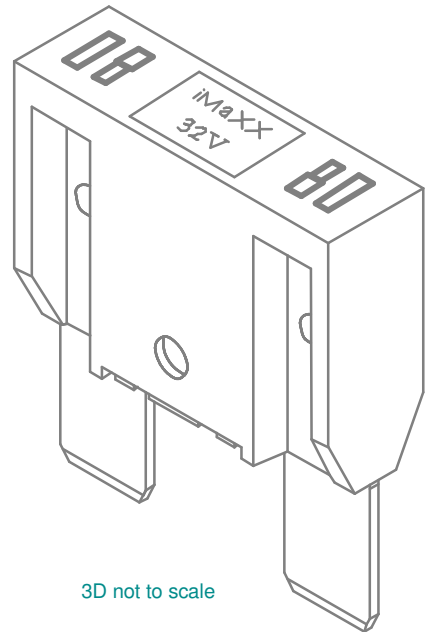

Revisions			Date	Appr.	
	Date	Type	Drawn	08/00	GRH
a	07/01	DIN nomenclature	Checked	10/12	EB
b	07/07	re-drawn	Standards		
c	07/10	corrected DIN dimension spec	Approved	10/12	AdH
d	12/10	added 25 amp			
e	07/11	updated DIN to ISO & add cavity #	Scale 2 : 1		
f	10/12	updated dimensions	Projection	Tolerance	
				± 0.2 mm unless otherwise noted	



Title	F9000 series, maxiOTO blade fuse
Drawing type	schematic
Drawing number	F9000 drawing 1
Sheet	1 of 1
Layers	0 1 2 6 9 11

