



亨龍工業有限公司

HANLONG INDUSTRIAL CO., LTD

NO.58 CHUNG SHAN RD., TU CHENG DISTRICT,  
NEW TAIPEI CITY 23680, TAIWAN

TEL: 886-2 2267-6700 FAX: 886-2-22676757  
E-mail: hanlong@hanlong.com.tw.

## HT-236U RATCHET CRIMPING TOOL

### SPECIFICATION:

\* **Item No** : HT-236U

\* **Function** :

Non-Insulated ,Open Barrel & D-sub,V.35 Terminal  
AWG 14/22

DIN 2.5-0.5 mm<sup>2</sup>

\* **Length** : 8.7"(220mm)

\* **Weight** : 500g

\* **Material** :

Frame – Middle Carbon Steel .

Crimper- Made Of Off Wax.

\* **Finished** :

Black Oxide Finished With hardened

Crimper

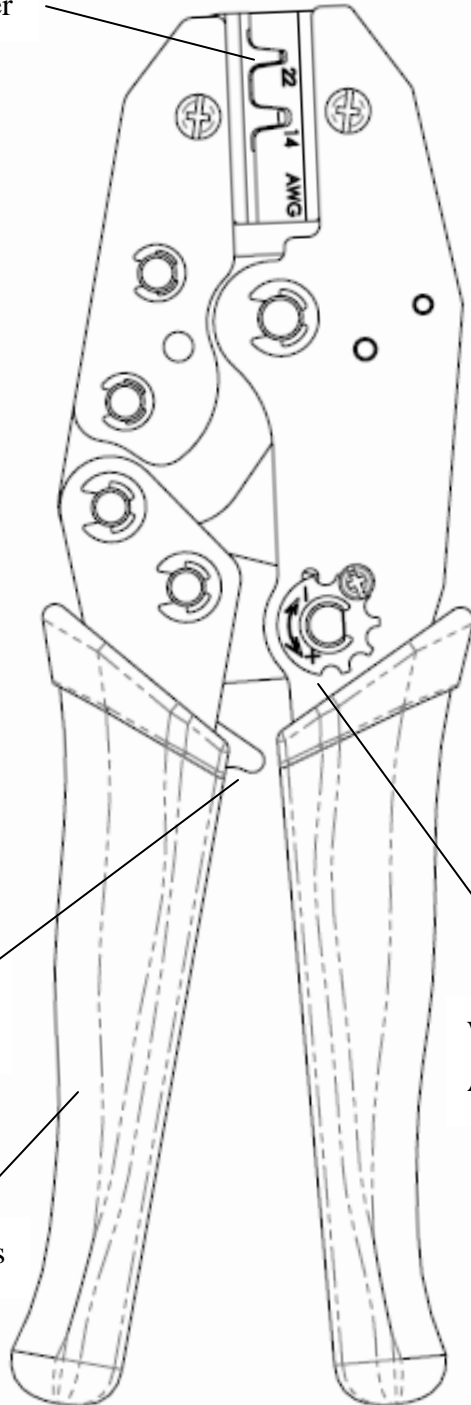

Ratchet  
Release

PP Handles

With  
Adjusting Disc



15/05/22

SANDY
