

產品確認書

PRODUCT SPECIFICATION

品名

TITLE: TOGGLE SWITCH 1P3T

型號

MF CODEL: WT-13I04-T(P1)17.4

所屬部門

DEPARTMENT: _____

內容頁數

CONTENT: 3 SHEETS

本司存檔號

OUR REF. NO: _____

貴司存檔號

YOUR REF. NO: _____

日期

DATE: 2023-4-17

客戶承認印鑑 CUSTOMER APPROVAL

審核人

APPROVED BY: _____

日期

DATE: _____

蓋章 ISSUED

請確認規格后簽回

PLEASE SIGN RETURN AFTER APPROVED

日進工業有限公司 (1973年成立)

Promotive Industrial Co.,Ltd. (Established in 1973)

香港荃灣沙咀道 52 號 A 皇廷廣場 33 字樓

33/F, King Palace Plaza, 52A Sha Tsui Road, Tsuen Wan, Hong Kong

Tel: (852) 2408 6681 Fax: (852) 2409 5086

http://www.pic.com.hk http://www.hkpic.com

東莞日進電子有限公司

DongGuan Promotive Electronics Co.,Ltd



ISO9001:2015

00121Q39833R5M/4400

PIC MODEL NO. : WT-13I04-T(P1)17.4 (WT13)

REF. No. : PIC23007S

CUSTOMER NAME : Schukat electronic Vertriebs GmbH

ISSUE DATE : 17-Apr-23

A. GENERAL

A.1	NUMBER OF POLE	1
A.2	NO. OF THROW	3
A.3	TRAVEL	26°
A.4	NO. OF TERMINAL ROW	1
A.5	TERMINAL PITCH	4.6/9.2
A.6	TIMING	SCHEMATIC
A.7	KNOB (STYLE OR COLOR)	T(P1)17.4
A.8	CONTACT TYPE	CONTACT PLATE
A.9	MOUNTING TYPE	WIRING
A.10	TERMINAL PLATING	SILVER
A.11	FRAME PLATING	NICKEL
A.12	PRACTICAL TEMPERATURE RANGE	- 10 - +60 °C

B. ELECTRICAL PERFORMANCE

	PROPERTY	TEST CONDITION	PERFORMANCE
B.1	RATING	AC 125V 3A	
B.2	CONTACT RESISTANCE	DC 5V 1 Amp AT 1 KHz ± 200Hz (MAX 20mV, 50mA)	NOT MORE THAN 30 mOHM
B.3	INSULATION RESISTANCE	MEASURING BETWEEN ALL THE ADJACENT TERMINALS AND BETWEEN THE TERMINAL AND THE SHELL AT DC 500V FOR 1 MINUTE ± 5 SECONDS.	MORE THAN 100 Mohm
B.4	WITHSTAND VOLTAGE	MEASURING BETWEEN ALL THE ADJACENT TERMINALS AND BETWEEN THE TERMINAL AND THE SHELL AT AC 1000V (50-60Hz) FOR 1 MINUTE.	NO BREAKING

C. MECHANICAL PERFORMANCE

C.1	OPERATION FORCE	TEST AT THE ROOT OF THE LEVER.	150-450 gm-force
C.2	TERMINAL STRENGTH	APPLY A 500 gm STATIC FORCE IN ANY DIRECTION ON THE TIP OF THE TIP OF EACH FOR 1 MINUTE.	TERMINALS MA BE DEFORMED, BUT NO BREAKING OF TERMINALS AND CRACKING OF TERMINAL BASE.
C.3	LEVER STRENGTH	APPLY A 5 Kg STATIC FORCE IN THE DIRECTION OF OPERATION FOR 15 SECONDS.	THE LEVER SHALL NOT BE DEFORMED AND THE MECHANICAL FUNCTION SHALL WORK NORMALLY.
C.4	TERMINAL BASE STABILITY	APPLY A 5 Kg STATIC FORCE ON TOP THE LEVER NORMAL TO THE TERMINAL BASE IN 15 SECONDS.	THERE IS NO CRACKING OF TERMINAL BASE , AND STILL FIXED IN THE SHELL.
C.5	SOLDERING	TEMPERATURE OF SOLDER BY MANUAL : 260 ± 5 SOLDERING TIME : 5 ± 0.5 SECONDS	MORE THAN 75% OF THE DIPPED PART SHALL BE COVERED BY SOLDER.

PREPARED BY : DUAN LI LING

APPROVED BY : DLEREK LUI

PROMOTIVE INDUSTRIAL CO., LTD.

D. DURABILITY PAGE : 2/2

	<i>PROPERTY</i>	<i>TEST CONDITION</i>	<i>PERFORMANCE</i>
D.1	SWITCHING LIFE (WITH LOAD)	OPERATING FOR 10,000 CYCLES AT A RATE OF LESS THAN 10 CYCLES/MIN.	CONTACT RESISTANCE : NOT MORE THAN 500 mOhm. INSULATION RESISTANCE : MORE THAN 100 Mohm. WITHSTAND VOLTAGE : AC 1000V FOR 1 MINUTE. OPERATION FORCE : + 10%/-30% OF SPEC.. THERE SHALL BE NO DEFECTS IN APPEARANCE AND MECHANICAL FUNCTIONS.
D.2	SWITCHING LIFE (WITHOUT LOAD)	OPERATING FOR 100,000 CYCLES AT A RATE OF 15-18 CYCLES/MINUTE.	CONTACT RESISTANCE : NOT MORE THAN 500 mOhm. INSULATION RESISTANCE : MORE THAN 100 Mohm. WITHSTAND VOLTAGE : AC 1000V FOR 1 MINUTE. OPERATION FORCE : + 10%/-30% OF SPEC.. THERE SHALL BE NO DEFECTS IN APPEARANCE AND MECHANICAL FUNCTIONS.

E. WEATHER PROOF

E.1	COLD PROOF	SWITCH FOR TEST BEING KEPT IN THE CONDITIONS AT -20 ± 2 ° C IN TEMPERATURE FOR 96 HOURS, AND IN A NORMAL AMBIENT CONDITION FOR ONE HOUR, THEN TO BE MEASURED WITHIN ONE HOUR. DROPS OF WATER BEING TAKEN AWAY.	CONTACT RESISTANCE : NOT MORE THAN 500 mOhm. INSULATION RESISTANCE : MORE THAN 100 Mohm. WITHSTAND VOLTAGE : AC 1000V FOR 1 MINUTE. OPERATION FORCE : + 10%/-30% OF SPEC..
E.2	HEAT RESISTANCE	SWITCH FOR TEST BEING KEPT IN THE CONDITIONS 85 ± 2 ° C IN TEMPERATURE FOR 96 HOURS, AND IN A NORMAL AMBIENT CONDITION FOR ONE HOUR, THEN TO BE MEASURED WITHIN ONE HOUR. THEN TO BE MEASURED WITHIN 7	THERE SHALL BE NO DEFECTS IN APPEARANCE AND MECHANICAL FUNCTIONS.
E.3	RESISTANCE TO HUMIDITY	SWITCH FOR TEST BEING KEPT IN THE CONDITIONS AT 40 ± 2 ° C IN TEMPERATURE AND 90-95% RH FOR 96 HOURS, AND IN A NORMAL AMBIENT CONDITION FOR 1 HOUR, THEN TO BE MEASURED WITHIN ONE HOUR. DROPS OF WATER BEING TAKEN AWAY.	CONTACT RESISTANCE : NOT MORE THAN 500 mOhm. INSULATION RESISTANCE : MORE THAN 100 Mohm. WITHSTAND VOLTAGE : AC 1000V FOR 1 MINUTE. OPERATION FORCE : + 10%/-30% OF SPEC.. THERE SHALL BE NO DEFECTS IN APPEARANCE AND MECHANICAL FUNCTIONS.

F. TEST AND MEASURING CONDITION

TEMPERATURE	: 5-35 ° C
HUMIDITY	: 45-85% RH
PRESSURE	: 860-1060 mbar
ASSURING THE DOUBTFUL POINTS IN MEASUREMENT, TEST UNDER CONDITIONS OF	
TEMPERATURE	: 20 ± 5 ° C
HUMIDITY	: 75 ± 10 % RH
PRESSURE	: 860-1060 mbar

NOTE : SPECIFICATION SUBJECT TO CHANGE FOR IMPROVEMENT.

PIC



SCHMATIC

CENTER OFF

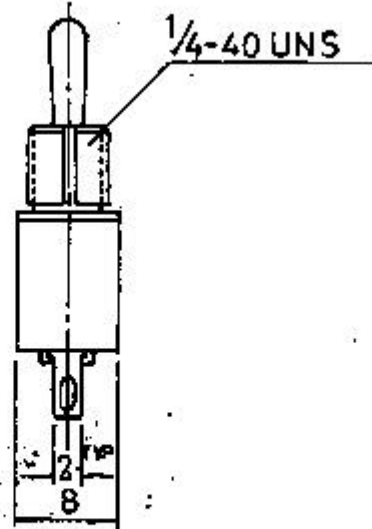
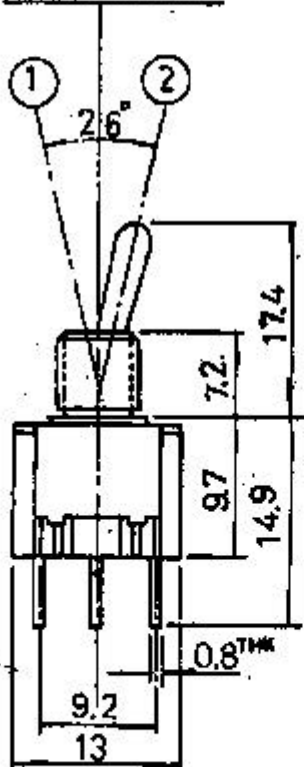

ISSUED	SPECIFICATION (INITIAL)	TITLE: TOGGLE SWITCH 1P3T			
	RATING: AC 125V 3A	MODEL NO: WT-13104-T(P)17.4			
	CONTACT RESISTANCE: Not more than 30mΩ (initial)	UNIT: mm	DWN	Saw	4/4/89
	INSULATION RESISTANCE: 100MΩ AT 500V DC	SCALE: 2:1	CHK'D	MA	12-4
	WITHSTAND VOLTAGE: AC 1000V FOR 1 MIN	OPERATION FORCE: 300 ± 150g	TOLERANCE: ±0.2	APPD.	1/2/89 1-31
	SWITCHING LIFE: 10K Cycles (5-15% unloading)				
BY:	PROMOTIVE INDUSTRIAL CO., LTD. HONG KONG			DRWG NO: 890079	
DATE: 25 FEB 1994					