

Product Specification

Abundance Enterprise Co.

Original Date

1/12/2005

PN:

ZM206E



# AEC<sup>®</sup>

Abundance Enterprise Co.

## PRODUCT SPECIFICATION

### CRYSTAL RESONATOR

**AEC PART NUMBER / SPEC. NO:** ZM206E-32.768K-20-12.5p

**CUSTOMER:** Schukat electronic Vertriebs GmbH



This model is ROHS/PB compliance according to the ROHS directive 2002/95/EC

RoHS Compliant

It has lead in high melting temperature solder inside exempted from ROHS directive Annex Article 4(1) point 7

<b>Production Name</b>	Crystal Resonator
<b>Frequency</b>	32.768KHz
<b>Model No</b>	ZM206E-32.768K-20-12.5p
<b>Issue Date</b>	18 <sup>th</sup> Jan 2013

Address: Room 602-603, Java Commercial Centre,

128 Java Road,

North Point, Hong Kong

Homepage: <http://www.aeccrystal.com/>

Email: sales@aeccrystal.com

Telephone: (852)-28560000

Fax (852) 2561 2161

Prepared	Inspection	Approved
<i>Victor</i>	<i>Andy</i>	<i>Henkie</i>

Product Specification	Abundance Enterprise Co.	Original Date	1/12/2005
		PN:	ZM206E

## 1. GENERAL PROVISION

- 1-1 Production Name: SMD Crystal Resonator
- 1-2 Holder Type: ZM206E
- 1-3 This specification relates to the crystal resonator to be supplied by Abundance Enterprise Co. ( AEC ).

## 2. ELECTRICAL DATA

Items	Parameters	Condition
2-1	Frequency:	32.768Khz
2-2	Tolerance of Center Frequency:	+/- 20 ppm at 25°C
2-3	Operating Temperature Range:	-40 °C to 85 °C
2-4	Storage Temperature Range:	-55°C to +125°C
2-5	Equivalent Series Resistance:	50KΩ max.
2-6	Load Capacitance:	12.5 pF
2-7	Shunt Capacitance (C <sub>0</sub> )	1.6pF typ
2-8	Motional Capacitance (C <sub>1</sub> )	3.3fF typ
2-9	Drive Level:	1uW max
2-10	Aging: Less than	+/- 3 ppm per year
2-11	Insulation Resistance:	More than 500M ohms at DC 100V
2-12	Test: Measured CAN-LF $\pi$ Network analysis.	

### 3. Frequency Characteristic

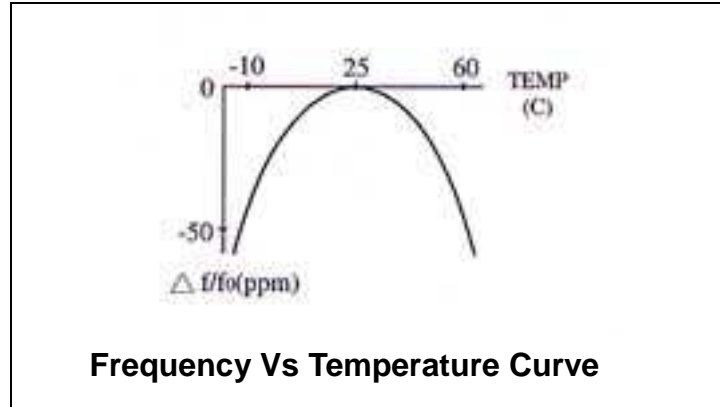

### 4. Packing Dimension

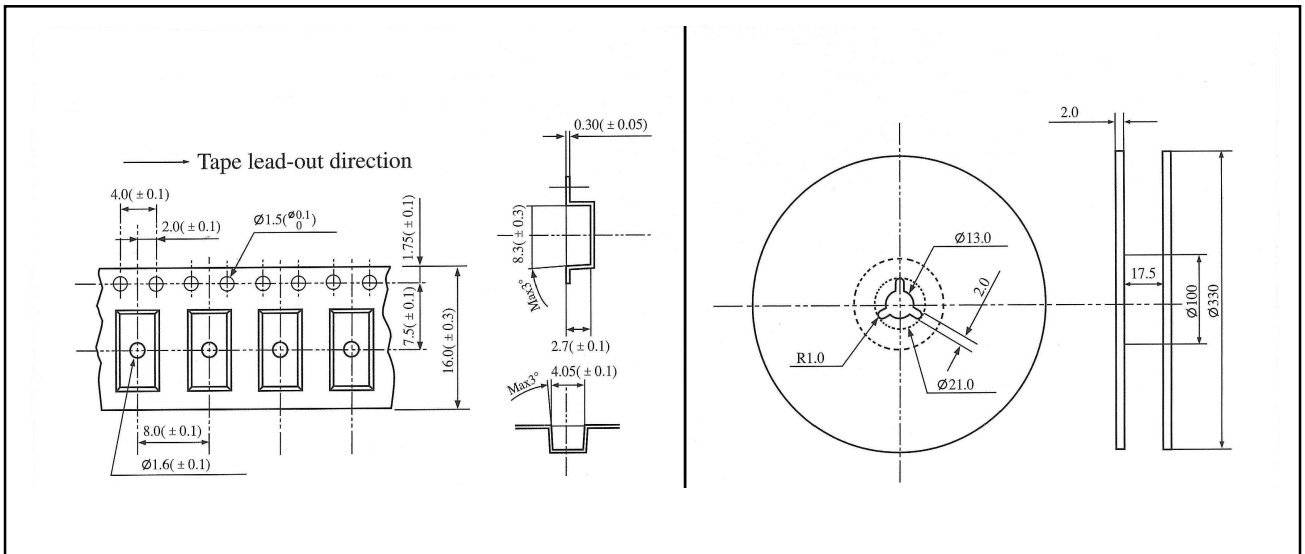

5. DIMENSION & LAND PATTERN

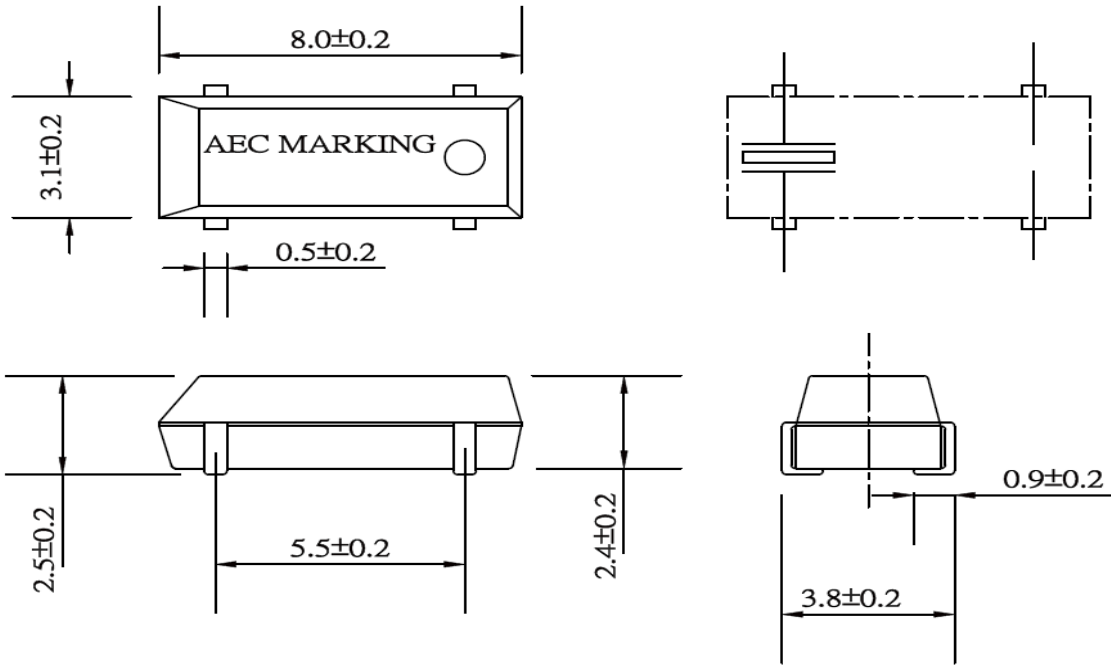

RECOMMENDED SOLDERING PATTERN

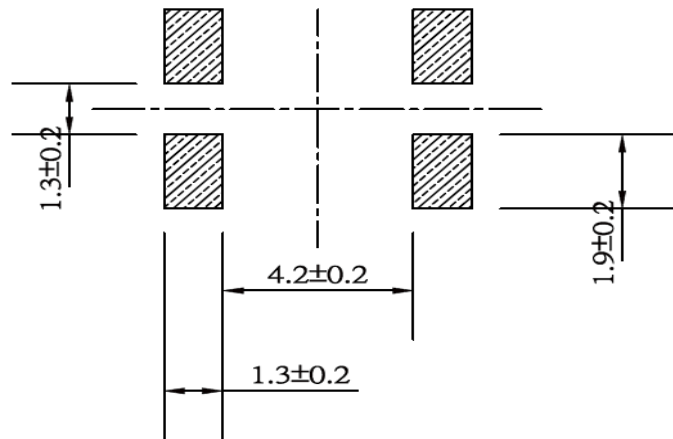

Unit: mm

<p><b>AEC</b><sup>®</sup> Abundance Enterprise Co.</p>	NO.	REVISED DATE	MODIFY CONTENTS		
	1	2005.12.1	ORIGINAL		
DIMENTION	mm				
SCALE		MODEL	PAD AND PRODUCT DIMENTION		
TOLERANCE	±0.2	PART NAME	ZM206E		
DRAWING NO.		APPV'D BY	CHECK BY	DRAWN BY	
<b>ZM206E</b>		Henkie	Andy	Teddy	

**6. REFLOW SOLDERING DIAGRAM**

