

BP-LFP

LiFePO4 battery packs

- ✓ Long-life battery pack
- ✓ High reliability
- ✓ Safe lithium iron phosphate technology
- ✓ 100% free of lead and cadmium
- ✓ Extended temperature range
- ✓ High performance BMS system
- ✓ Advanced charging algorithms and cell balancing
- ✓ Battery relax mode for lifetime extension
- ✓ Integrated protection against deep discharge, over current, over voltage and short circuit
- ✓ Compact shrink tube version
- ✓ UN 38.3 transportation certification



Technical data	
Nominal capacitance	2500 mAh
Technology	LiFePO4 (Lithium iron phosphate)
Life cycles	>6000
Temperature	Operating: -20...+55 °C / Storage: -30...+55 °C
Communication	SMB

Product specific data		
P/N	BP-LFP-1025	BP-LFP-1325
UPS version	UPSI-1208	UPSI-2406
Nominal voltage	9.9 VDC	13.2 VDC
Number of used cells	3 cells, 1p3s, 2.5 Ah, 9.9V _{nom} , 26650	4 cells, 1p4s, 2.5 Ah, 13.2V _{nom} , 26650
Energy	25 Wh	33 Wh
ESR	45 mΩ	64 mΩ
Charge voltage	10.8V max.	14.4V max.
Charge current	4.5 A max.	4.5 A max.
Discharge current	15 A max.	15 A max.
Fuse	Littlefuse 1206, 25 A	Littlefuse 1206, 25 A
Humidity	Operating: 10...90% RH, non-condensing Storage: 10...80% RH, non-condensing	Operating: 10...90% RH, non-condensing Storage: 10...80% RH, non-condensing
Dimensions (WxDxH)	91 x 66 x 30 mm ±0.5 mm	110 x 66 x 30 mm ±0.5 mm
Weight (net)	~ 270 g	~ 355 g

Nominal backup time, measured at +21 °C			
	50 W	100 W	140 W
BP-LFP-1025	~ 25 min	~ 12 min	–
BP-LFP-1325	~ 33 min	~ 16 min	~ 12 min

Back up time depends on battery capacitance, load and temperature.
At very high or low temperatures a reduction of backup time occurs.

Optional Accessories

▷▷▷ For detailed information please visit our website www.bicker.de and refer to the article number.

PSZ-1074 | Mounting bracket

Mounting bracket for BP-LFP-1025/1325,
2-pieces set



Drawing BP-LFP-1025

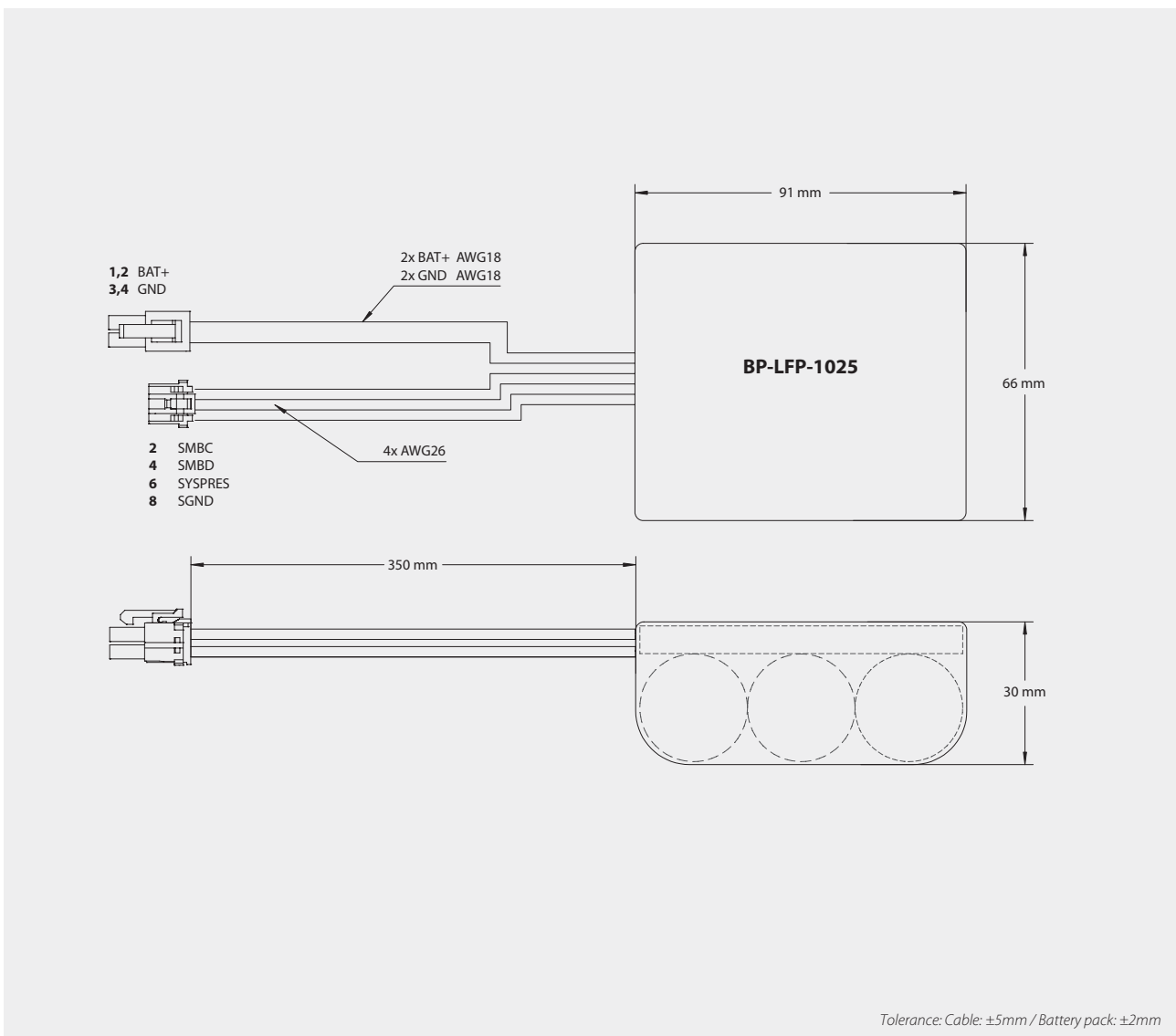

Drawing BP-LFP-1325

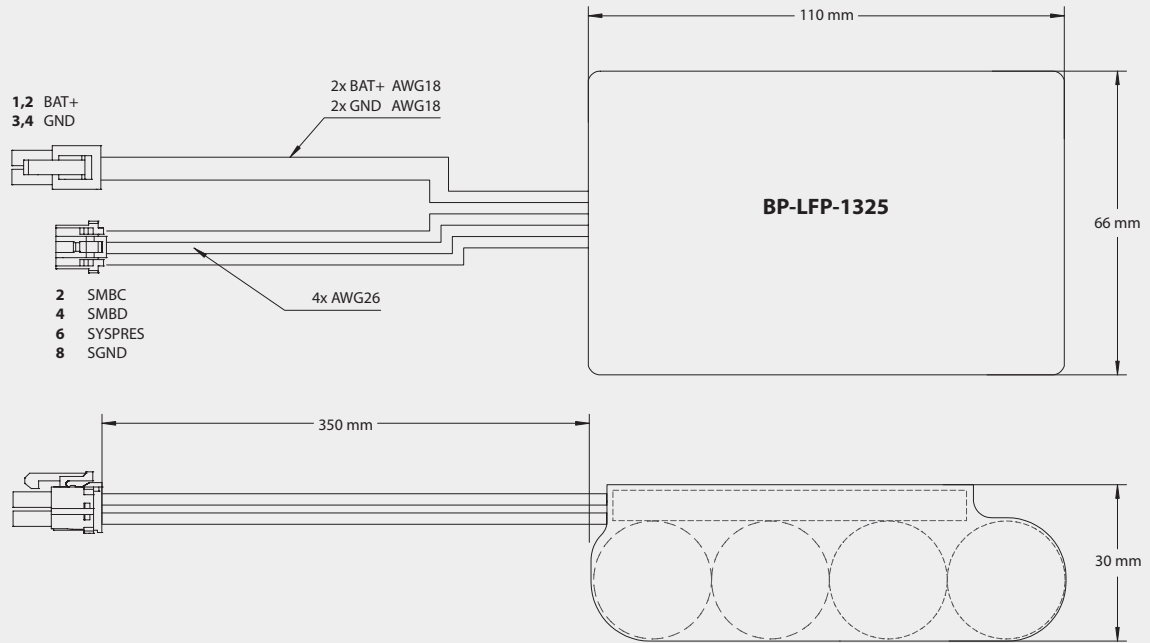

Tolerance: Cable: ±5mm / Battery pack: ±2mm

Backup time BP-LFP-1025

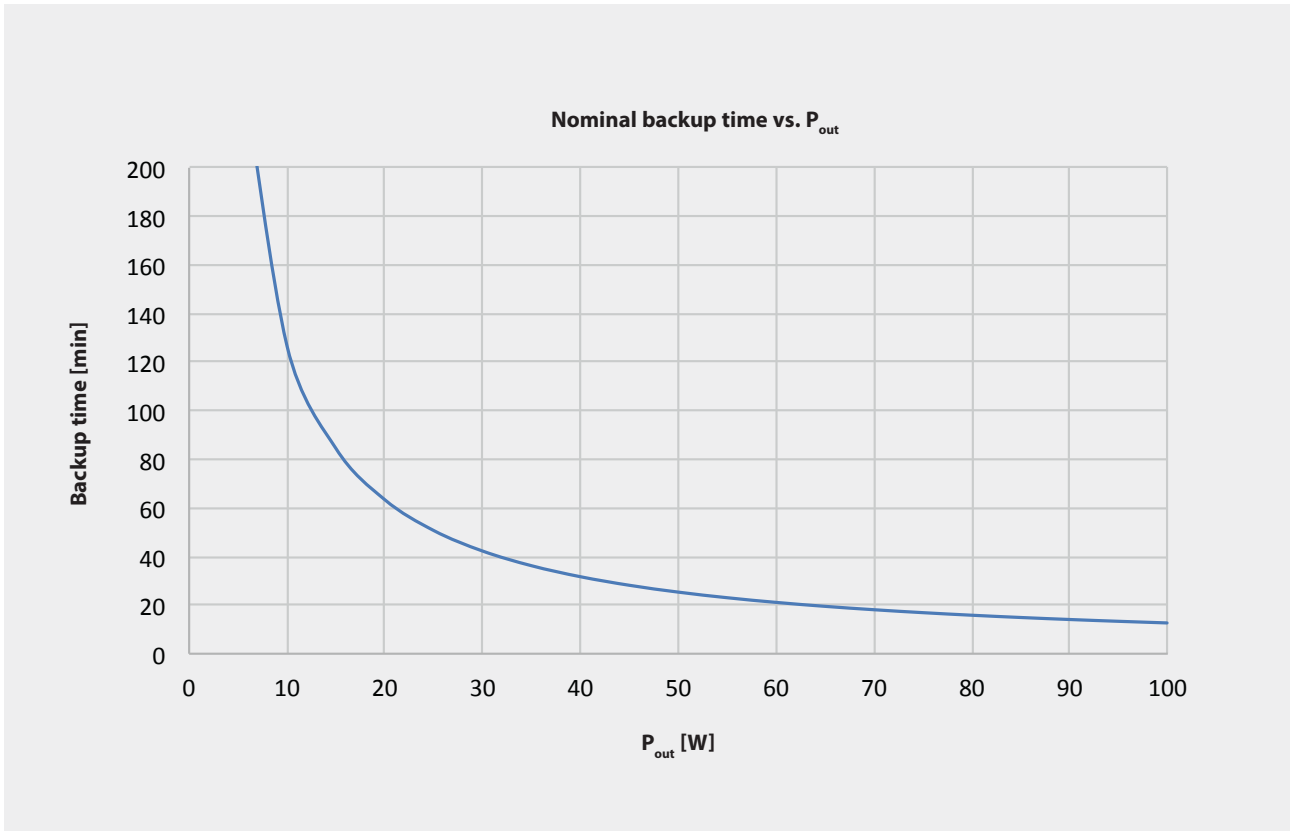

Backup time BP-LFP-1325

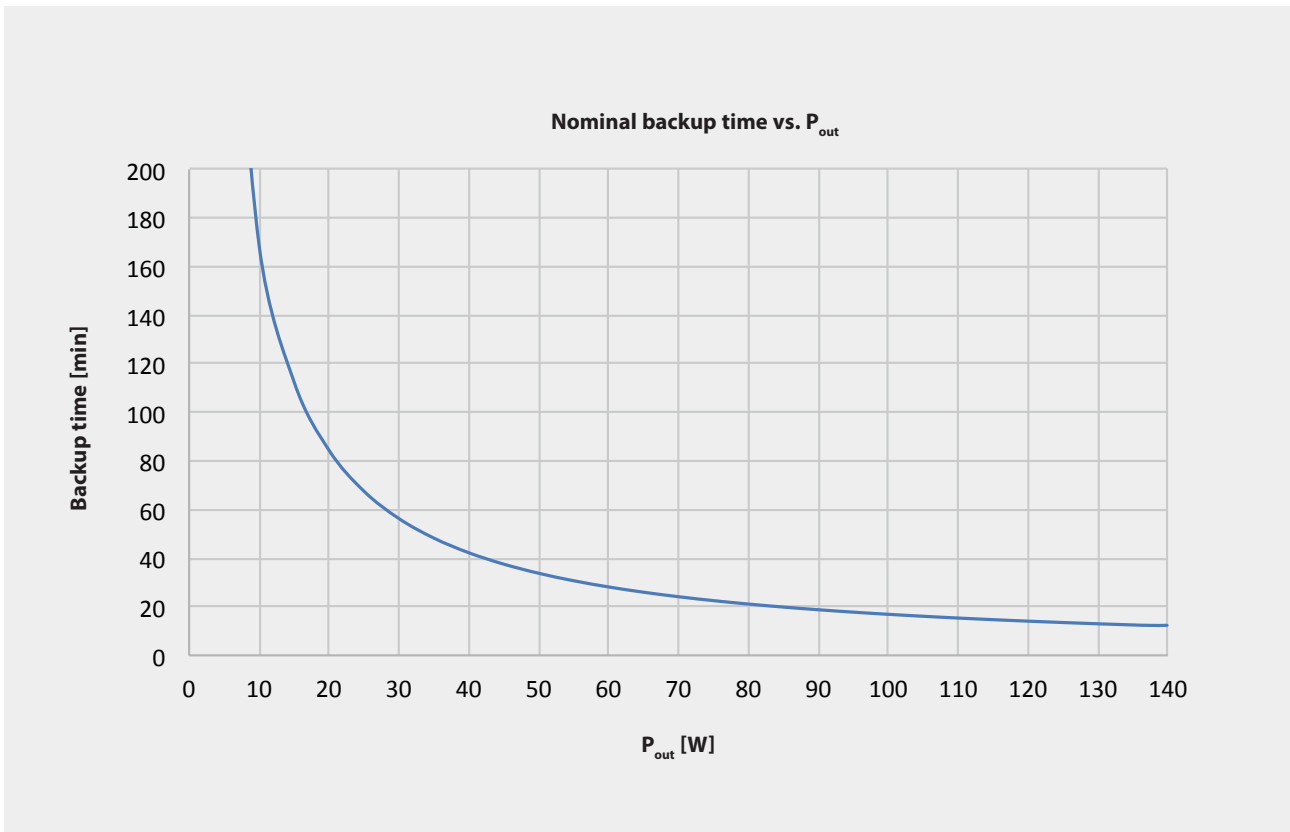

DC UPS

BP-LFP – LiFePO4 cell specifications

SPECIFICATION	VALUE
Nominal Voltage	3.3V
Nominal Capacity	2.5 Ah
Maximum discharge current - continuous (A)	40 A
Pulse discharge at 10 sec	70 A
Recommended standard charge	4 A to 3.5 V
Recommended fast charge	10 A to 3.5 V
Recommended float charge voltage	3.5 V
Recommended end of discharge cutoff	2.0 V
Absolute maximum cell temperature	85 °C (measured at cell surface)
Weight	75 g
Nanophosphate® Chemistry	M1-B
Current Interrupt Device (CID)	No

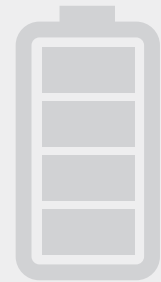

BP-LFP – Battery voltage and current during recharge

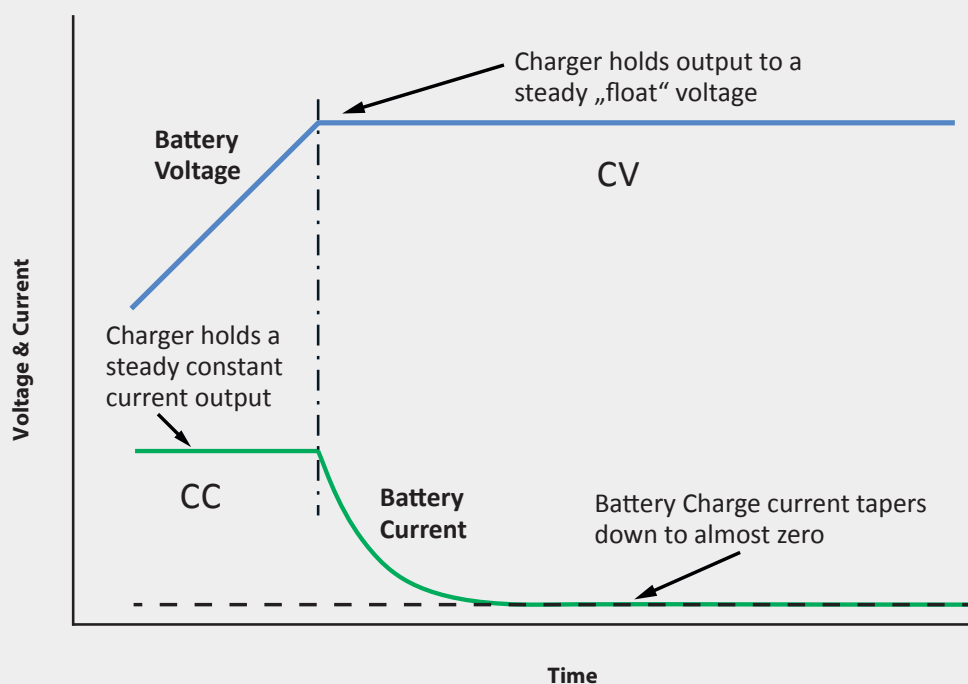

Safety information



Please consider to each country's own regulation about recycling and disposal of used batteries etc. in hazardous waste or resending to any recycling organization. The battery pack should not be exposed to fire, immersed under water, soldered, opened, short-circuited, reversed or overheated. During storage the battery pack should not be exposed to temperatures outside the specification and should not be pushed too heavy and not exposed to high pressure. Do not swallow any parts of the battery pack.

BP-LFP – Cycle life at various temperatures

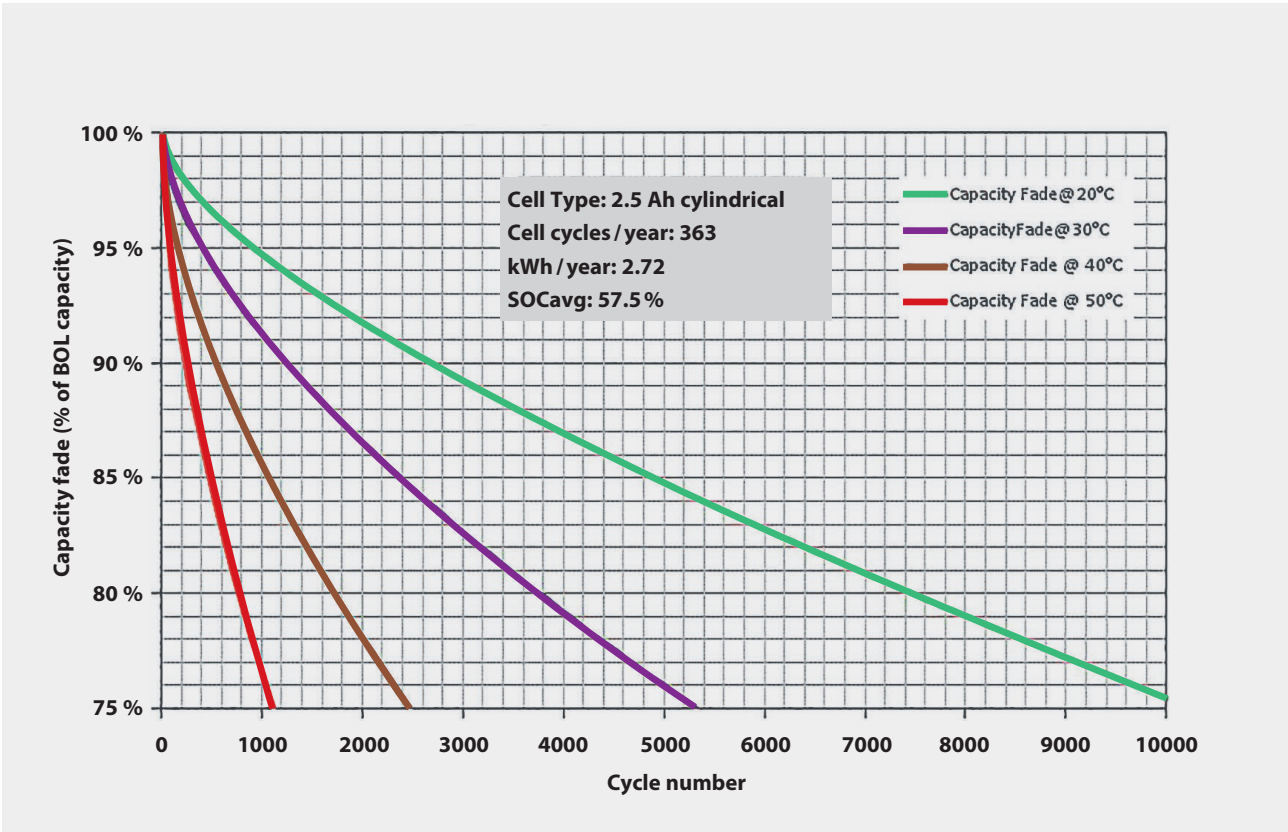

BP-LFP – Calendar life at various temperatures

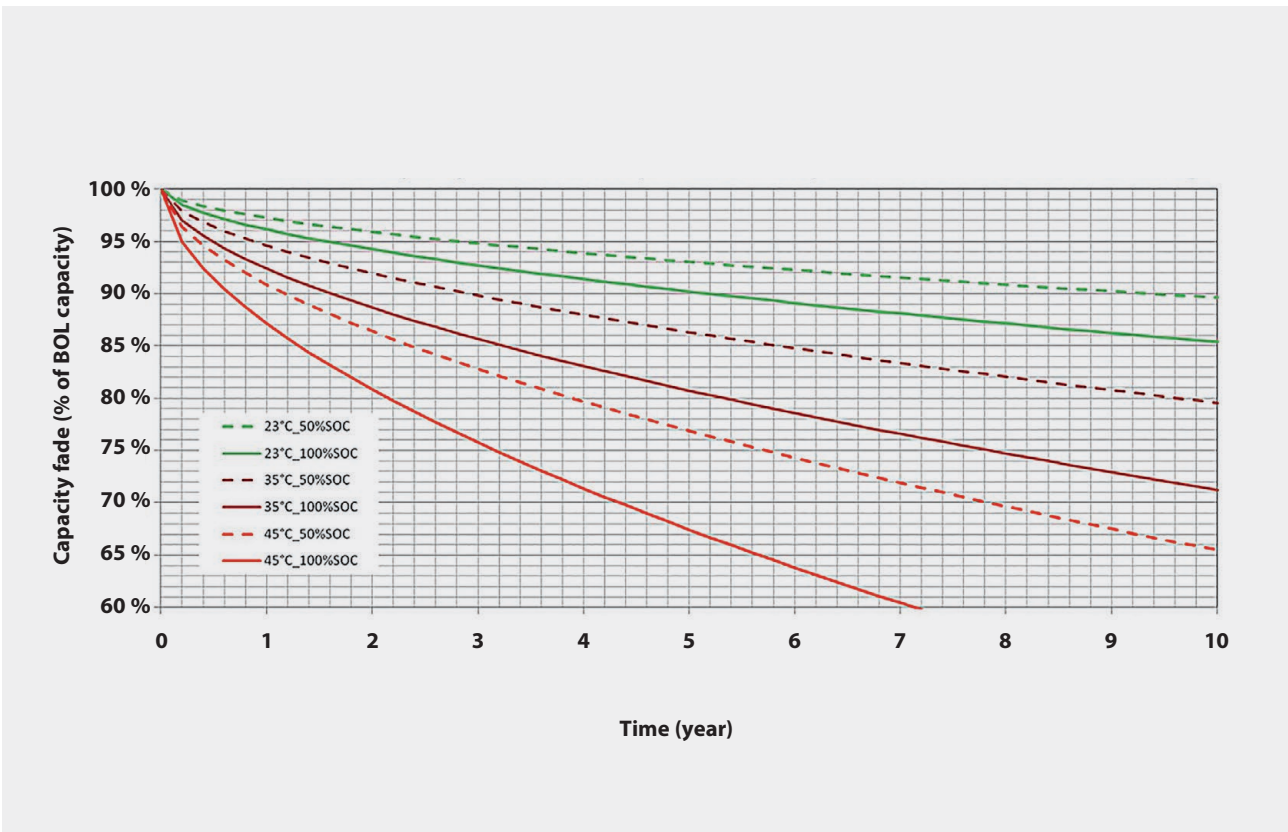

Specification is subject to change without notice. Errors excepted. Status as at: 08.07.2021

DC UPS