

# ESP8684-WROOM-02C

# ESP8684-WROOM-02UC

## Datasheet

2.4 GHz Wi-Fi (802.11 b/g/n) and Bluetooth® 5 module

Built around ESP8684 series of SoC, RISC-V single-core microprocessor

2 MB/4 MB flash in chip package

14 GPIOs

On-board PCB antenna or external antenna connector



ESP8684-WROOM-02C



ESP8684-WROOM-02UC



Version 0.6  
Espressif Systems  
Copyright © 2023

# 1 Module Overview

**Note:**

Check the link or the QR code to make sure that you use the latest version of this document:

[https://www.espressif.com/sites/default/files/documentation/esp8684-wroom-02c\\_datasheet\\_en.pdf](https://www.espressif.com/sites/default/files/documentation/esp8684-wroom-02c_datasheet_en.pdf)



## 1.1 Features

### CPU and On-Chip Memory

- ESP8684H2 or ESP8684H4 embedded, 32-bit RISC-V single-core processor, up to 120 MHz
- 576 KB ROM
- 272 KB SRAM (16 KB for cache)
- SiP flash (see details in Table 1 *Ordering Information*)
- Access to flash accelerated by cache
- Supports flash In-Circuit Programming (ICP)

### Wi-Fi

- IEEE 802.11 b/g/n-compliant
- Center frequency range of operating channel: 2412 ~ 2484 MHz
- Supports 20 MHz bandwidth in 2.4 GHz band
- 1T1R mode with data rate up to 72.2 Mbps
- Wi-Fi Multimedia (WMM)
- TX/RX A-MPDU, TX/RX A-MSDU
- Immediate Block ACK
- Fragmentation and defragmentation
- Transmit opportunity (TXOP)
- Automatic Beacon monitoring (hardware TSF)
- 3 × virtual Wi-Fi interfaces
- Simultaneous support for Infrastructure BSS in Station mode, SoftAP mode, Station + SoftAP mode, and promiscuous mode

*Note that when ESP8684 series scans in Station*

*mode, the SoftAP channel will change along with the Station channel*

### Bluetooth®

- Bluetooth LE: Bluetooth 5
- High power mode 20 dBm
- Speed: 125 kbps, 500 kbps, 1 Mbps, 2 Mbps
- Advertising extensions
- Multiple advertisement sets
- Channel selection algorithm #2
- Internal co-existence mechanism between Wi-Fi and Bluetooth to share the same antenna

### Peripherals

- GPIO, SPI, UART, I2C, LED PWM controller, general DMA controller, temperature sensor, SAR ADC, timers and watchdogs

### Integrated Components on Module

- 26 MHz crystal oscillator

### Antenna Options

- On-board PCB antenna (ESP8684-WROOM-02C)
- External antenna via a connector (ESP8684-WROOM-02UC)

### Operating Conditions

- Operating voltage/Power supply: 3.0 ~ 3.6 V
- Operating ambient temperature: -40 ~ 85 °C

## 1.2 Description

ESP8684-WROOM-02C and ESP8684-WROOM-02UC are two generic Wi-Fi and Bluetooth LE modules. The rich set of peripherals and high performance make the modules an ideal choice for smart homes, industrial automation, health care, consumer electronics, etc.

ESP8684-WROOM-02C comes with an on-board PCB antenna. ESP8684-WROOM-02UC comes with a connector for an external antenna. Both ESP8684-WROOM-02C and ESP8684-WROOM-02UC are available in two variants that integrate the ESP8684H2 and ESP8684H4 chip respectively. The ordering information for the two modules is as follows:

**Table 1: Ordering Information**

Ordering code	Chip embedded	SiP Flash <sup>1</sup>	Ambient Temp. <sup>2</sup> (°C)	Size <sup>3</sup> (mm)
ESP8684-WROOM-02C-N2	ESP8684H2	2 MB	-40 ~ 85	18.0 × 20.0 × 3.2
ESP8684-WROOM-02C-N4	ESP8684H4	4 MB		
ESP8684-WROOM-02UC-N2	ESP8684H2	2 MB	-40 ~ 85	18.0 × 14.3 × 3.2
ESP8684-WROOM-02UC-N4	ESP8684H4	4 MB		

<sup>1</sup> The modules use flash integrated in the chip's package.

<sup>2</sup> Ambient temperature specifies the recommended temperature range of the environment immediately outside the Espressif modules.

<sup>3</sup> For details, refer to Section [7.1 Physical Dimensions](#).

The ESP8684H2 chip and the ESP8684H4 chip fall into the same category, namely ESP8684 chip series. ESP8684 series of chips have a 32-bit RISC-V single-core processor.

They integrate a rich set of peripherals including UART, I2C, LED PWM controller, general DMA controller, temperature sensor, and SAR ADC.

**Note:**

For more information on ESP8684, please refer to [ESP8684 Series Datasheet](#).

## 1.3 Applications

- Smart Home
  - Light control
  - Smart button
  - Smart plug
  - Indoor positioning
- Industrial Automation
  - Industrial robot
  - Industrial field bus
- Consumer Electronics
  - Smart watch and bracelet
  - Over-the-top (OTT) devices
  - Logger toys and proximity sensing toys
- Health Care
  - Health monitor
  - Baby monitor
- Smart Agriculture

- Smart greenhouse
- Smart irrigation
- Agriculture robot
- Retail and Catering
- POS machines
- Service robot
- Generic Low-power IoT Sensor Hubs
- Generic Low-power IoT Data Loggers

# Contents

<b>1</b>	<b>Module Overview</b>	<b>2</b>
1.1	Features	2
1.2	Description	3
1.3	Applications	3
<b>2</b>	<b>Block Diagram</b>	<b>8</b>
<b>3</b>	<b>Pin Definitions</b>	<b>9</b>
3.1	Pin Layout	9
3.2	Pin Description	9
3.3	Strapping Pins	10
<b>4</b>	<b>Electrical Characteristics</b>	<b>13</b>
4.1	Absolute Maximum Ratings	13
4.2	Recommended Operating Conditions	13
4.3	DC Characteristics (3.3 V, 25 °C)	13
4.4	Current Consumption Characteristics	14
4.5	Wi-Fi Radio	15
4.5.1	Wi-Fi RF Standards	15
4.5.2	Wi-Fi RF Transmitter (TX) Specifications	15
4.5.3	Wi-Fi RF Receiver (RX) Specifications	16
4.6	Bluetooth LE Radio	17
4.6.1	Bluetooth LE RF Transmitter (TX) Specifications	17
4.6.2	Bluetooth LE RF Receiver (RX) Specifications	18
<b>5</b>	<b>Module Schematics</b>	<b>21</b>
<b>6</b>	<b>Peripheral Schematics</b>	<b>23</b>
<b>7</b>	<b>Physical Dimensions and PCB Land Pattern</b>	<b>24</b>
7.1	Physical Dimensions	24
7.2	Recommended PCB Land Pattern	25
7.3	Dimensions of External Antenna Connector	27
<b>8</b>	<b>Product Handling</b>	<b>28</b>
8.1	Storage Conditions	28
8.2	Electrostatic Discharge (ESD)	28
8.3	Reflow Profile	28
8.4	Ultrasonic Vibration	29
<b>9</b>	<b>Related Documentation and Resources</b>	<b>30</b>
	<b>Revision History</b>	<b>31</b>

## List of Tables

1	Ordering Information	3
2	Pin Definitions	9
3	Strapping Pins	11
4	Parameter Descriptions of Setup and Hold Times for the Strapping Pins	12
5	Absolute Maximum Ratings	13
6	Recommended Operating Conditions	13
7	DC Characteristics (3.3 V, 25 °C)	13
8	Current Consumption Depending on RF Modes	14
9	Current Consumption in Low-Power Modes	14
10	Current Consumption in Modem-sleep Mode	14
11	Wi-Fi RF Standards	15
12	TX Power with Spectral Mask and EVM Meeting 802.11 Standards	15
13	TX EVM Test	15
14	RX Sensitivity	16
15	Maximum RX Level	16
16	RX Adjacent Channel Rejection	16
17	Transmitter General Characteristics	17
18	Transmitter Characteristics - Bluetooth LE 1 Mbps	17
19	Transmitter Characteristics - Bluetooth LE 2 Mbps	17
20	Transmitter Characteristics - Bluetooth LE 125 Kbps	18
21	Transmitter Characteristics - Bluetooth LE 500 Kbps	18
22	Receiver Characteristics - Bluetooth LE 1 Mbps	18
23	Receiver Characteristics - Bluetooth LE 2 Mbps	19
24	Receiver Characteristics - Bluetooth LE 125 Kbps	20
25	Receiver Characteristics - Bluetooth LE 500 Kbps	20

## List of Figures

1	ESP8684-WROOM-02C Block Diagram	8
2	ESP8684-WROOM-02UC Block Diagram	8
3	Pin Layout (Top View)	9
4	Setup and Hold Times for the Strapping Pins	11
5	ESP8684-WROOM-02C Schematics	21
6	ESP8684-WROOM-02UC Schematics	22
7	Peripheral Schematics	23
8	ESP8684-WROOM-02C Physical Dimensions	24
9	ESP8684-WROOM-02UC Physical Dimensions	24
10	ESP8684-WROOM-02C Recommended PCB Land Pattern	25
11	ESP8684-WROOM-02UC Recommended PCB Land Pattern	26
12	Dimensions of External Antenna Connector	27
13	Reflow Profile	28

## 2 Block Diagram

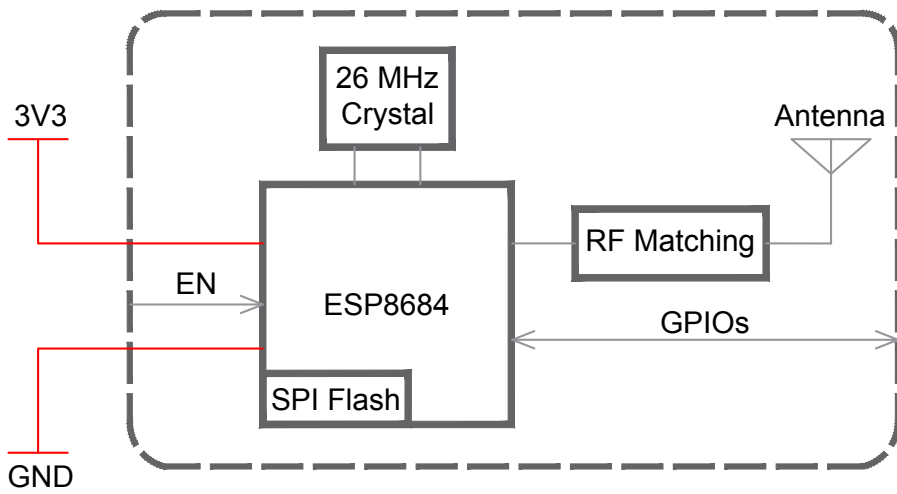

Figure 1: ESP8684-WROOM-02C Block Diagram

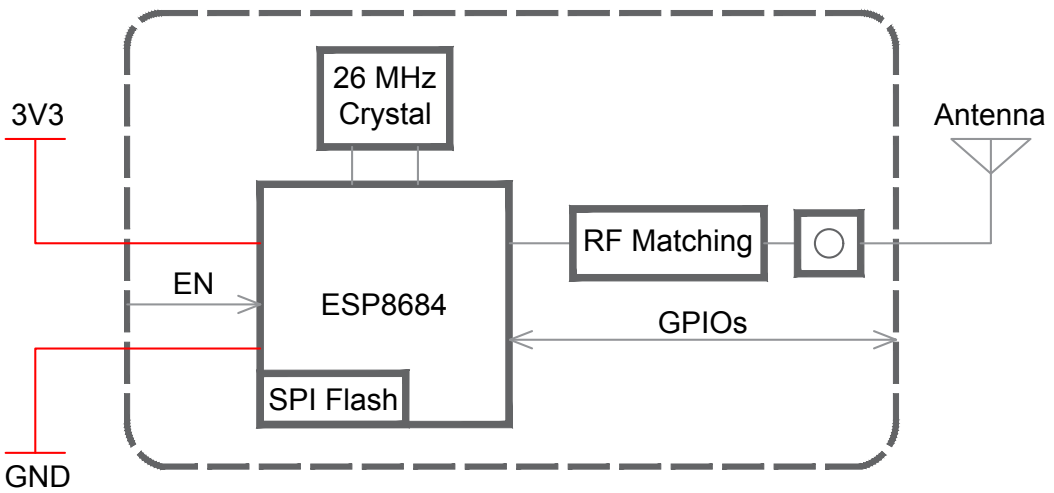

Figure 2: ESP8684-WROOM-02UC Block Diagram



## 3 Pin Definitions

### 3.1 Pin Layout

The pin diagram below shows the approximate location of pins on the module. For the actual diagram drawn to scale, please refer to Figure 7.1 *Physical Dimensions*.

The pin layout is applicable for ESP8684-WROOM-02UC and ESP8684-WROOM-02C, but the latter has no keep-out zone.

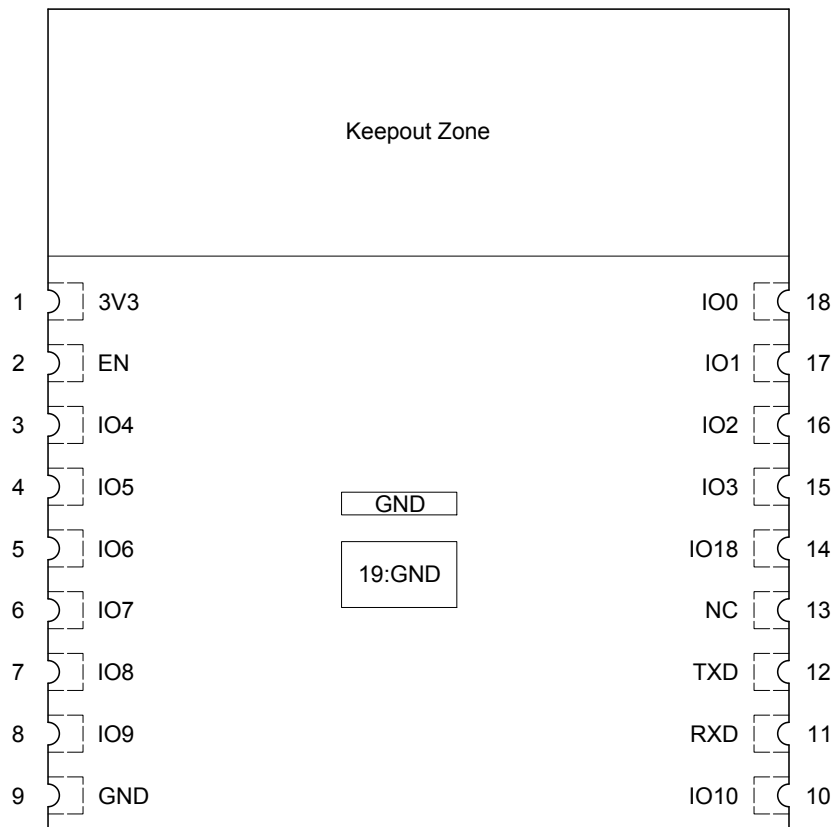

Figure 3: Pin Layout (Top View)

### 3.2 Pin Description

ESP8684-WROOM-02UC and ESP8684-WROOM-02C both have 19 pins, respectively. See pin definitions in Table 2.

For peripheral pin configurations, please refer to [ESP8684 Series Datasheet](#).

Table 2: Pin Definitions

Name	No.	Type <sup>1</sup>	Function
3V3	1	P	Power supply
EN	2	I	High: on, enables the chip. Low: off, the chip powers off. Note: Do not leave the CHIP_EN pin floating.

Cont'd on next page

Table 2 – cont'd from previous page

Name	No.	Type <sup>1</sup>	Function
IO4	3	I/O/T	GPIO4, ADC1_CH4, FSPIHD, MTMS
IO5	4	I/O/T	GPIO5, FSPIWP, MTDI
IO6	5	I/O/T	GPIO6, FSPICLK, MTCK
IO7	6	I/O/T	GPIO7, FSPID, MTDO
IO8	7	I/O/T	GPIO8 This pin is internally pulled high.
IO9	8	I/O/T	GPIO9
GND	9	P	Ground
IO10	10	I/O/T	GPIO10, FSPICS0
RXD	11	I/O/T	GPIO19, U0RXD
TXD	12	I/O/T	GPIO20, U0TXD
NC	13	—	NC
IO18	14	I/O/T	GPIO18
IO3	15	I/O/T	GPIO3, ADC1_CH3
IO2	16	I/O/T	GPIO2, ADC1_CH2, FSPIQ
IO1	17	I/O/T	GPIO1, ADC1_CH1
IO0	18	I/O/T	GPIO0, ADC1_CH0
GND	19	P	Ground

<sup>1</sup> P: power supply; I: input; O: output; T: high impedance.

**Note:**

IO0, IO1, IO3, IO5/MTDI pins have low-level glitches during chip power up. See details in the section General Purpose Input / Output Interface (GPIO) of [ESP8684 Series Datasheet](#).

### 3.3 Strapping Pins

**Note:**

The content below is excerpted from Section Strapping Pins in [ESP8684 Series Datasheet](#).

For the strapping pin mapping between the chip and modules, please refer to Chapter 5 [Module Schematics](#).

ESP8684 series has two strapping pins:

- GPIO8
- GPIO9

Software can read the values of GPIO8 and GPIO9 from GPIO\_STRAPPING field in GPIO\_STRAP\_REG register. For register description, please refer to Section GPIO Matrix Register Summary in [ESP8684 Technical Reference Manual](#).

During the chip's power-on reset, RTC watchdog reset, and brownout reset, the latches of the strapping pins sample the voltage level as strapping bits of "0" or "1", and hold these bits until the chip is powered down or shut down.

By default, GPIO9 is connected to the internal weak pull-up resistor. If GPIO9 is not connected or connected to an external high-impedance circuit, the latched bit value will be "1".

To change the strapping bit values, you can apply the external pull-down/pull-up resistances, or use the host MCU's GPIOs to control the voltage level of these pins when powering on ESP8684.

After reset, the strapping pins work as normal-function pins.

Table 3 lists detailed booting configurations of the strapping pins.

**Table 3: Strapping Pins**

Booting Mode <sup>1</sup>			
Pin	Default	SPI Boot	Download Boot
GPIO8	N/A	Don't care	1
GPIO9	Internal weak pull-up	1	0
Enabling/Disabling ROM Messages Print During Booting			
Pin	Default	Functionality	
GPIO8	N/A	When the value of eFuse field EFUSE_UART_PRINT_CONTROL is 0 (default), print is enabled and not controlled by GPIO8. 1, if GPIO8 is 0, print is enabled; if GPIO8 is 1, it is disabled. 2, if GPIO8 is 0, print is disabled; if GPIO8 is 1, it is enabled. 3, print is disabled and not controlled by GPIO8.	

<sup>1</sup> The strapping combination of GPIO8 = 0 and GPIO9 = 0 is invalid and will trigger unexpected behavior.

Figure 4 shows the setup and hold times for the strapping pins before and after the CHIP\_EN signal goes high. Details about the parameters are listed in Table 4.

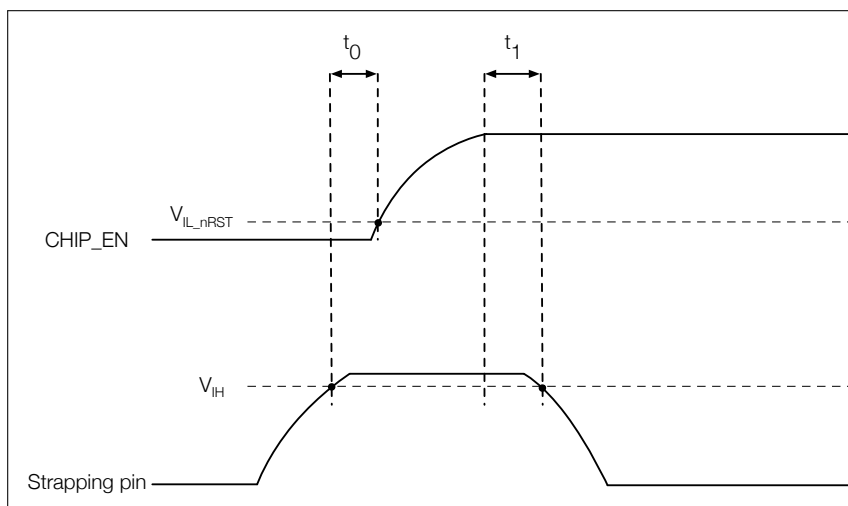

**Figure 4: Setup and Hold Times for the Strapping Pins**

**Table 4: Parameter Descriptions of Setup and Hold Times for the Strapping Pins**

<b>Parameter</b>	<b>Description</b>	<b>Min (ms)</b>
$t_0$	Setup time before CHIP_EN goes from low to high	0
$t_1$	Hold time after CHIP_EN goes high	3

## 4 Electrical Characteristics

The values presented in this section are preliminary and may change with the final release of this datasheet.

### 4.1 Absolute Maximum Ratings

Stresses beyond the absolute maximum ratings listed in the table below may cause permanent damage to the device. These are stress ratings only, and do not refer to the functional operation of the device. Exposure to absolute-maximum-rated conditions for extended periods may affect device reliability.

**Table 5: Absolute Maximum Ratings**

Symbol	Parameter	Min	Max	Unit
VDD33	Voltage applied to power supply pins per power domain	-0.3	3.6	V
T <sub>STORE</sub>	Storage temperature	-40	105	°C

### 4.2 Recommended Operating Conditions

**Table 6: Recommended Operating Conditions**

Symbol	Parameter	Min	Typ	Max	Unit
VDD33	Power supply voltage	3.0	3.3	3.6	V
I <sub>VDD</sub>	Current delivered by external power supply	0.5	—	—	A
T <sub>A</sub>	Operating ambient temperature	-40	—	85	°C

### 4.3 DC Characteristics (3.3 V, 25 °C)

**Table 7: DC Characteristics (3.3 V, 25 °C)**

Symbol	Parameter	Min	Typ	Max	Unit
C <sub>IN</sub>	Pin capacitance	—	2	—	pF
V <sub>IH</sub>	High-level input voltage	0.75 × VDD <sup>1</sup>	—	VDD <sup>1</sup> + 0.3	V
V <sub>IL</sub>	Low-level input voltage	-0.3	—	0.25 × VDD <sup>1</sup>	V
I <sub>IH</sub>	High-level input current	—	—	50	nA
I <sub>IL</sub>	Low-level input current	—	—	50	nA
V <sub>OH</sub> <sup>2</sup>	High-level output voltage	0.8 × VDD <sup>1</sup>	—	—	V
V <sub>OL</sub> <sup>2</sup>	Low-level output voltage	—	—	0.1 × VDD <sup>1</sup>	V
I <sub>OH</sub>	High-level source current (VDD <sup>1</sup> = 3.3 V, V <sub>OH</sub> ≥ 2.64 V, PAD_DRIVER = 3)	—	40	—	mA
I <sub>OL</sub>	Low-level sink current (VDD <sup>1</sup> = 3.3 V, V <sub>OL</sub> = 0.495 V, PAD_DRIVER = 3)	—	28	—	mA
R <sub>PU</sub>	Pull-up resistor	—	45	—	kΩ
R <sub>PD</sub>	Pull-down resistor	—	45	—	kΩ
V <sub>IH_nRST</sub>	Chip reset release voltage	0.75 × VDD <sup>1</sup>	—	VDD <sup>1</sup> + 0.3	V
V <sub>IL_nRST</sub>	Chip reset voltage	-0.3	—	0.25 × VDD <sup>1</sup>	V

<sup>1</sup> VDD is the I/O voltage for a particular power domain of pins.

<sup>2</sup> V<sub>OH</sub> and V<sub>OL</sub> are measured using high-impedance load.

## 4.4 Current Consumption Characteristics

Owing to the use of advanced power-management technologies, the module can switch between different power modes.

**Table 8: Current Consumption Depending on RF Modes**

Work mode	Description		Peak (mA)
Active (RF working)	TX	802.11b, 1 Mbps, @21 dBm	310
		802.11g, 54 Mbps, @19 dBm	260
		802.11n, HT20, MCS 7, @18 dBm	250
	RX	802.11b/g/n, HT20	65

<sup>1</sup> The current consumption measurements are taken with a 3.3 V supply at 25 °C of ambient temperature at the RF port. All transmitters' measurements are based on a 100% duty cycle.

<sup>2</sup> The current consumption figures in RX mode are for cases where the peripherals are disabled and the CPU idle.

**Table 9: Current Consumption in Low-Power Modes**

Work mode	Description	Typ	Unit
Light-sleep	—	140	μA
Deep-sleep	Only RTC timer is powered on	5	μA
Power off	CHIP_EN is set to low level, and the chip is powered off	1	μA

**Table 10: Current Consumption in Modem-sleep Mode**

Work mode	Frequency (MHz)	Description	Typ <sup>1</sup> (mA)	Typ <sup>2</sup> (mA)
Modem-sleep <sup>3</sup>	80	WFI (Wait-for-Interrupt)	9.4	10.3
		CPU run at full speed	12.1	13.0
	120	WFI (Wait-for-Interrupt)	10.7	11.5
		CPU run at full speed	14.7	15.6

<sup>1</sup> Current consumption when all peripheral clocks are **disabled**.

<sup>2</sup> Current consumption when all peripheral clocks are **enabled**. In practice, the current consumption might be different depending on which peripherals are enabled.

<sup>3</sup> In Modem-sleep mode, Wi-Fi is clock gated, and the current consumption might be higher when accessing flash. For a flash rated at 80 Mbit/s, in SPI 2-line mode the consumption is 10 mA.

## 4.5 Wi-Fi Radio

### 4.5.1 Wi-Fi RF Standards

**Table 11: Wi-Fi RF Standards**

Name	Description
Center frequency range of operating channel <sup>1</sup>	2412 ~ 2484 MHz
Wi-Fi wireless standard	IEEE 802.11b/g/n
Data rate (20 MHz)	11b: 1, 2, 5.5 and 11 Mbps 11g: 6, 9, 12, 18, 24, 36, 48, 54 Mbps 11n: MCS 0-7, 72.2 Mbps (Max)
Antenna type	PCB antenna

<sup>1</sup> Device should operate in the center frequency range allocated by regional regulatory authorities. Target center frequency range is configurable by software.

### 4.5.2 Wi-Fi RF Transmitter (TX) Specifications

Target TX power is configurable based on device or certification requirements. The default characteristics are provided in Table 12.

**Table 12: TX Power with Spectral Mask and EVM Meeting 802.11 Standards**

Rate	Min (dBm)	Typ (dBm)	Max (dBm)
802.11b, 1 Mbps	—	21	—
802.11b, 11 Mbps	—	21	—
802.11g, 6 Mbps	—	21	—
802.11g, 54 Mbps	—	19	—
802.11n, HT20, MCS 0	—	20	—
802.11n, HT20, MCS 7	—	18	—

**Table 13: TX EVM Test**

Rate	Min (dB)	Typ (dB)	SL <sup>1</sup> (dB)
802.11b, 1 Mbps, @21 dBm	—	-24	-10
802.11b, 11 Mbps, @21 dBm	—	-24	-10
802.11g, 6 Mbps, @21 dBm	—	-23	-5
802.11g, 54 Mbps, @19 dBm	—	-30	-25
802.11n, HT20, MCS 0, @20 dBm	—	-25	-5
802.11n, HT20, MCS 7, @18 dBm	—	-31	-27

<sup>1</sup> SL stands for standard limit value.

### 4.5.3 Wi-Fi RF Receiver (RX) Specifications

Table 14: RX Sensitivity

Rate	Min (dBm)	Typ (dBm)	Max (dBm)
802.11b, 1 Mbps	—	-99.0	—
802.11b, 2 Mbps	—	-96.5	—
802.11b, 5.5 Mbps	—	-94.0	—
802.11b, 11 Mbps	—	-90.0	—
802.11g, 6 Mbps	—	-94.0	—
802.11g, 9 Mbps	—	-92.0	—
802.11g, 12 Mbps	—	-91.0	—
802.11g, 18 Mbps	—	-89.0	—
802.11g, 24 Mbps	—	-86.0	—
802.11g, 36 Mbps	—	-83.0	—
802.11g, 48 Mbps	—	-78.5	—
802.11g, 54 Mbps	—	-77.0	—
802.11n, HT20, MCS 0	—	-92.5	—
802.11n, HT20, MCS 1	—	-90.5	—
802.11n, HT20, MCS 2	—	-87.5	—
802.11n, HT20, MCS 3	—	-84.5	—
802.11n, HT20, MCS 4	—	-81.5	—
802.11n, HT20, MCS 5	—	-77.5	—
802.11n, HT20, MCS 6	—	-75.5	—
802.11n, HT20, MCS 7	—	-74.0	—

Table 15: Maximum RX Level

Rate	Min (dBm)	Typ (dBm)	Max (dBm)
802.11b, 1 Mbps	—	5	—
802.11b, 11 Mbps	—	5	—
802.11g, 6 Mbps	—	5	—
802.11g, 54 Mbps	—	0	—
802.11n, HT20, MCS 0	—	5	—
802.11n, HT20, MCS 7	—	0	—

Table 16: RX Adjacent Channel Rejection

Rate	Min (dB)	Typ (dB)	Max (dB)
802.11b, 1 Mbps	—	35	—
802.11b, 11 Mbps	—	35	—

Cont'd on next page



Table 16 – cont'd from previous page

Rate	Min (dB)	Typ (dB)	Max (dB)
802.11g, 6 Mbps	—	31	—
802.11g, 54 Mbps	—	20	—
802.11n, HT20, MCS 0	—	16	—
802.11n, HT20, MCS 7	—	25	—

## 4.6 Bluetooth LE Radio

### 4.6.1 Bluetooth LE RF Transmitter (TX) Specifications

Table 17: Transmitter General Characteristics

Parameter	Min	Typ	Max	Unit
RF transmit power	—	3	—	dBm
Gain control step	—	3	—	dB
RF power control range	-24	—	20	dBm

Table 18: Transmitter Characteristics - Bluetooth LE 1 Mbps

Parameter	Description	Min	Typ	Max	Unit
In-band emissions	$F = F_0 \pm 2 \text{ MHz}$	—	-32.0	—	dBm
	$F = F_0 \pm 3 \text{ MHz}$	—	-38.0	—	dBm
	$F = F_0 \pm > 3 \text{ MHz}$	—	-41.0	—	dBm
Modulation characteristics	$\Delta f_{1\text{avg}}$	—	249.0	—	kHz
	$\Delta f_{2\text{max}}$	—	246.0	—	kHz
	$\Delta f_{2\text{avg}}/\Delta f_{1\text{avg}}$	—	1.1	—	—
Carrier frequency offset	$\text{Max }  f_n _{n=0, 1, 2, \dots, k}$	—	2.0	—	kHz
Carrier frequency drift	$\text{Max }  f_0 - f_n _{n=2, 3, 4, \dots, k}$	—	1.0	—	kHz
	$\text{Max }  f_0 - f_1 $	—	0.5	—	kHz
	$\text{Max }  f_n - f_{n-5} _{n=6, 7, 8, \dots, k}$	—	1.0	—	kHz

Table 19: Transmitter Characteristics - Bluetooth LE 2 Mbps

Parameter	Description	Min	Typ	Max	Unit
In-band emissions	$F = F_0 \pm 4 \text{ MHz}$	—	-40.0	—	dBm
	$F = F_0 \pm 5 \text{ MHz}$	—	-43.0	—	dBm
	$F = F_0 \pm > 5 \text{ MHz}$	—	-44.0	—	dBm
Modulation characteristics	$\Delta f_{1\text{avg}}$	—	498.0	—	kHz
	$\Delta f_{2\text{max}}$	—	589.0	—	kHz
	$\Delta f_{2\text{avg}}/\Delta f_{1\text{avg}}$	—	1.2	—	—
Carrier frequency offset	$\text{Max }  f_n _{n=0, 1, 2, \dots, k}$	—	1.0	—	kHz

Cont'd on next page

Table 19 – cont'd from previous page

Parameter	Description	Min	Typ	Max	Unit
Carrier frequency drift	Max $ f_0 - f_n _{n=2, 3, 4, \dots, k}$	—	3.0	—	kHz
	Max $ f_0 - f_1 $	—	2.4	—	kHz
	Max $ f_n - f_{n-5} _{n=6, 7, 8, \dots, k}$	—	1.2	—	kHz

Table 20: Transmitter Characteristics - Bluetooth LE 125 Kbps

Parameter	Description	Min	Typ	Max	Unit
In-band emissions	$F = F_0 \pm 2$ MHz	—	-32.0	—	dBm
	$F = F_0 \pm 3$ MHz	—	-38.0	—	dBm
	$F = F_0 \pm > 3$ MHz	—	-41.0	—	dBm
Modulation characteristics	$\Delta f_{1\text{avg}}$	—	248.0	—	kHz
	$\Delta f_{1\text{max}}$	—	224.0	—	kHz
Carrier frequency offset	Max $ f_n _{n=0, 1, 2, \dots, k}$	—	0.5	—	kHz
Carrier frequency drift	Max $ f_0 - f_n _{n=1, 2, 3, \dots, k}$	—	0.7	—	kHz
	Max $ f_0 - f_3 $	—	0.2	—	kHz
	Max $ f_n - f_{n-3} _{n=7, 8, 9, \dots, k}$	—	0.7	—	kHz

Table 21: Transmitter Characteristics - Bluetooth LE 500 Kbps

Parameter	Description	Min	Typ	Max	Unit
In-band emissions	$F = F_0 \pm 2$ MHz	—	-32.0	—	dBm
	$F = F_0 \pm 3$ MHz	—	-38.0	—	dBm
	$F = F_0 \pm > 3$ MHz	—	-41.0	—	dBm
Modulation characteristics	$\Delta f_{2\text{avg}}$	—	273.0	—	kHz
	$\Delta f_{2\text{max}}$	—	243.0	—	kHz
Carrier frequency offset	Max $ f_n _{n=0, 1, 2, \dots, k}$	—	0.5	—	kHz
Carrier frequency drift	Max $ f_0 - f_n _{n=1, 2, 3, \dots, k}$	—	0.7	—	kHz
	Max $ f_0 - f_3 $	—	0.7	—	kHz
	Max $ f_n - f_{n-3} _{n=7, 8, 9, \dots, k}$	—	0.2	—	kHz

#### 4.6.2 Bluetooth LE RF Receiver (RX) Specifications

Table 22: Receiver Characteristics - Bluetooth LE 1 Mbps

Parameter	Description	Min	Typ	Max	Unit
Sensitivity @30.8% PER	—	—	-98	—	dBm
Maximum received signal @30.8% PER	—	—	8	—	dBm
Co-channel C/I	—	—	8	—	dB

Cont'd on next page

Table 22 – cont'd from previous page

Parameter	Description	Min	Typ	Max	Unit
Adjacent channel selectivity C/I	$F = F_0 + 1 \text{ MHz}$	—	-1	—	dB
	$F = F_0 - 1 \text{ MHz}$	—	-3	—	dB
	$F = F_0 + 2 \text{ MHz}$	—	-26	—	dB
	$F = F_0 - 2 \text{ MHz}$	—	-28	—	dB
	$F \geq F_0 + 3 \text{ MHz}^{(1)}$	—	—	—	dB
	$F \leq F_0 - 3 \text{ MHz}$	—	-31	—	dB
Image frequency	—	—	-33	—	dB
Adjacent channel to image frequency	$F = F_{image} + 1 \text{ MHz}$	—	-32	—	dB
	$F = F_{image} - 1 \text{ MHz}$	—	-34	—	dB
Out-of-band blocking performance	30 MHz ~ 2000 MHz	—	-23	—	dBm
	2003 MHz ~ 2399 MHz	—	-30	—	dBm
	2484 MHz ~ 2997 MHz	—	-10	—	dBm
	3000 MHz ~ 12.75 GHz	—	-17	—	dBm
Intermodulation	—	—	-31	—	dBm

<sup>1</sup> Refer to the value of adjacent channel to image frequency when  $F = F_{image} - 1 \text{ MHz}$ .

Table 23: Receiver Characteristics - Bluetooth LE 2 Mbps

Parameter	Description	Min	Typ	Max	Unit
Sensitivity @30.8% PER	—	—	-95	—	dBm
Maximum received signal @30.8% PER	—	—	8	—	dBm
Co-channel C/I	$F = F_0 \text{ MHz}$	—	9	—	dB
Adjacent channel selectivity C/I	$F = F_0 + 2 \text{ MHz}$	—	-11	—	dB
	$F = F_0 - 2 \text{ MHz}$	—	-7	—	dB
	$F = F_0 + 4 \text{ MHz}^{(1)}$	—	—	—	dB
	$F = F_0 - 4 \text{ MHz}$	—	-30	—	dB
	$F \geq F_0 + 6 \text{ MHz}$	—	-35	—	dB
	$F \leq F_0 - 6 \text{ MHz}$	—	-29	—	dB
Image frequency	—	—	-35	—	dB
Adjacent channel to image frequency	$F = F_{image} + 2 \text{ MHz}$	—	-35	—	dB
	$F = F_{image} - 2 \text{ MHz}^{(2)}$	—	—	—	dB
Out-of-band blocking performance	30 MHz ~ 2000 MHz	—	-30	—	dBm
	2003 MHz ~ 2399 MHz	—	-34	—	dBm
	2484 MHz ~ 2997 MHz	—	-19	—	dBm
	3000 MHz ~ 12.75 GHz	—	-28	—	dBm
Intermodulation	—	—	-33	—	dBm

<sup>1</sup> Refer to the value of Image frequency.

<sup>2</sup> Refer to the value of Adjacent channel selectivity C/I when  $F = F_0 + 2 \text{ MHz}$ .

Table 24: Receiver Characteristics - Bluetooth LE 125 Kbps

Parameter	Description	Min	Typ	Max	Unit
Sensitivity @30.8% PER	—	—	-106	—	dBm
Maximum received signal @30.8% PER	—	—	8	—	dBm
Co-channel C/I	$F = F_0$ MHz	—	3	—	dB
Adjacent channel selectivity C/I	$F = F_0 + 1$ MHz	—	-7	—	dB
	$F = F_0 - 1$ MHz	—	-5	—	dB
	$F = F_0 + 2$ MHz	—	-35	—	dB
	$F = F_0 - 2$ MHz	—	-34	—	dB
	$F \geq F_0 + 3$ MHz <sup>(1)</sup>	—	—	—	dB
	$F \leq F_0 - 3$ MHz	—	-37	—	dB
Image frequency	—	—	-41	—	dB
Adjacent channel to image frequency	$F = F_{image} + 1$ MHz	—	-43	—	dB
	$F = F_{image} - 1$ MHz	—	-38	—	dB

<sup>1</sup> Refer to the value of Adjacent channel to image frequency when  $F = F_{image} - 1$  MHz.

Table 25: Receiver Characteristics - Bluetooth LE 500 Kbps

Parameter	Description	Min	Typ	Max	Unit
Sensitivity @30.8% PER	—	—	-102	—	dBm
Maximum received signal @30.8% PER	—	—	8	—	dBm
Co-channel C/I	$F = F_0$ MHz	—	4	—	dB
Adjacent channel selectivity C/I	$F = F_0 + 1$ MHz	—	-6	—	dB
	$F = F_0 - 1$ MHz	—	-5	—	dB
	$F = F_0 + 2$ MHz	—	-29	—	dB
	$F = F_0 - 2$ MHz	—	-32	—	dB
	$F \geq F_0 + 3$ MHz <sup>(1)</sup>	—	—	—	dB
	$F \leq F_0 - 3$ MHz	—	-36	—	dB
Image frequency	—	—	-34	—	dB
Adjacent channel to image frequency	$F = F_{image} + 1$ MHz	—	-37	—	dB
	$F = F_{image} - 1$ MHz	—	-31	—	dB

<sup>1</sup> Refer to the value of Adjacent channel to image frequency when  $F = F_{image} - 1$  MHz.

# 5 Module Schematics

This is the reference design of the module.

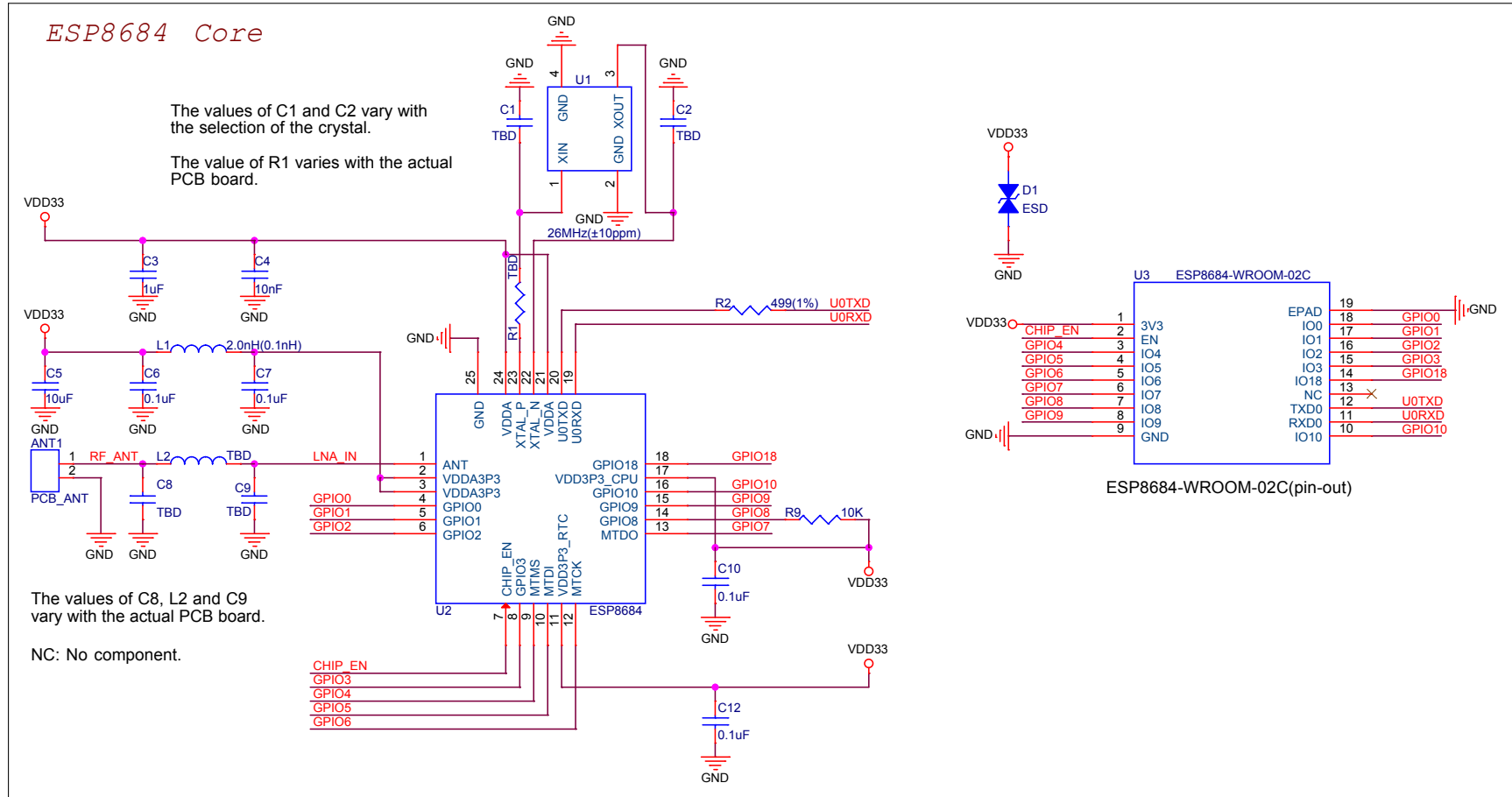

Figure 5: ESP8684-WROOM-02C Schematics

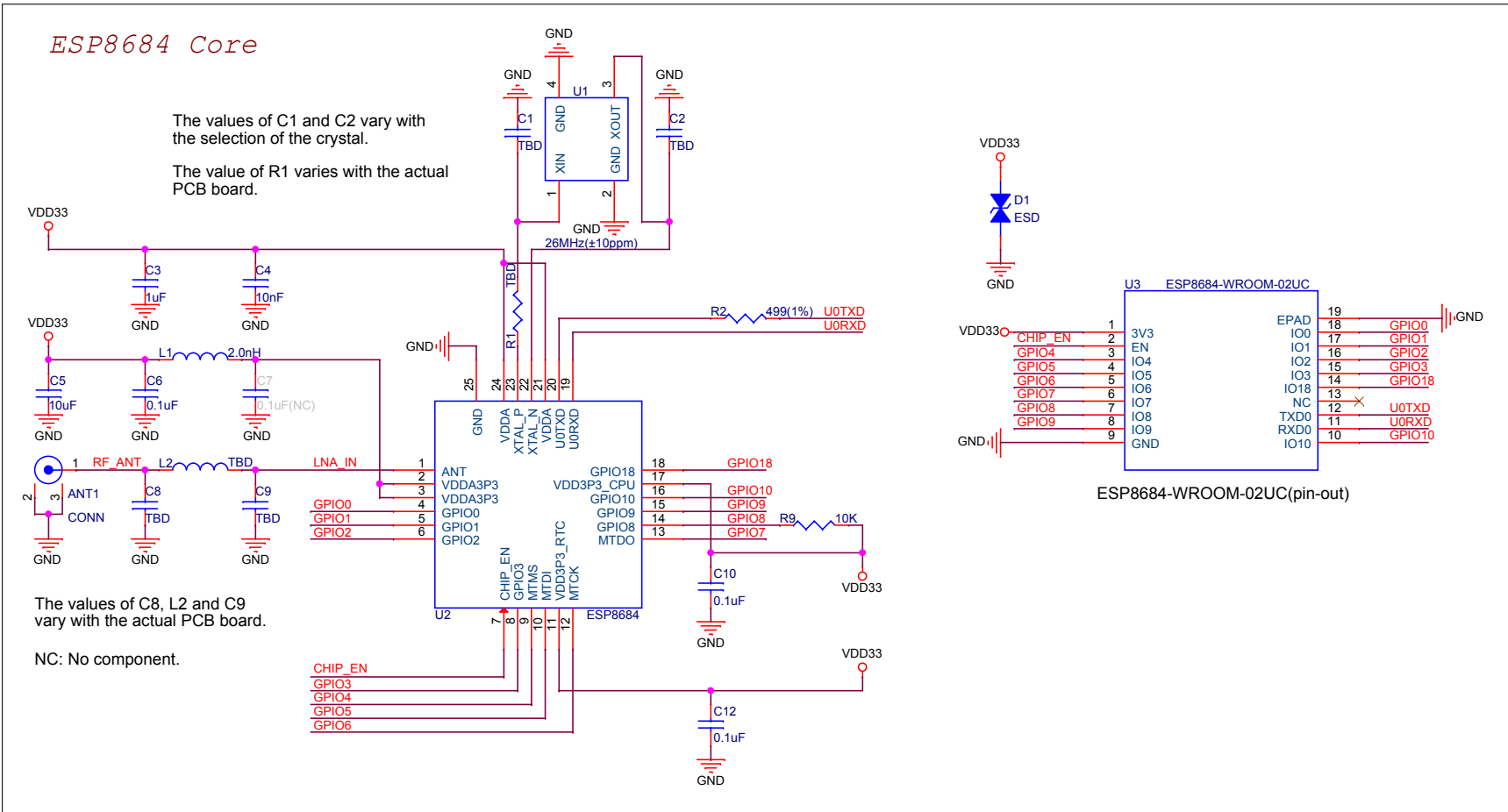

Figure 6: ESP8684-WROOM-02UC Schematics

## 6 Peripheral Schematics

This is the typical application circuit of the module connected with peripheral components (for example, power supply, antenna, reset button, JTAG interface, and UART interface).

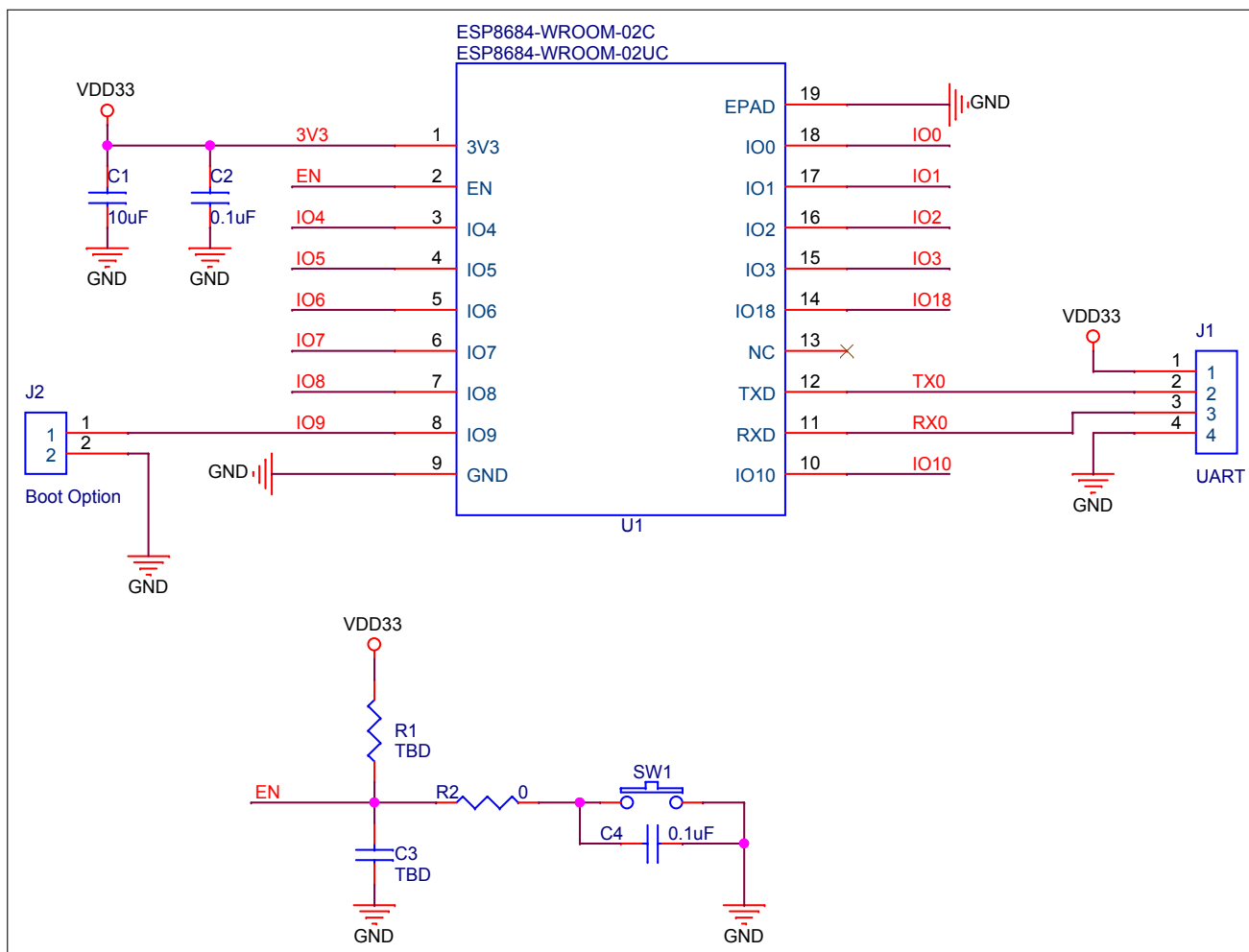

Figure 7: Peripheral Schematics

- Soldering the EPAD to the ground of the base board is not a must, however, it can optimize thermal performance. If you choose to solder it, please apply the correct amount of soldering paste. Too much soldering paste may increase the gap between the module and the baseboard. As a result, the adhesion between other pins and the baseboard may be poor.
- To ensure that the power supply to the ESP8684 chip is stable during power-up, it is advised to add an RC delay circuit at the EN pin. The recommended setting for the RC delay circuit is usually  $R = 10\text{ k}\Omega$  and  $C = 1\text{ }\mu\text{F}$ . However, specific parameters should be adjusted based on the power-up timing of the module and the power-up and reset sequence timing of the chip. For ESP8684's power-up and reset sequence timing diagram, please refer to Section *Power Scheme* in [ESP8684 Series Datasheet](#).

## 7 Physical Dimensions and PCB Land Pattern

### 7.1 Physical Dimensions

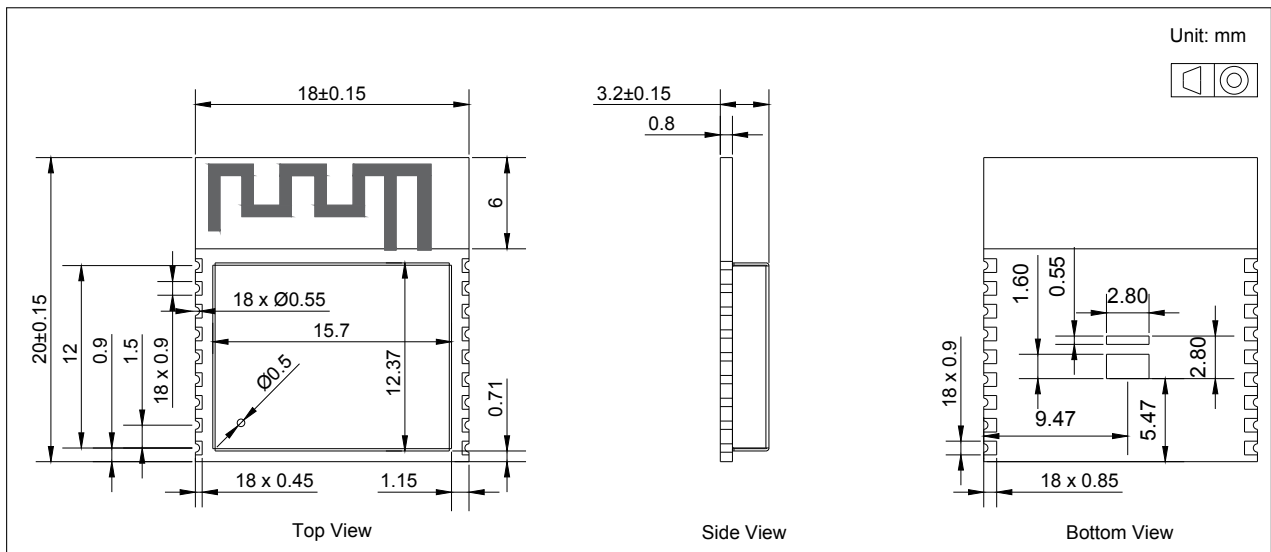

Figure 8: ESP8684-WROOM-02C Physical Dimensions

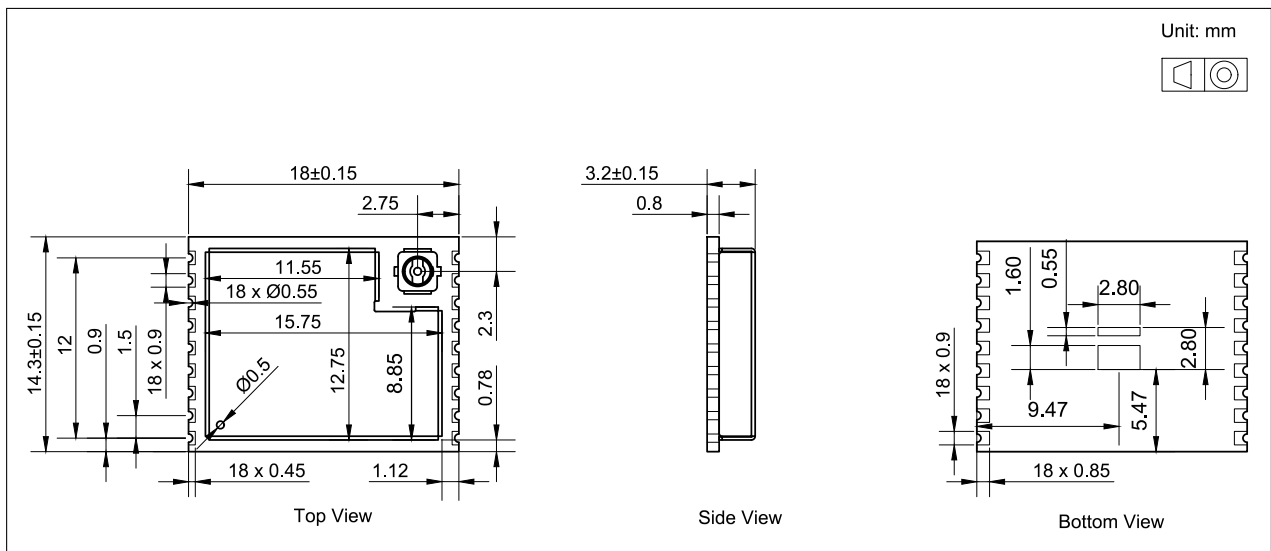

Figure 9: ESP8684-WROOM-02UC Physical Dimensions

**Note:**

For information about tape, reel, and product marking, please refer to [Espressif Module Package Information](#).



## 7.2 Recommended PCB Land Pattern

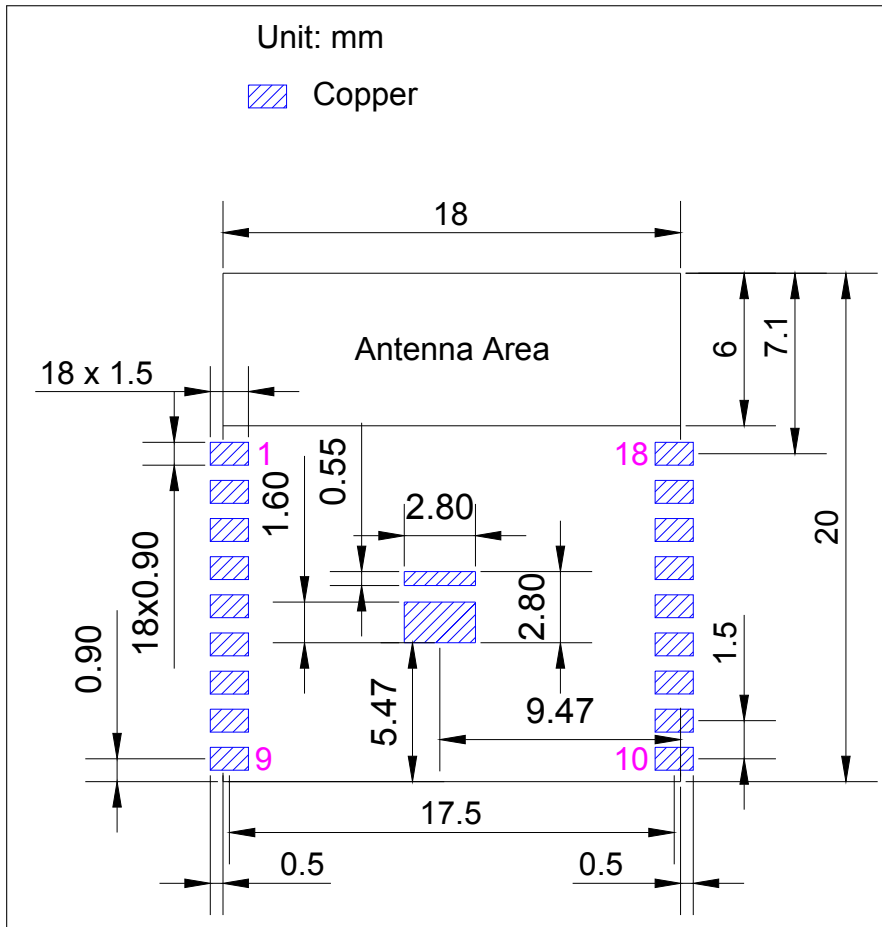

Figure 10: ESP8684-WROOM-02C Recommended PCB Land Pattern

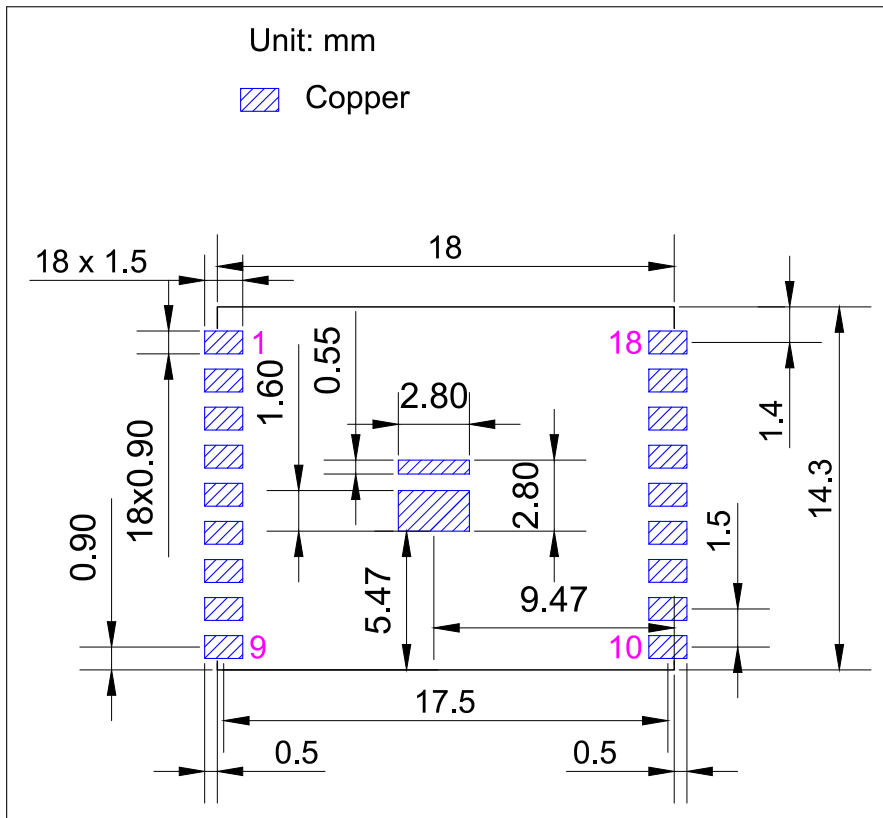

Figure 11: ESP8684-WROOM-02UC Recommended PCB Land Pattern

### 7.3 Dimensions of External Antenna Connector

ESP8684-WROOM-02UC uses the first generation external antenna connector as shown in Figure 12. This connector is compatible with the following connectors:

- U.FL Series connector from Hirose
- MHF I connector from I-PEX
- AMC connector from Amphenol

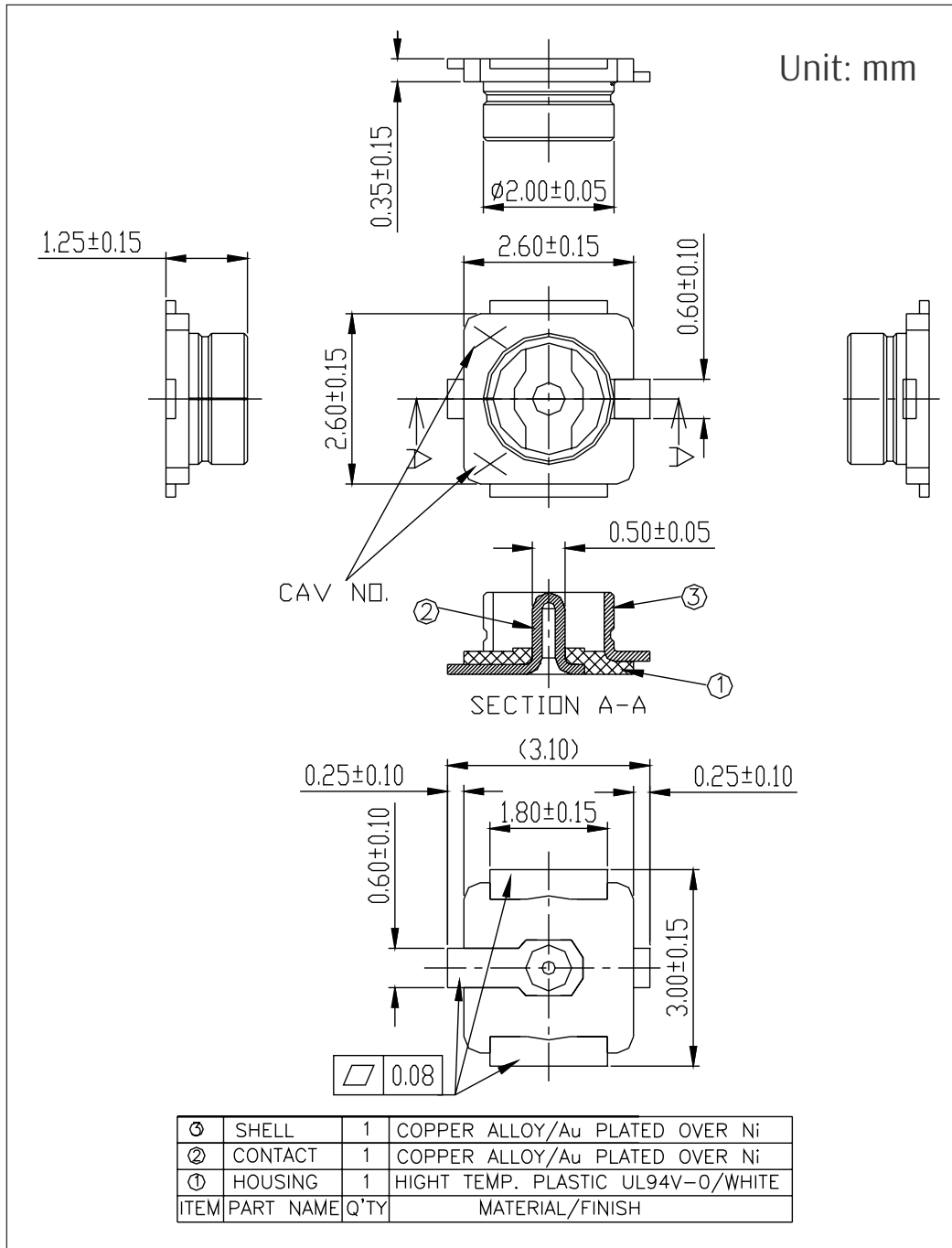

Figure 12: Dimensions of External Antenna Connector

## 8 Product Handling

### 8.1 Storage Conditions

The products sealed in moisture barrier bags (MBB) should be stored in a non-condensing atmospheric environment of  $< 40\text{ }^{\circ}\text{C}$  and 90%RH. The module is rated at the moisture sensitivity level (MSL) of 3.

After unpacking, the module must be soldered within 168 hours with the factory conditions  $25\pm 5\text{ }^{\circ}\text{C}$  and 60%RH. If the above conditions are not met, the module needs to be baked.

### 8.2 Electrostatic Discharge (ESD)

- Human body model (HBM):  $\pm 2000\text{ V}$
- Charged-device model (CDM):  $\pm 500\text{ V}$

### 8.3 Reflow Profile

Solder the module in a single reflow.

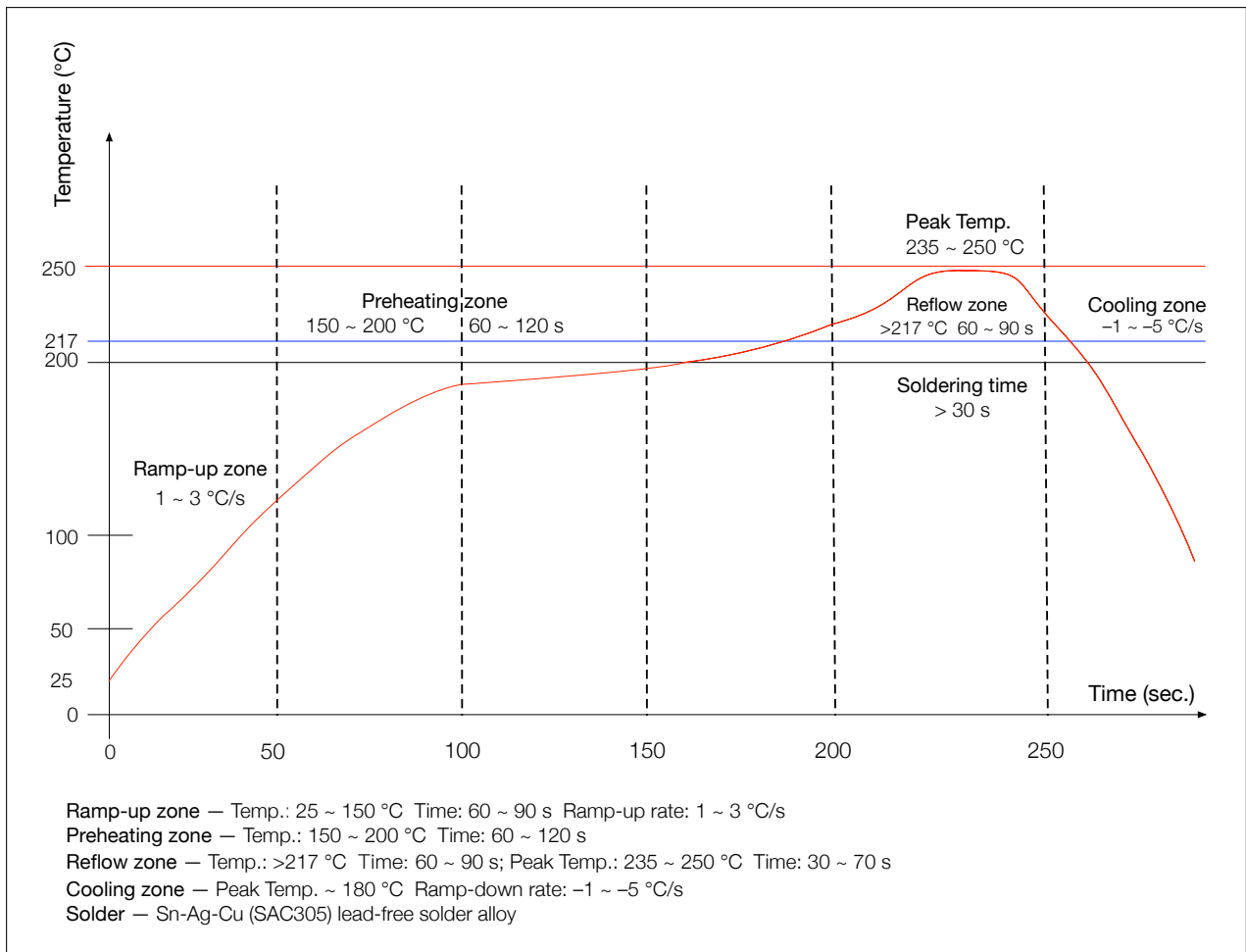

Figure 13: Reflow Profile

## 8.4 Ultrasonic Vibration

Avoid exposing Espressif modules to vibration from ultrasonic equipment, such as ultrasonic welders or ultrasonic cleaners. This vibration may induce resonance in the in-module crystal and lead to its malfunction or even failure. As a consequence, **the module may stop working or its performance may deteriorate.**

## 9 Related Documentation and Resources

### Related Documentation

- [ESP8684 Series Datasheet](#) – Specifications of the ESP8684 hardware.
- [ESP8684 Technical Reference Manual](#) – Detailed information on how to use the ESP8684 memory and peripherals.
- [ESP8684 Hardware Design Guidelines](#) – Guidelines on how to integrate the ESP8684 into your hardware product.
- *Certificates*  
<https://espressif.com/en/support/documents/certificates>
- *Documentation Updates and Update Notification Subscription*  
<https://espressif.com/en/support/download/documents>

### Developer Zone

- *ESP-IDF* and other development frameworks on GitHub.  
<https://github.com/espressif>
- *ESP32 BBS Forum* – Engineer-to-Engineer (E2E) Community for Espressif products where you can post questions, share knowledge, explore ideas, and help solve problems with fellow engineers.  
<https://esp32.com/>
- *The ESP Journal* – Best Practices, Articles, and Notes from Espressif folks.  
<https://blog.espressif.com/>
- See the tabs *SDKs and Demos, Apps, Tools, AT Firmware*.  
<https://espressif.com/en/support/download/sdk-demos>

### Products

- *ESP8684 Series SoCs* – Browse through all ESP8684 SoCs.  
<https://espressif.com/en/products/socs?id=ESP8684>
- *ESP8684 Series Modules* – Browse through all ESP8684-based modules.  
<https://espressif.com/en/products/modules?id=ESP8684>
- *ESP8684 Series DevKits* – Browse through all ESP8684-based devkits.  
<https://espressif.com/en/products/devkits?id=ESP8684>
- *ESP Product Selector* – Find an Espressif hardware product suitable for your needs by comparing or applying filters.  
<https://products.espressif.com/#/product-selector?language=en>

### Contact Us

- See the tabs *Sales Questions, Technical Enquiries, Circuit Schematic & PCB Design Review, Get Samples (Online stores), Become Our Supplier, Comments & Suggestions*.  
<https://espressif.com/en/contact-us/sales-questions>

## Revision History

Date	Version	Release notes
2023-02-21	v0.6	<ul style="list-style-type: none"><li>• Added information of ESP8684-WROOM-02UC</li><li>• Added a note to table <a href="#">2 Pin Definitions</a></li></ul>
2022-08-29	v0.5	Preliminary release



[www.espressif.com](http://www.espressif.com)

## Disclaimer and Copyright Notice

Information in this document, including URL references, is subject to change without notice.

ALL THIRD PARTY'S INFORMATION IN THIS DOCUMENT IS PROVIDED AS IS WITH NO WARRANTIES TO ITS AUTHENTICITY AND ACCURACY.

NO WARRANTY IS PROVIDED TO THIS DOCUMENT FOR ITS MERCHANTABILITY, NON-INFRINGEMENT, FITNESS FOR ANY PARTICULAR PURPOSE, NOR DOES ANY WARRANTY OTHERWISE ARISING OUT OF ANY PROPOSAL, SPECIFICATION OR SAMPLE.

All liability, including liability for infringement of any proprietary rights, relating to use of information in this document is disclaimed. No licenses express or implied, by estoppel or otherwise, to any intellectual property rights are granted herein.

The Wi-Fi Alliance Member logo is a trademark of the Wi-Fi Alliance. The Bluetooth logo is a registered trademark of Bluetooth SIG.

All trade names, trademarks and registered trademarks mentioned in this document are property of their respective owners, and are hereby acknowledged.

**Copyright © 2023 Espressif Systems (Shanghai) Co., Ltd. All rights reserved.**