

ERRATA

N° 10631AERRA

Dear customer,

With this Infineon Technologies AG errata note we would like to inform you about the following

Erratum of product datasheet update for BSS84P

Infineon Technologies AG

Postal address D-81726 München Internet www.infineon.com Headquarters Am Campeon 1-15, D-85579 Neubiberg Phone +49 (0)89 234-0

Chairman of the Supervisory Board Dr. Herbert Diess

Management Board Jochen Hanebeck (CEO), Alexander Gorski, Elke Reichart, Dr. Sven Schneider, Andreas Urschitz

Registered office Neubiberg Commercial register Amtsgericht München HRB 126492

ERRATA

N° 10631AERRA

- **Products affected** Please refer to attached affected product list
ERR_10631AERRA_[customer-no].pdf

- **Detailed change information**

Subject	Erratum of product datasheet update for BSS84P.	
Reason	Incorrect Crss (typ/max) value in the Datasheet.	
Description	<u>Old</u>	<u>New</u>
Dynamic Characteristics: Typ. value for Reverse transfer capacitance C_{rss}	- 2 pF	- 3 pF
Dynamic Characteristics: Max. value for Reverse transfer capacitance C_{rss}	- 3 pF	- 4 pF

- **Impact of change** **NO** physical change on device. Only change of datasheet.

- **Attachments**

ERR_10631ERRA_[customer-no].pdf 3_cip10631	affected product list product datasheet
---	--

- **Implementation date** Immediate

If you have any questions, please do not hesitate to contact your local sales office.

ERR 10631AERRA



Erratum of product datasheet update for BSS84P

Sales name	SP number	OPN	Package	Customer part number
BSS84P H6327	SP000929186	BSS84PH6327XTSA2	PG-SOT23-3	BSS84PH6327XTSA2

SIPMOS® Small-Signal-Transistor
Feature

- P-Channel
- Enhancement mode
- Logic Level
- Avalanche rated
- dv/dt rated
- Pb-free lead plating; RoHS compliant
- Qualified according to AEC Q101
- Halogen-free according to IEC61249-2-21

Product Summary

V_{DS}	-60	V
$R_{DS(on)}$	8	Ω
I_D	-0.17	A

PG-SOT-23

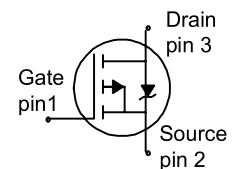
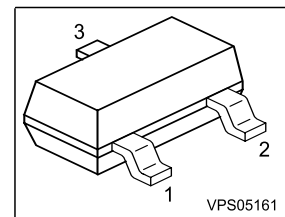

Type	Package	Tape and Reel	Marking
BSS84P	PG-SOT-23	H6327:3000pcs/r.	YBs
BSS84P	PG-SOT-23	H6433:10000pcs/r.	YBs

Maximum Ratings, at $T_A = 25\text{ }^\circ\text{C}$, unless otherwise specified

Parameter	Symbol	Value	Unit
Continuous drain current	I_D		A
$T_A=25\text{ }^\circ\text{C}$		-0.17	
$T_A=70\text{ }^\circ\text{C}$		-0.14	
Pulsed drain current	$I_{D\text{ puls}}$	-0.68	
$T_A=25\text{ }^\circ\text{C}$			
Avalanche energy, single pulse	E_{AS}	2.6	mJ
$I_D=-0.17\text{ A}$, $V_{DD}=-25\text{ V}$, $R_{GS}=25\Omega$			
Avalanche energy, periodic limited by T_{jmax}	E_{AR}	0.036	
Reverse diode dv/dt	dv/dt	-6	kV/ μs
$I_S=-0.17\text{ A}$, $V_{DS}=-48\text{ V}$, $di/dt=-200\text{ A}/\mu\text{s}$, $T_{jmax}=150\text{ }^\circ\text{C}$			
Gate source voltage	V_{GS}	± 20	V
Power dissipation	P_{tot}	0.36	W
$T_A=25\text{ }^\circ\text{C}$			
Operating and storage temperature	T_j, T_{stg}	-55... +150	$^\circ\text{C}$
IEC climatic category; DIN IEC 68-1		55/150/56	
ESD Class		Class 0	
JESD22-A114-HBM			

Thermal Characteristics

Parameter	Symbol	Values			Unit
		min.	typ.	max.	
Characteristics					
Thermal resistance, junction - soldering point (Pin 3)	R_{thJS}	-	-	200	K/W
SMD version, device on PCB: @ min. footprint	R_{thJA}	-	-	350	
@ 6 cm ² cooling area ¹⁾		-	-	300	

Electrical Characteristics, at $T_A = 25\text{ }^\circ\text{C}$, unless otherwise specified

Parameter	Symbol	Values			Unit
		min.	typ.	max.	
Static Characteristics					
Drain-source breakdown voltage $V_{GS}=0, I_D=-250\mu\text{A}$	$V_{(BR)DSS}$	-60	-	-	V
Gate threshold voltage, $V_{GS} = V_{DS}$ $I_D=-20\mu\text{A}$	$V_{GS(th)}$	-1	-1.5	-2	
Zero gate voltage drain current $V_{DS}=-60\text{V}, V_{GS}=0, T_A=25^\circ\text{C}$ $V_{DS}=-60\text{V}, V_{GS}=0, T_A=125^\circ\text{C}$	I_{DSS}	-	-0.1 -10	-1 -100	μA
Gate-source leakage current $V_{GS}=-20\text{V}, V_{DS}=0$	I_{GSS}	-	-10	-100	
Drain-source on-state resistance $V_{GS}=-4.5\text{V}, I_D=-0.14\text{A}$	$R_{DS(on)}$	-	8	12	Ω
Drain-source on-state resistance $V_{GS}=-10\text{V}, I_D=-0.17\text{A}$	$R_{DS(on)}$	-	5.8	8	

¹⁾Device on 40mm*40mm*1.5mm epoxy PCB FR4 with 6cm² (one layer, 70 μm thick) copper area for drain connection. PCB is vertical without blown air.

Electrical Characteristics, at $T_A = 25\text{ }^\circ\text{C}$, unless otherwise specified

Parameter	Symbol	Conditions	Values			Unit
			min.	typ.	max.	

Dynamic Characteristics

Transconductance	g_{fs}	$V_{DS} < 2 \cdot I_D \cdot R_{DS(on)max}$, $I_D = -0.14\text{A}$	0.065	0.13	-	S
Input capacitance	C_{iss}	$V_{GS} = 0$, $V_{DS} = -25\text{V}$, $f = 1\text{MHz}$	-	15	19	pF
Output capacitance	C_{oss}		-	6	8	
Reverse transfer capacitance	C_{rss}		-	3	4	
Turn-on delay time	$t_{d(on)}$	$V_{DD} = -30\text{V}$, $V_{GS} = -4.5\text{V}$, $I_D = -0.14\text{A}$, $R_G = 25\Omega$	-	6.7	10	ns
Rise time	t_r		-	16.2	24.3	
Turn-off delay time	$t_{d(off)}$		-	8.6	12.9	
Fall time	t_f		-	20.5	30.8	

Gate Charge Characteristics

Gate to source charge	Q_{gs}	$V_{DD} = -48\text{V}$, $I_D = -0.17\text{A}$	-	0.25	0.37	nC
Gate to drain charge	Q_{gd}		-	0.3	0.45	
Gate charge total	Q_g	$V_{DD} = -48\text{V}$, $I_D = -0.17\text{A}$, $V_{GS} = 0$ to -10V	-	1	1.5	
Gate plateau voltage	$V_{(plateau)}$	$V_{DD} = -48\text{V}$, $I_D = -0.17\text{A}$	-	-3.42	-	V

Reverse Diode

Inverse diode continuous forward current	I_S	$T_A = 25\text{ }^\circ\text{C}$	-	-	-0.17	A
Inv. diode direct current, pulsed	I_{SM}		-	-	-0.68	
Inverse diode forward voltage	V_{SD}	$V_{GS} = 0$, $I_F = -0.17\text{A}$	-	-0.93	-1.24	V
Reverse recovery time	t_{rr}	$V_R = -30\text{V}$, $I_F = I_S$, $di_F/dt = 100\text{A}/\mu\text{s}$	-	23	34	ns
Reverse recovery charge	Q_{rr}		-	10	15	

1 Power dissipation

$P_{tot} = f(T_A)$

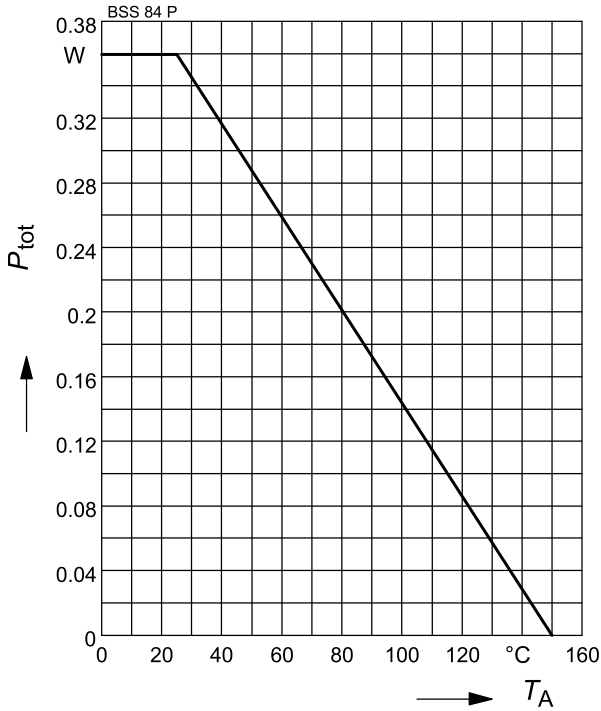

2 Drain current

$I_D = f(T_A)$

parameter: $V_{GS} \geq 10 \text{ V}$

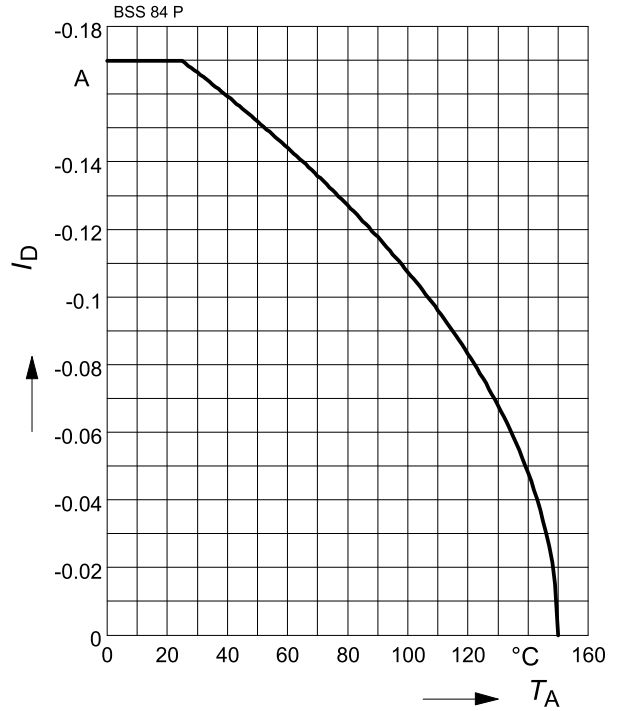

3 Safe operating area

$I_D = f(V_{DS})$

parameter : $D = 0$, $T_A = 25 \text{ °C}$

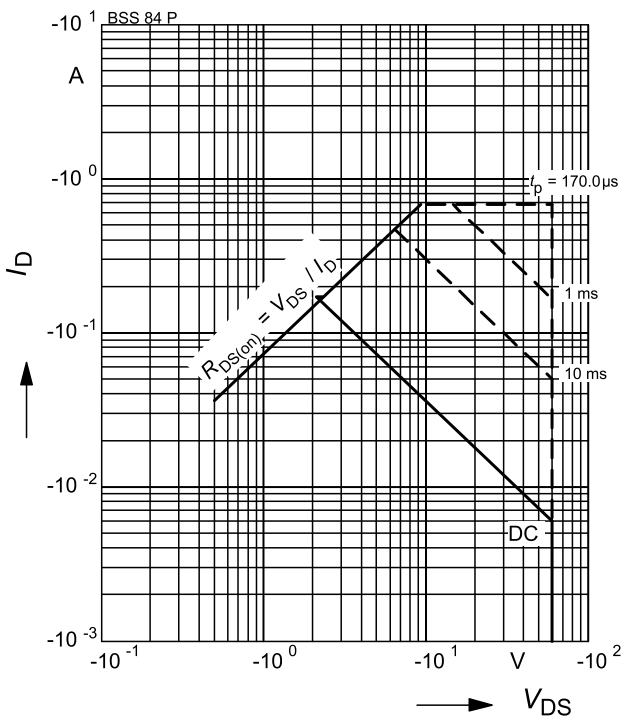

4 Transient thermal impedance

$Z_{thJA} = f(t_p)$

parameter : $D = t_p/T$

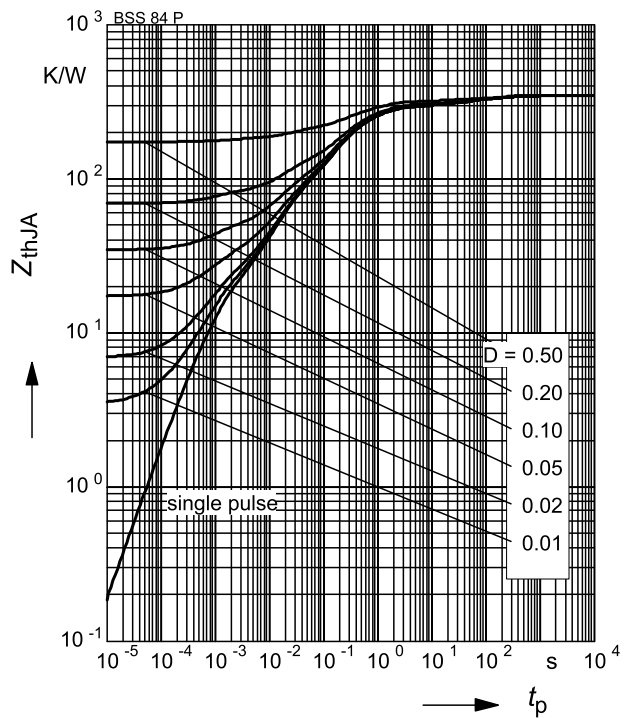

5 Typ. output characteristic

$$I_D = f(V_{DS})$$

parameter: $T_j = 25\text{ }^\circ\text{C}$

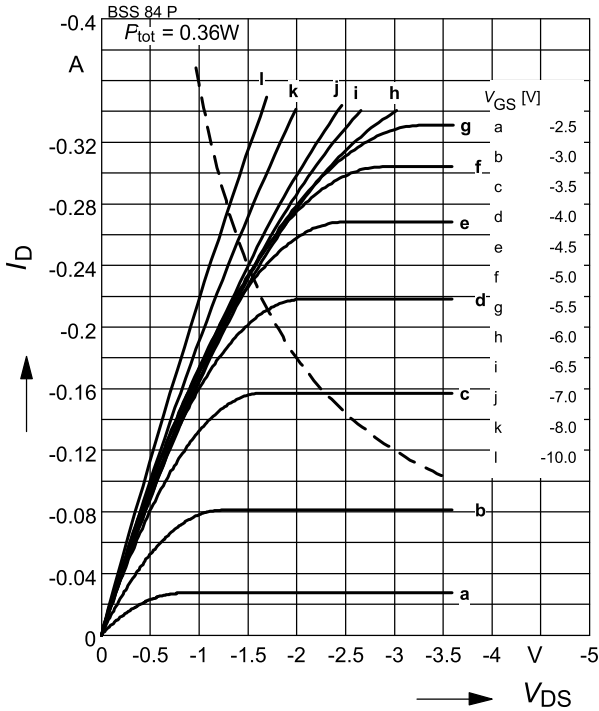

6 Typ. drain-source on resistance

$$R_{DS(on)} = f(I_D)$$

parameter: $V_{GS}; T_j = 25\text{ }^\circ\text{C}$

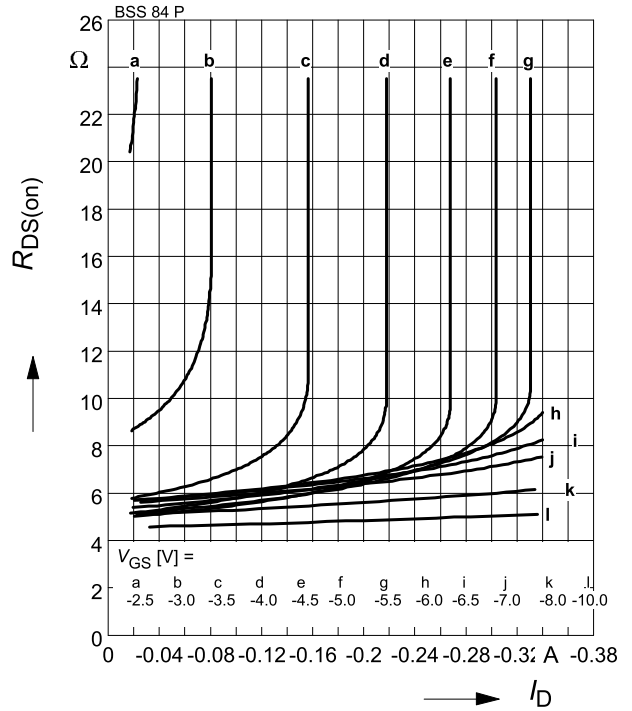

7 Typ. transfer characteristics

$$I_D = f(V_{GS}); |V_{DS}| \geq 2 \times |I_D| \times R_{DS(on)max}$$

parameter: $T_j = 25\text{ }^\circ\text{C}$

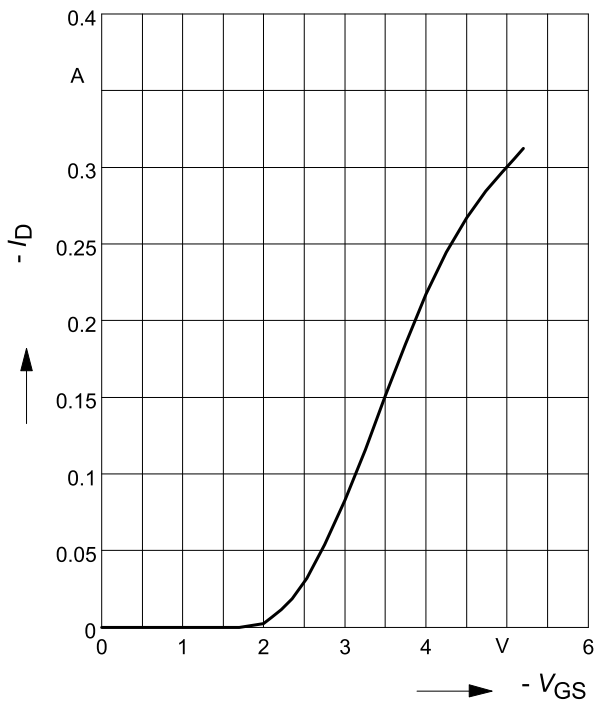

8 Typ. forward transconductance

$$g_{fs} = f(I_D)$$

parameter: $T_j = 25\text{ }^\circ\text{C}$

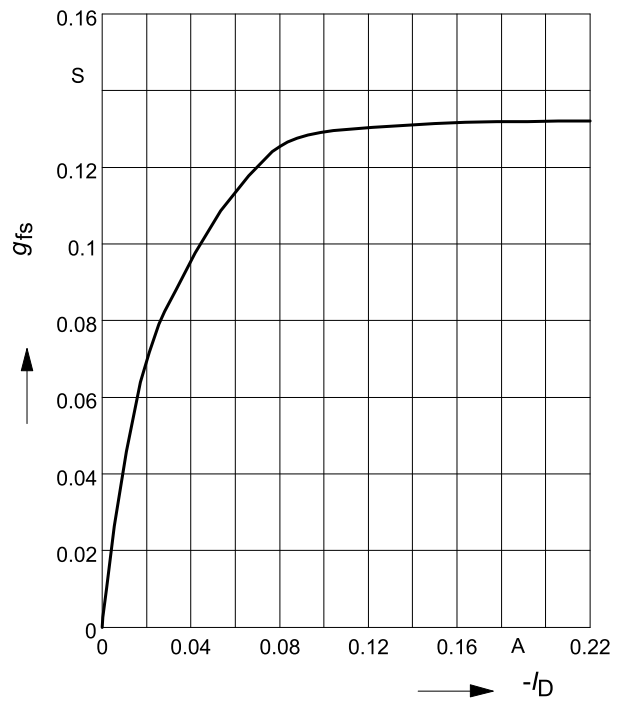

9 Drain-source on-state resistance

$$R_{DS(on)} = f(T_j)$$

parameter : $I_D = -0.17 \text{ A}$, $V_{GS} = -10 \text{ V}$

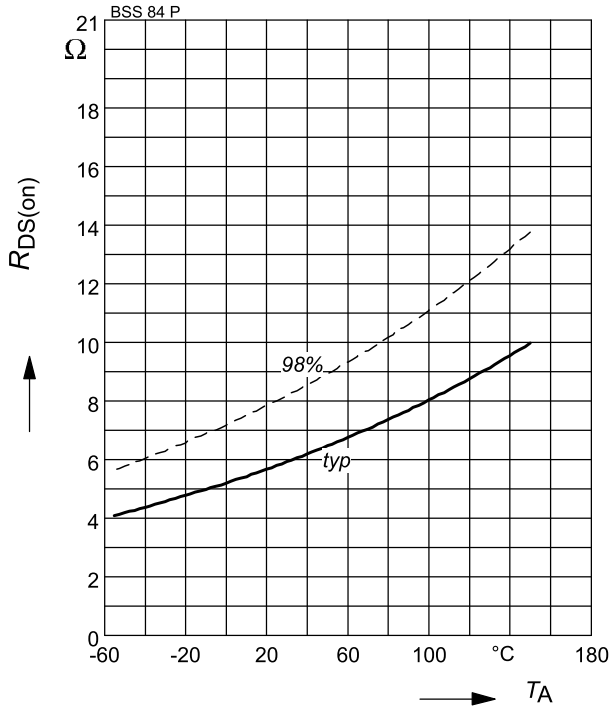

10 Typ. gate threshold voltage

$$V_{GS(th)} = f(T_j)$$

parameter: $V_{GS} = V_{DS}$

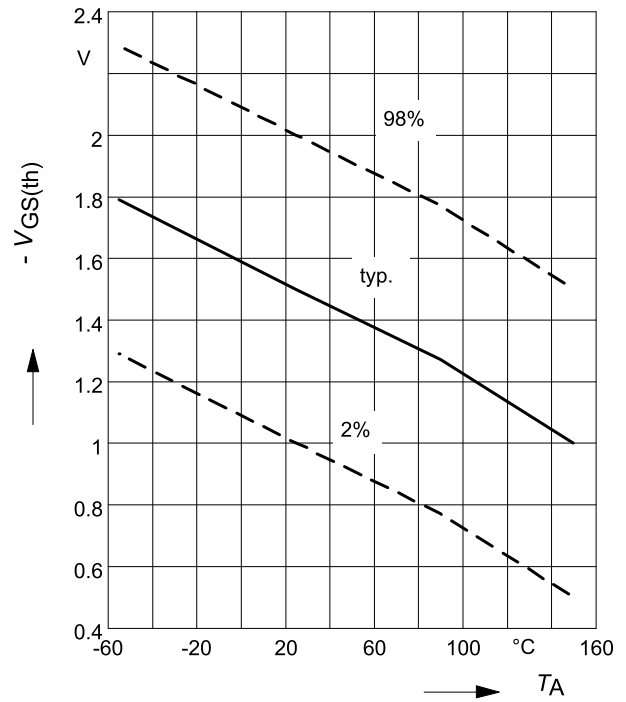

11 Typ. capacitances

$$C = f(V_{DS})$$

parameter: $V_{GS}=0$, $f=1 \text{ MHz}$

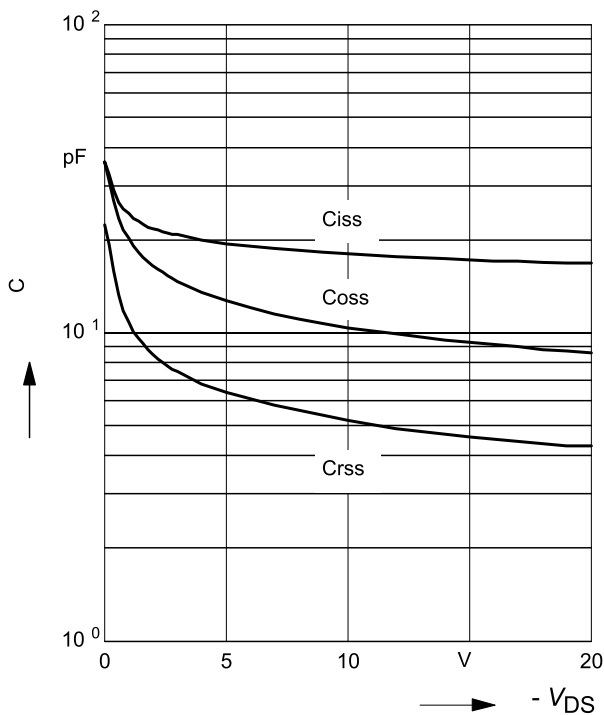

12 Forward character. of reverse diode

$$I_F = f(V_{SD})$$

parameter: T_j , $t_p = 80 \mu\text{s}$

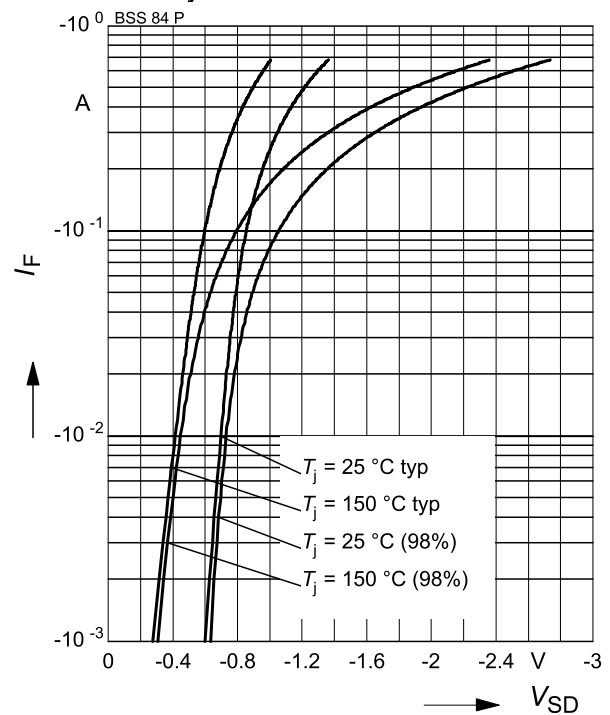

13 Typ. avalanche energy
 $E_{AS} = f(T_A)$, parameter:

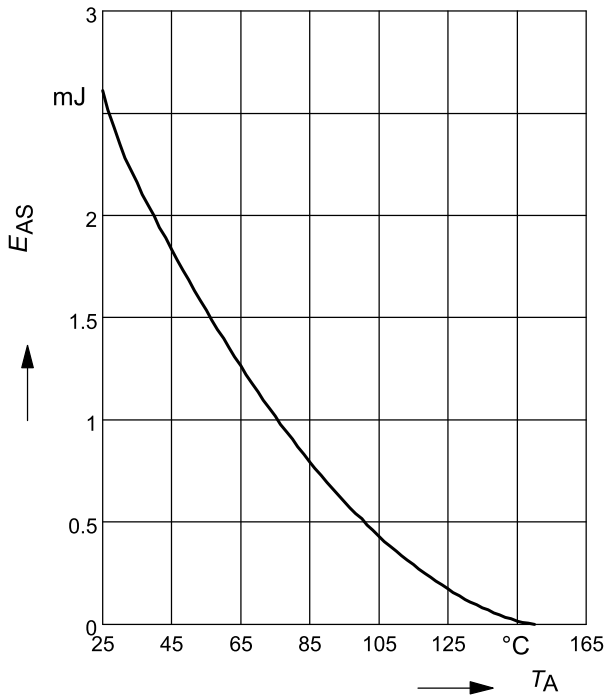
 $I_D = -0.17 \text{ A}$, $V_{DD} = -25 \text{ V}$, $R_{GS} = 25 \Omega$

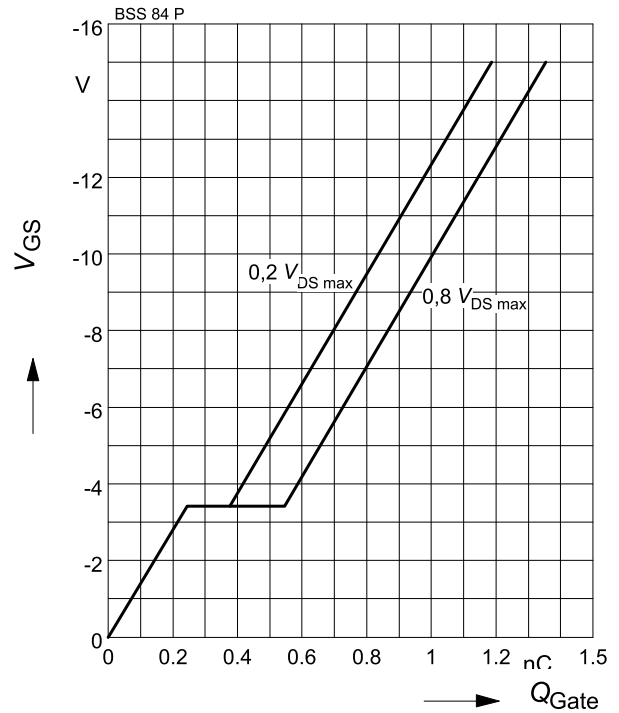
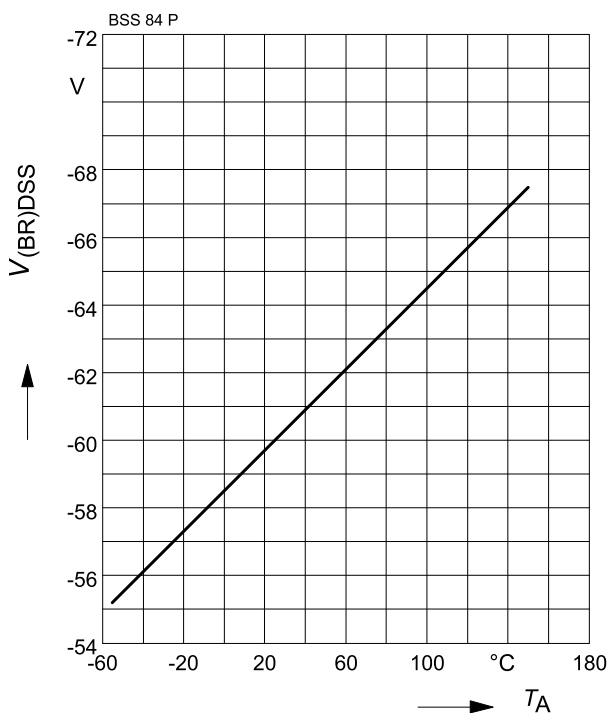
14 Typ. gate charge
 $V_{GS} = f(Q_{Gate})$

parameter: $I_D = -0.17 \text{ A}$ pulsed; $T_j = 25 \text{ °C}$

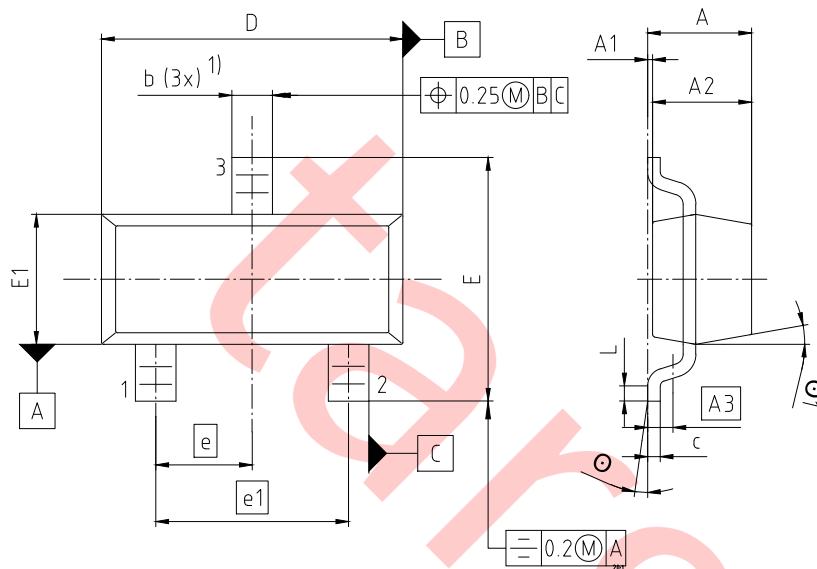
15 Drain-source breakdown voltage
 $V_{(BR)DSS} = f(T_A)$

5 Package outlines

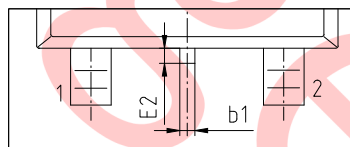

PACKAGE - GROUP NUMBER:		PG-SOT23-3-U01	
DIMENSIONS	MILLIMETERS		
	MIN.	MAX.	
A	0.89	1.22	
A1	---	0.10	
A2	0.88	1.02	
A3	0.25		
b	0.35	0.50	
b1	0.10	0.25	
c	0.05	0.25	
D	2.80	3.00	
E	2.25	2.55	
E1	1.20	1.40	
E2	0.15	0.25	
e	0.95		
e1	1.90		
L	0.15	---	
O	0°	8°	
O1	10°	14°	
N	3		

OPTIONAL CONTOUR



NOTES:

1) LEAD WIDTH CAN BE 0.6 MM MAX. IN DAMBAR AREA

DIMENSIONS DO NOT INCLUDE MOLD FLASH, PROTRUSION OR GATE BURRS

Figure 1 Outline PG-SOT23-3mm

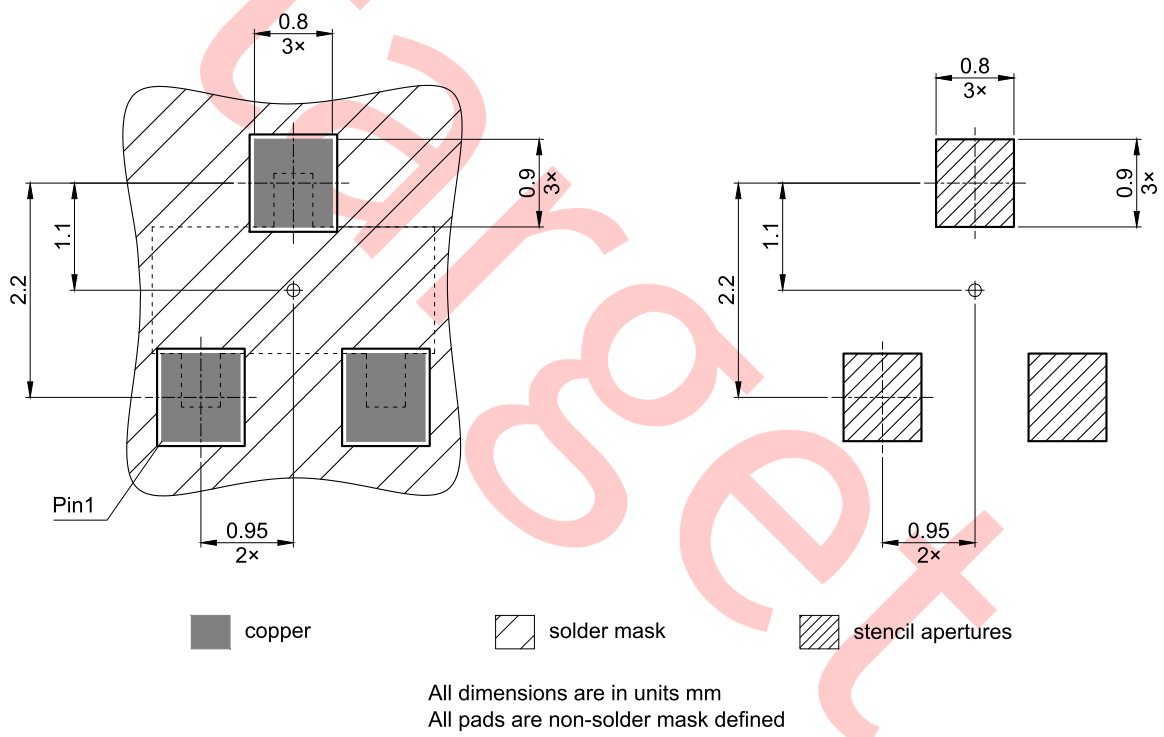
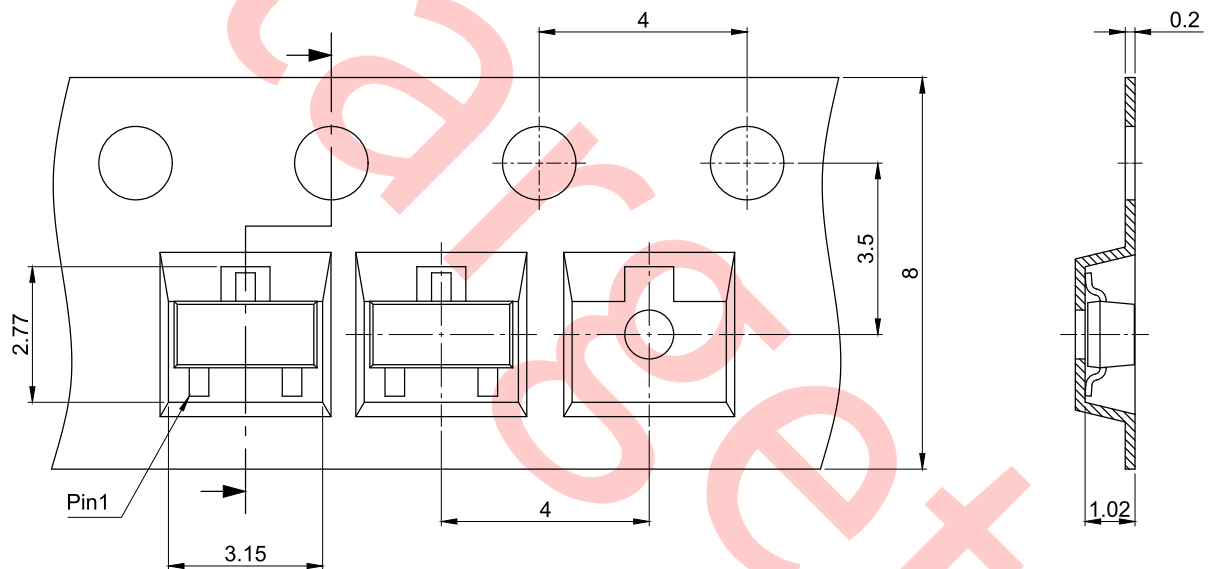

Figure 2 Footprint drawing PG-SOT23-3mm



All dimensions are in units mm
The drawing is in compliance with ISO 128-30, Projection Method 1 []

Figure 3 Packaging variant PG-SOT23-3mm

Revision history

BSS84P

Revision 2026-01-29, Rev. 1.0

Previous revisions

Revision	Date	Subjects (major changes since last revision)
1.0	2026-01-29	Update Crss

Trademarks

All referenced product or service names and trademarks are the property of their respective owners.

Published by Infineon Technologies AG, Am Campeon 1-15, 85579 Neubiberg, Germany
Copyright (c) 2026 Infineon Technologies AG and its affiliates. All Rights Reserved.

Important notice

Products which may also include samples and may be comprised of hardware or software or both ("Product(s)") are sold or provided and delivered by Infineon Technologies AG and its affiliates ("Infineon") subject to the terms and conditions of the frame supply contract or other written agreement(s) executed by a customer and Infineon or, in the absence of the foregoing, the applicable Sales Conditions of Infineon. General terms and conditions of a customer or deviations from applicable Sales Conditions of Infineon shall only be binding for Infineon if and to the extent Infineon has given its express written consent.

For the avoidance of doubt, Infineon disclaims all warranties of non-infringement of third-party rights and implied warranties such as warranties of fitness for a specific use/purpose or merchantability.

Infineon shall not be responsible for any information with respect to samples, the application or customer's specific use of any Product or for any examples or typical values given in this document.

The data contained in this document is exclusively intended for technically qualified and skilled customer representatives. It is the responsibility of the customer to evaluate the suitability of the Product for the intended application and the customer's specific use and to verify all relevant technical data contained in this document in the intended application and the customer's specific use. The customer is responsible for properly designing, programming, and testing the functionality and safety of the intended application, as well as complying with any legal requirements related to its use.

Unless otherwise explicitly approved by Infineon, Products may not be used in any application where a failure of the Products or any consequences of the use thereof can reasonably be expected to result in personal injury. However, the foregoing shall not prevent the customer from using any Product in such fields of use that Infineon has explicitly designed and sold it for, provided that the overall responsibility for the application lies with the customer.

Infineon expressly reserves the right to use its content for commercial text and data mining (TDM) according to applicable laws, e.g. Section 44b of the German Copyright Act (UrhG).

If the Product includes security features: Because no computing device can be absolutely secure, and despite security measures implemented in the Product, Infineon does not guarantee that the Product will be free from intrusion, data theft or loss, or other breaches ("Security Breaches"), and Infineon shall have no liability arising out of any Security Breaches.

If this document includes or references software:

The software is owned by Infineon under the intellectual property laws and treaties of the United States, Germany, and other countries worldwide. All rights reserved. Therefore, you may use the software only as provided in the software license agreement accompanying the software. If no software license agreement applies, Infineon hereby grants you a personal, non-exclusive, non-transferable license (without the right to sublicense) under its intellectual property rights in the software (a) for software provided in source code form, to modify and reproduce the software solely for use with Infineon hardware products, only internally within your organization, and (b) to distribute the software in binary code form externally to end users, solely for use on Infineon hardware products. Any other use, reproduction, modification, translation, or compilation of the software is prohibited.

For further information on the Product, technology, delivery terms and conditions, and prices, please contact your nearest Infineon office or visit <https://www.infineon.com>.