

## N-Channel Power MOSFET

### FEATURES

- Latest super-junction technology
- Low gate charge capacitance
- High gate noise immunity
- RoHS compliant
- Halogen-free

### APPLICATIONS

- Switching applications
- Industrial

KEY PERFORMANCE PARAMETERS		
PARAMETER	VALUE	UNIT
$V_{DS} @ T_{j,max}$	650	V
$R_{DS(on)} (max)$	285	m $\Omega$
$Q_{g,typ}$	22	nC



ITO-220TL

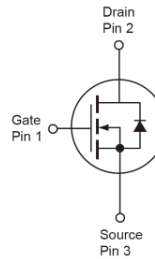
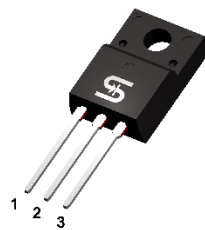

ABSOLUTE MAXIMUM RATINGS ( $T_A = 25^\circ\text{C}$ unless otherwise noted)			
PARAMETER	SYMBOL	LIMIT	UNIT
Drain-Source Voltage	$V_{DS}$	600	V
Gate-Source Voltage	$V_{GS}$	$\pm 30$	V
Continuous Drain Current	$I_D$	9.5	A
Pulsed Drain Current (Note 1)	$I_{DM}$	38	A
Total Power Dissipation @ $T_C = 25^\circ\text{C}$	$P_D$	56	W
Single Pulse Avalanche Energy (Note 2)	$E_{AS}$	221	mJ
Single Pulse Avalanche Current (Note 2)	$I_{AS}$	3	A
Operating Junction and Storage Temperature Range	$T_J, T_{STG}$	- 55 to +150	$^\circ\text{C}$

THERMAL PERFORMANCE			
PARAMETER	SYMBOL	LIMIT	UNIT
Junction to Case Thermal Resistance	$R_{\theta JC}$	2.2	$^\circ\text{C/W}$
Junction to Ambient Thermal Resistance (Note 3)	$R_{\theta JA}$	65	$^\circ\text{C/W}$

#### Notes:

1. Pulse Width  $\leq 100\mu\text{s}$ .
2.  $L = 50\text{mH}$ ,  $R_G = 25\Omega$ , Starting  $T_J = 25^\circ\text{C}$ .
3.  $R_{\theta JA}$  is the sum of the junction-to-case and case-to-ambient thermal resistances.  $R_{\theta JA}$  is guaranteed by design while  $R_{\theta JC}$  is determined by the user's board design.

**ELECTRICAL SPECIFICATIONS** ( $T_A = 25^\circ\text{C}$  unless otherwise noted)

PARAMETER	CONDITIONS	SYMBOL	MIN	TYP	MAX	UNIT
<b>Static</b> (Note 4)						
Drain-Source Breakdown Voltage	$V_{GS} = 0V, I_D = 1mA$	$BV_{DSS}$	600	--	--	V
Gate Threshold Voltage	$V_{DS} = V_{GS}, I_D = 1.4mA$	$V_{GS(TH)}$	4	4.8	6	V
Gate Body Leakage	$V_{GS} = \pm 30V, V_{DS} = 0V$	$I_{GSS}$	--	--	$\pm 100$	nA
Zero Gate Voltage Drain Current	$V_{DS} = 600V, V_{GS} = 0V$	$I_{DSS}$	--	--	100	$\mu A$
Drain-Source On-State Resistance	$V_{GS} = 10V, I_D = 3.2A$	$R_{DS(on)}$	--	239	285	m $\Omega$
	$V_{GS} = 12V, I_D = 3.2A$		--	228	274	
<b>Dynamic</b> (Note 5)						
Total Gate Charge	$V_{DS} = 480V, I_D = 9.5A,$ $V_{GS} = 10V$	$Q_g$	--	22	--	nC
Gate-Source Charge		$Q_{gs}$	--	7.5	--	
Gate-Drain Charge		$Q_{gd}$	--	12	--	
Input Capacitance	$V_{DS} = 300V, V_{GS} = 0V,$ $f = 100kHz$	$C_{iss}$	--	894	--	pF
Output Capacitance		$C_{oss}$	--	30	--	
Reverse Transfer Capacitance		$C_{rss}$	--	7	--	
Gate Resistance	$f = 1.0MHz$	$R_g$	--	1.2	--	$\Omega$
<b>Switching</b> (Note 6)						
Turn-On Delay Time	$V_{DD} = 300V, R_G = 3.3\Omega,$ $I_D = 9.5A, V_{GS} = 10V$	$t_{d(on)}$	--	23	--	ns
Turn-On Rise Time		$t_r$	--	22	--	
Turn-Off Delay Time		$t_{d(off)}$	--	45	--	
Turn-Off Fall Time		$t_f$	--	4.2	--	
<b>Source-Drain Diode</b>						
Forward Voltage (Note 4)	$I_S = 3.2A, V_{GS} = 0V$	$V_{SD}$	--	0.8	1.5	V
Reverse Recovery Time	$I_S = 4.8A$	$t_{rr}$	--	257	--	ns
Reverse Recovery Charge	$di_f/dt = 100A/\mu s$	$Q_{rr}$	--	2.8	--	$\mu C$

**Notes:**

- Pulse test: Pulse Width  $\leq 300\mu s$ , duty cycle  $\leq 2\%$ .
- Defined by design. Not subject to production test.
- Switching time is essentially independent of operating temperature.

**ORDERING INFORMATION**

ORDERING CODE	PACKAGE	PACKING
TSM60NE285CIT C0G	ITO-220TL	50pcs / Tube

**CHARACTERISTICS CURVES**

( $T_c = 25^\circ\text{C}$  unless otherwise noted)

**Output Characteristics**

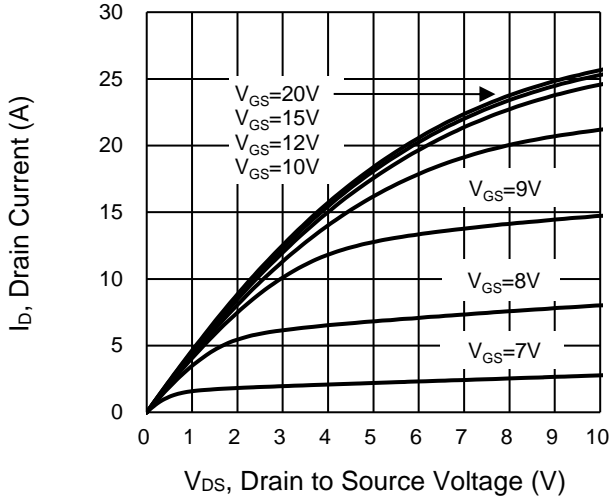

**Transfer Characteristics**

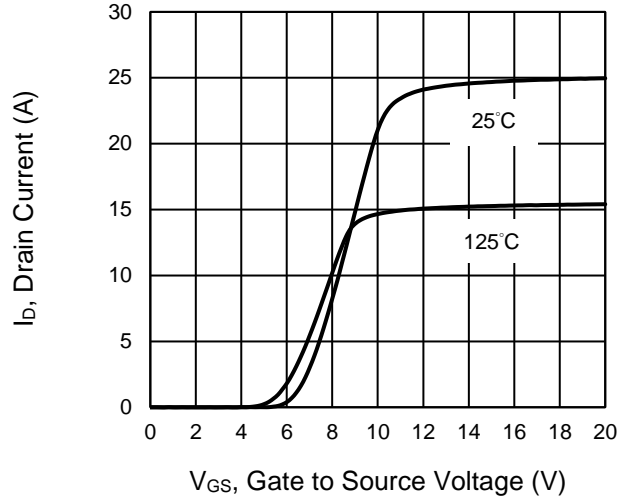

**On-Resistance vs. Drain Current**

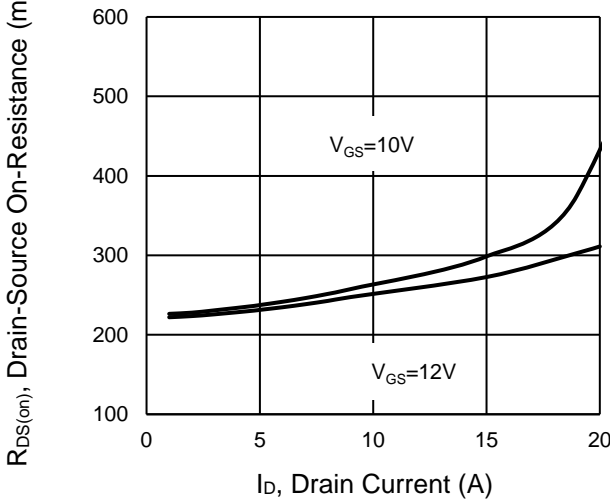

**Gate-Source Voltage vs. Gate Charge**

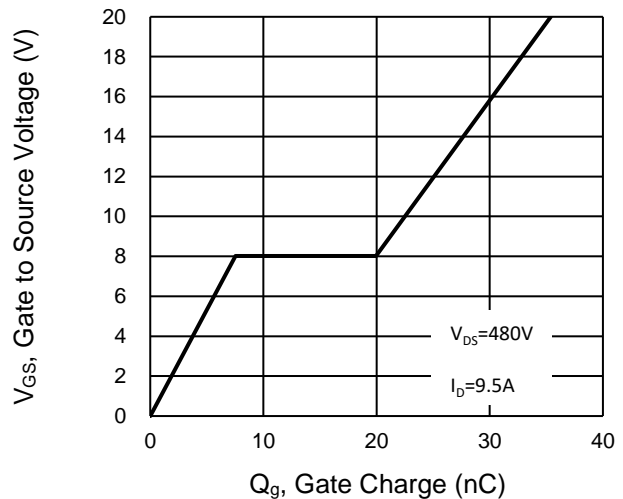

**On-Resistance vs. Junction Temperature**

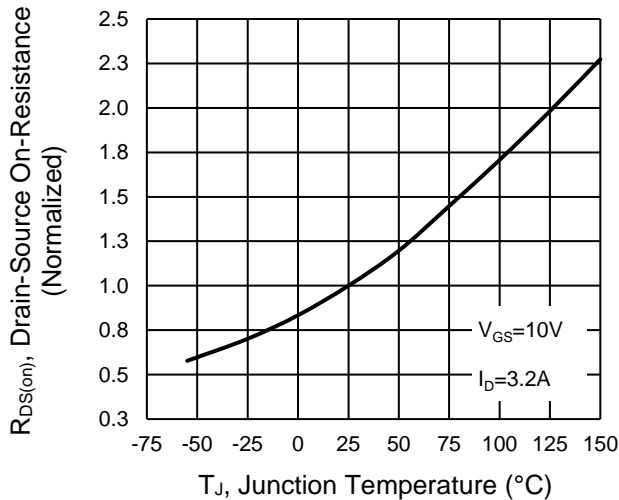

**On-Resistance vs. Gate-Source Voltage**

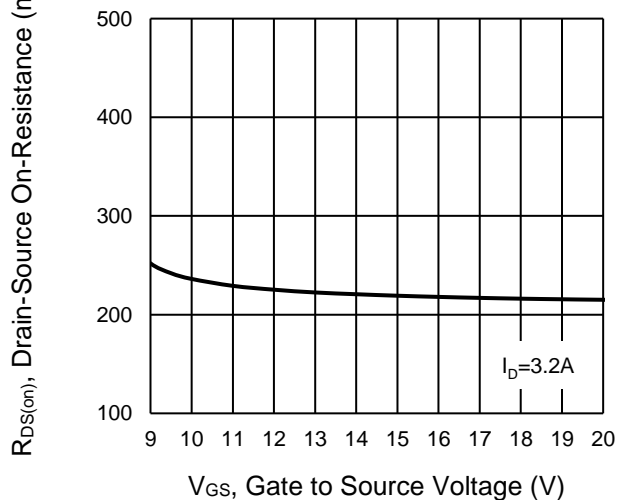

**CHARACTERISTICS CURVES**

( $T_c = 25^\circ\text{C}$  unless otherwise noted)

**Capacitance vs. Drain-Source Voltage**

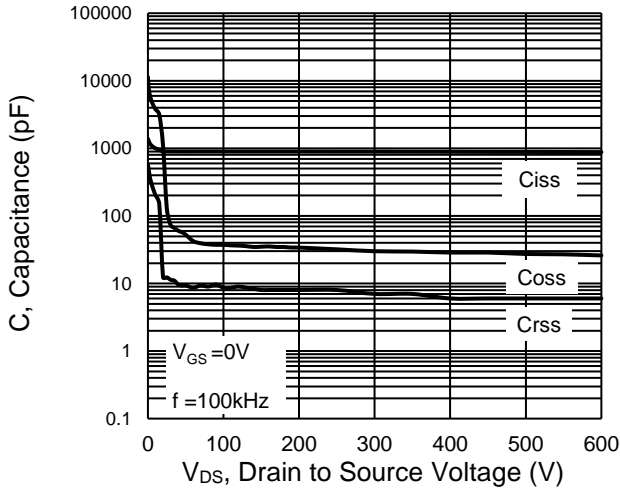

**$BV_{DSS}$  vs. Junction Temperature**

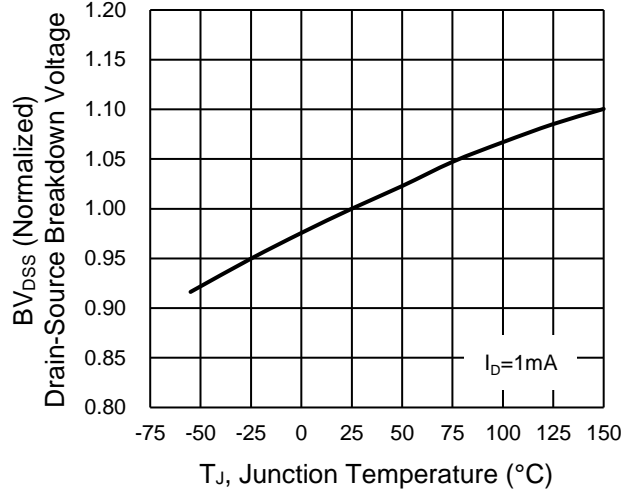

**Maximum Safe Operating Area, Junction-to-Case**

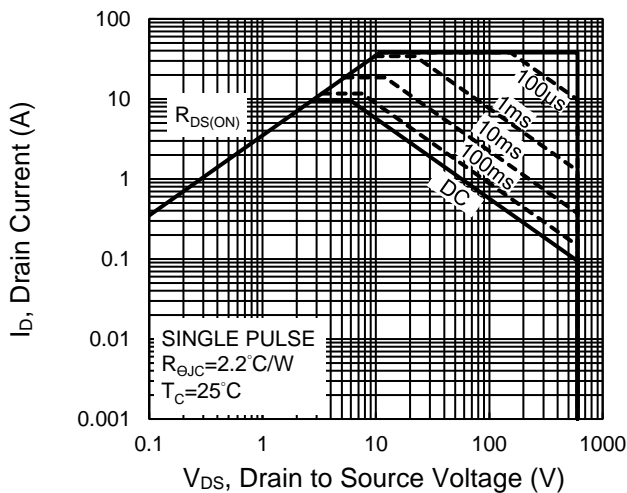

**Source-Drain Diode Forward Current vs. Voltage**

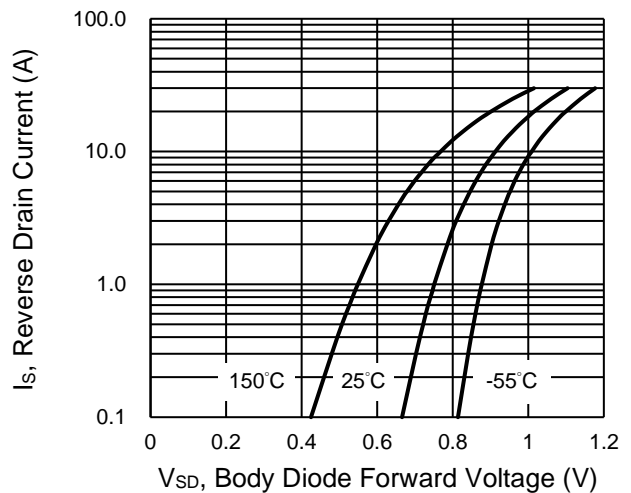

**Normalized Thermal Transient Impedance, Junction-to-Case**

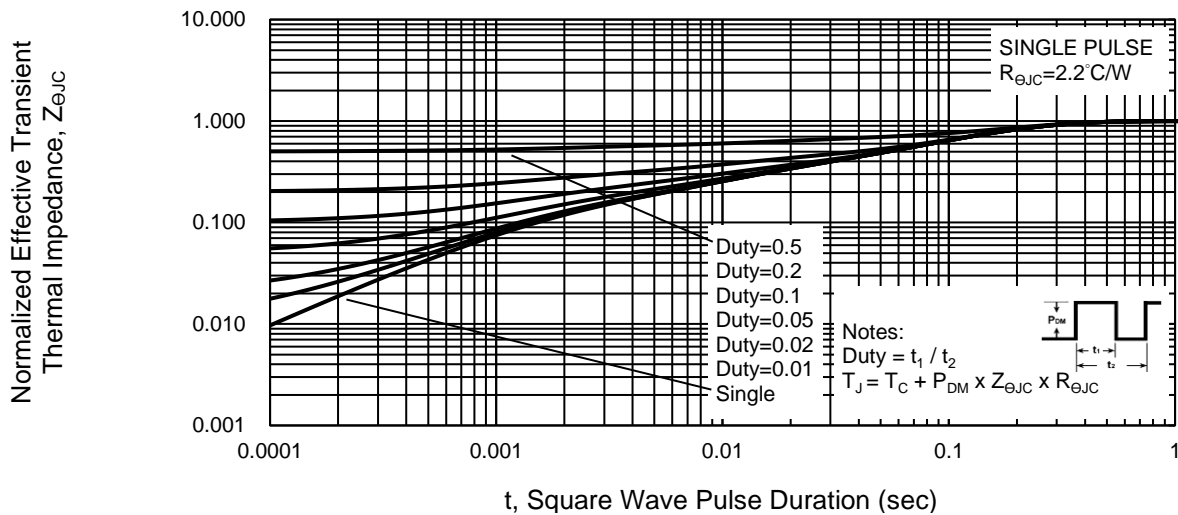

**CHARACTERISTICS CURVES**

( $T_c = 25^\circ\text{C}$  unless otherwise noted)

**Power Dissipation**

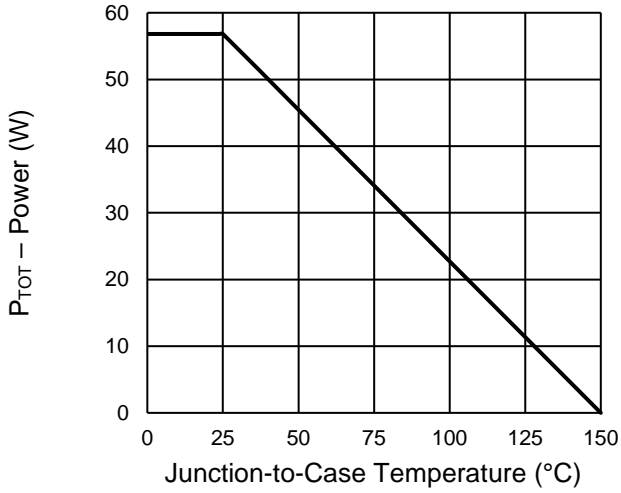

**Drain Current**

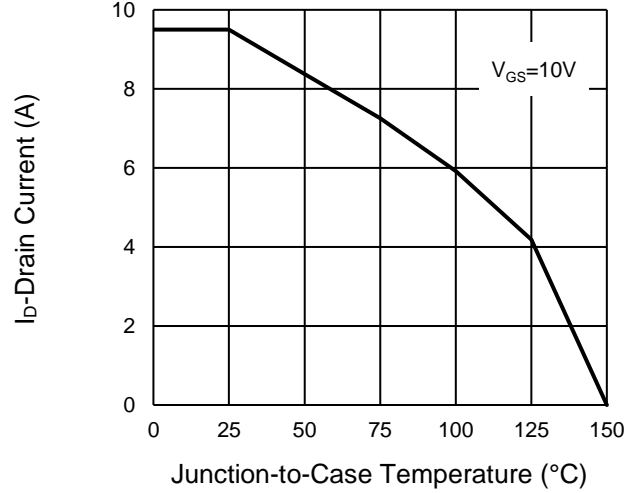

**Normalized gate threshold voltage vs Temperature**

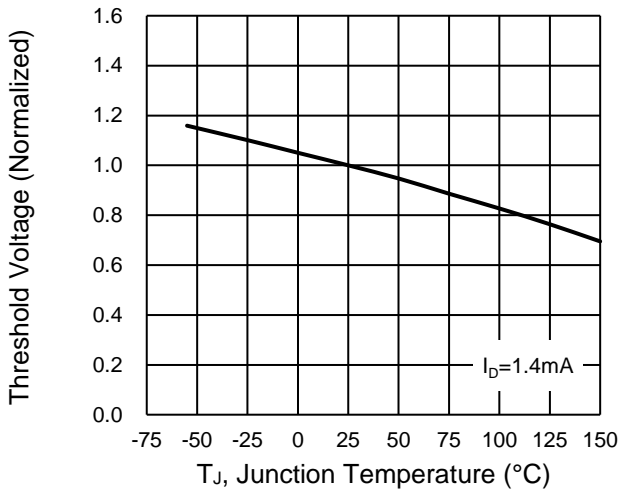

**PACKAGE OUTLINE DIMENSIONS** (Unit: Millimeters)

**ITO-220TL**

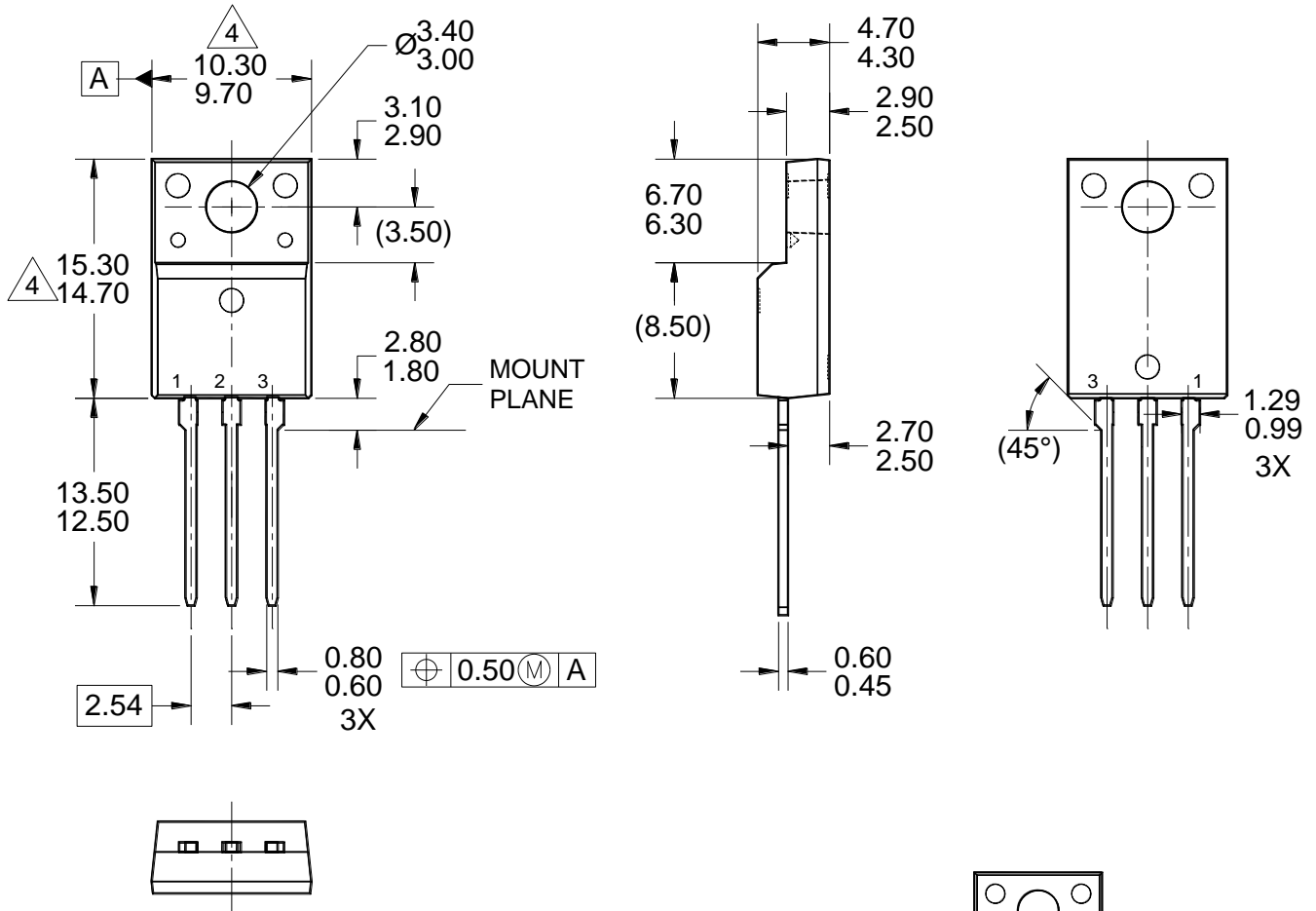

**NOTES: UNLESS OTHERWISE SPECIFIED**

1. ALL DIMENSIONS ARE IN MILLIMETERS.
2. DIMENSIONING AND TOLERANCING PER ASME Y14.5M-1994.
3. PACKAGE OUTLINE REFERENCE: EIAJ ED-7500A-1, SC-91.
4. MOLDED PLASTIC BODY DIMENSIONS DO NOT INCLUDE MOLD FLASH. THESE DIMENSIONS ARE MEASURED AT THE OUTERMOST EXTREME OF THE PLASTIC BODY.
5. DWG NO. REF: HQ2SD07-ITO220TL-016 REV B.

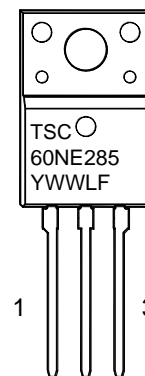

**MARKING DIAGRAM**

- |    |                       |
|----|-----------------------|
| Y  | = YEAR CODE           |
| WW | = WEEK CODE (01~52)   |
| L  | = LOT CODE (1~9, A~Z) |
| F  | = FACTORY CODE        |

## **Notice**

Specifications of the products displayed herein are subject to change without notice. TSC or anyone on its behalf, assumes no responsibility or liability for any errors or inaccuracies.

Purchasers are solely responsible for the choice, selection, and use of TSC products and TSC assumes no liability for application assistance or the design of Purchasers' products.

Information contained herein is intended to provide a product description only. No license, express or implied, to any intellectual property rights is granted by this document. Except as provided in TSC's terms and conditions of sale for such products, TSC assumes no liability whatsoever, and disclaims any express or implied warranty, relating to sale and/or use of TSC products including liability or warranties relating to fitness for a particular purpose, merchantability, or infringement of any patent, copyright, or other intellectual property right.

The products shown herein are not designed for use in medical, life-saving, or life-sustaining applications. Customers using or selling these products for use in such applications do so at their own risk and agree to fully indemnify TSC for any damages resulting from such improper use or sale.