

REAL TIME CLOCK MODULE (SPI-Bus)

Built-in 32.768 kHz-DTCXO, +105°C operating temperature,
Low current consumption, Built-in power supply switching circuit and
Time stamp function up to 32 records

RX4901CE

- Built in frequency adjusted 32.768 kHz crystal unit and DTCXO
- Interface Type : 3 wire / 4 wire SPI-Bus
- Current consumption : 240 nA / 3 V (Typ.)
- Auto power switching function : Automatically switches to backup power supply by monitoring the V_{DD} / V_{BAT} voltage
- Time stamp function : Maximum 32 time stamps
- Interrupt output : Wake up every hour or every minute or every second
- Alarm interruption : Day, date, hour, minute, second
- Auto repeat wakeup timer interruption
- Self-monitoring interruption : Crystal oscillation stop, V_{BAT} low, V_{DD} low



Product Number (2,000 pcs / Reel)
RX4901CE XS A0 : X1B000471000115
RX4901CE XB A0 : X1B000471000215
RX4901CE XS B0 : X1B000471000315
RX4901CE XB B0 : X1B000471000415
RX4901CE XS C0 : X1B000471000515
RX4901CE XB C0 : X1B000471000615
RX4901CE XS D0 : X1B000471000715
RX4901CE XB D0 : X1B000471000815

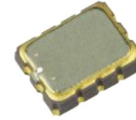

RX4901CE
(3.2 × 2.5 mm, t = 1.0 mm Max.)

Block diagram

Overview

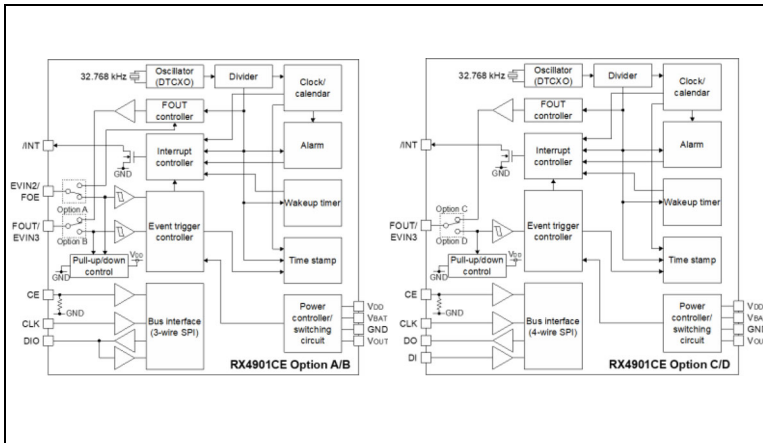

- Interface type : 3 wire / 4 wire SPI-Bus
- High stability
 XS : ±3.0 × 10⁻⁶ / -40 °C to +85 °C (Monthly rate: ±8 seconds)
 : ±5.0 × 10⁻⁶ / +85 °C to +105 °C (Monthly rate: ±13 seconds)
 XB : ±5.0 × 10⁻⁶ / -40 °C to +85 °C (Monthly rate: ±13 seconds)
 : ±8.0 × 10⁻⁶ / +85 °C to +105 °C (Monthly rate: ±21 seconds)
- Time stamp function
 Trigger source: External event (EVIN) input, voltage drop/oscillation stop status detected, command input from the host
 Record data: 1/1024 seconds to 1 second, seconds, minutes, hours, days, months, years
 Number of recordable events: Maximum 32 events
- Backup power supply switching function
 The V_{DD} and V_{BAT} voltages are monitored to switch between Normal mode (V_{DD} operation) and Backup mode (V_{BAT} operation).
- Clock output (FOUT)
 Selectable from 32.768 kHz, 1024 Hz and 1 Hz outputs
 Output can be controlled by a register or FOE input (selectable with a register).

Pin Function

Terminal connection / External dimensions (Unit: mm)

Signal Name	I / O	Function
EVIN1,2,3	Input	External event input pins. Detectable even in Backup mode. Pull-up and pull-down is configurable by the registers
CE	Input	Slave select input pin A pull-down resistor (Typ. 300 kΩ) is included
CLK	Input	Serial clock input pin
DI	Input	Serial data input pin (4 wire)
DO	Output	Serial data Output pin (4 wire)
DIO	Input / Output	Serial data input/output pin (3 wire)
FOUT	Output	Frequency output pin (CMOS). 32.768 kHz (default), 1024 Hz or 1 Hz clock output is selectable. This pin can be switched to the wakeup timer interrupt output (CMOS)
/INT	Output	Interrupt output pin (N-ch. open drain). The wakeup timer, time update, alarm, and/or event detection interrupt signals can be selected to output from this pin. When two or more signals are selected, they are NORed before being output. This pin is effective even in Backup mode.
V _{DD}	-	Power-supply pin
V _{OUT}	-	Internal operating voltage output pin Connect a 1.0 μF bypass capacitor to this pin.
V _{BAT}	-	Backup power supply pin Connect a backup power supply such as a large-size capacitor, secondary battery, or primary battery. The operating power voltage is supplied from this pin to the internal circuits in Backup mode.
GND	-	Ground pin

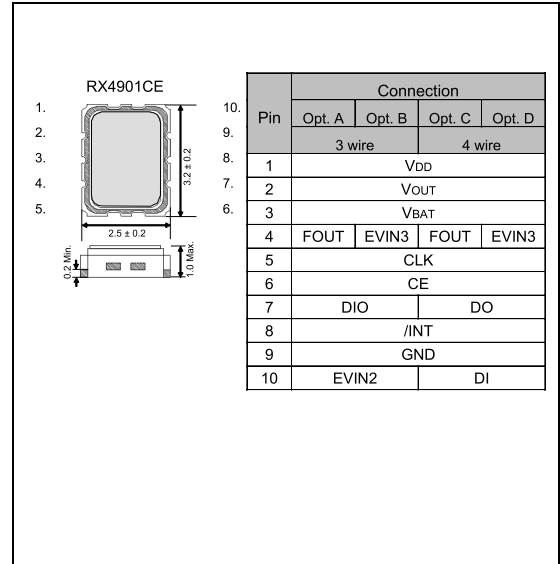

Specifications (characteristics)

* Refer to application manual for details

Recommended Operating Conditions

Item	Symbol	Condition	Min.	Typ.	Max.	unit
Operating voltage	V _{DD}	-	1.6	3.0	5.5	V
Clock supply voltage	V _{CLK}	-	1.1	3.0	5.5	V
Operating Temperature	T _a	-	-40	+25	+105	°C
V _{DD} detection voltage	-V _{DET1}	V _{DD} , Fall	1.35	1.45	1.55	V

Frequency Characteristics

Item	Symbol	Condition	Min.	Typ.	Max.	unit	
Frequency tolerance	Δf/f	XS	T _a = -40 to +85 °C	-3	-	+3	× 10 ⁻⁶
			T _a = +85 to +105 °C	-5	-	+5	
		XB	T _a = -40 to +85 °C	-5	-	+5	
			T _a = +85 to +105 °C	-8	-	+8	
start-up time	t _{STA}	T _a = +25 °C, V _{DD} = 1.6 V ~ 5.5 V	-	0.5	1.0	s	

Current consumption

Item	Symbol	Condition	T _a = -40 °C to +105 °C			
			Min.	Typ.	Max.	unit
I _{DD}	IBAT	V _{BAT} = 3.0 V, /INT= Hi-Z, FOUT: Output OFF (Hi-Z), Temperature compensation interval: 2 s, FSEL1= FSEL0 = 1, INIEN = 1, CHGEN = 0, CE = L	-	240	1500	nA
	I _{32k}	V _{DD} = 3.0 V, /INT= Hi-Z, FOUT: 32 kHz output, Cl = 0 pF, Temperature compensation interval: 2 s, FSEL1 = FSEL0 = 0, INIEN = 1, CHGEN = 0, CE = L	-	1.0	3.0	μA

Option

I/F	Option	EVIN pin Number	/INT pin Number	FOUT	Number of time stamps recorded by EVIN terminal trigger	
					FIFO Mode	Direct Mode
SPI 3 wire	A	1	1	Yes	32 times	12 times
	B	2	1	-	32 times	22 times
SPI	C	0	1	Yes	0 time	0 time
4 wire	D	1	1	-	32 times	10 times







Product name

RX4901CE XS A0
① ② ③

- ① Model CE type package 3.2 x 2.5 x 1.0 mm
- ② Frequency tolerance
 - XS: $\pm 3.0 \times 10^{-6}$ / -40 °C to +85 °C (Monthly rate: ± 8 seconds)
 - $\pm 5.0 \times 10^{-6}$ / +85 °C to +105 °C (Monthly rate: ± 13 seconds)
 - XB: $\pm 5.0 \times 10^{-6}$ / -40 °C to +85 °C (Monthly rate: ± 13 seconds)
 - $\pm 8.0 \times 10^{-6}$ / +85 °C to +105 °C (Monthly rate: ± 21 seconds)
- ③ Pin Option
 - A: Option A
 - B: Option B
 - C: Option C
 - D: Option D

► Explanation of the mark that are using it for the catalog

	<p>► Pb free.</p>
	<p>► Complies with EU RoHS directive. *About the products without the Pb-free mark. Contains Pb in products exempted by EU RoHS directive. (Contains Pb in sealing glass, high melting temperature type solder or other.)</p>
	<p>► Designed for automotive general equipment.</p>
	<p>► Designed for automotive applications related to driving and safety.</p>

NOTICE : PLEASE READ CAREFULLY BELOW BEFORE THE USE OF THIS DOCUMENT

- The content of this document is subject to change without notice. Before purchasing or using Epson products, please contact with sales representative of Seiko Epson Corporation ("Epson") for the latest information and be always sure to check the latest information published on Epson's official web sites and resources.
- This document may not be copied, reproduced, or used for any other purposes, in whole or in part, without Epson's prior consent.
- Information provided in this document including, but not limited to application circuits, programs and usage, is for reference purpose only. Epson makes no guarantees against any infringements or damages to any third parties' intellectual property rights or any other rights resulting from the information. This document does not grant you any licenses, any intellectual property rights or any other rights with respect to Epson products owned by Epson or any third parties.
- Epson has prepared this document carefully to be accurate and dependable, but Epson does not guarantee that the information is always accurate and complete. Epson assumes no responsibility for any damages you incurred due to any misinformation in this document.
- Epson products listed in this document and our associated technologies shall not be used in any equipment or systems that laws and regulations in Japan or any other countries prohibit to manufacture, use or sell. Furthermore, Epson products and our associated technologies shall not be used for the purposes of military weapons development (e.g. mass destruction weapons), military use, or any other military applications. If exporting Epson products or our associated technologies, please be sure to comply with the Foreign Exchange and Foreign Trade Control Act in Japan, Export Administration Regulations in the U.S.A (EAR) and other export-related laws and regulations in Japan and any other countries and to follow their required procedures.
- Epson assumes no responsibility for any damages (whether direct or indirect) caused by or in relation with your non-compliance with the terms and conditions in this document or for any damages (whether direct or indirect) incurred by any third party that you give, transfer or assign Epson products.
- For more details or other concerns about this document, please contact our sales representative.
- Company names and product names listed in this document are trademarks or registered trademarks of their respective companies.

●Disclaimer

- Epson products are designed for use in general electronic equipment applications that do not require extremely high reliability or safety.
- Epson does not represent or warrant that its products will not cause a failure for any particular application, except for cases where the failure is a direct result caused by defects in materials and workmanship of this product.
 If a product fails due to defects in materials and workmanship, to the maximum extent permitted by law, we will, at our sole discretion, refund or replace the affected product.
- When products for used directly or indirectly in certain devices or applications (ex. Nuclear power, aerospace, infrastructure facilities, medical equipment, etc.) which are connected to or affect safety of human life or property, Customer is solely responsible for determining if the products and respective specifications are suitable for the intended use in particular customer applications.
 Customer shall implement necessary and proper safety design and measures (including redundant design, malfunction prevention design, etc.) to ensure reliability and safety before using the products in/with customer's Equipment.
- For the products designed for automotive applications, the products comply with AEC-Q100 or AEC-Q200.
 Products do not comply with ISO 26262 (Products are not categorized to ASIL A, B, C and D).
- No dismantling, analysis, reverse engineering, modification, alteration, adaptation, reproduction, etc., of Epson products is allowed.
 Furthermore, any defects caused by this are not covered by the warranty.

©Seiko Epson Corporation 2025